

# People's Physics Book - CK12 - \*

DRAFT

**CK12 Foundation**

**flexbook**  
*next generation textbooks*

CK-12 is a non-profit organization dedicated to the objective that every K-12 student in the United States and worldwide deserves access to the highest-quality and lowest-cost textbooks and course materials. By using open educational resources in a collaborative, web-based compilation model that we call the "FlexBook," CK-12 enables the educational community to author, enhance, and publish these course materials to suit specific needs and environments.

[www.ck12.org](http://www.ck12.org)

*People's Physics Book - CK12 - \**  
Copyright 2008  
Some rights reserved.  
\* For Review

**flexbook**  
next generation textbooks



This material is licensed under the Creative Commons Attribution-Share Alike license (<http://creativecommons.org/licenses/by-sa/3.0/>).

Print date: 2009-01-29 12:49  
CK12 psn: fd695eb8138bcacb4f0c1746fd9a197d

# Contents

1. Introduction and Vision.....	4
2. Units and Problem Solving.....	7
3. Energy Conservation.....	12
4. One-Dimensional Motion.....	16
5. Two-Dimensional and Projectile Motion.....	24
6. Newton's Laws.....	30
7. Centripetal Forces.....	43
8. Momentum Conservation.....	49
9. Energy and Force.....	57
10. Rotational Motion.....	66
11. Simple Harmonic Motion.....	74
12. Wave Motion and Sound.....	79
13. Electricity.....	87
14. Electric Circuits: Batteries and Resistors.....	94
15. Magnetism.....	103
16. Electric Circuits:Capacitors.....	110
17. Electric Circuits Advanced Topics.....	114
18. Light.....	119
19. Fluids.....	131
20. Thermodynamics and Heat Engines.....	137
21. Radioactivity and Nuclear Physics.....	144
22. Standard Model of Particle Physics.....	150
23. Feynman's Diagrams.....	154
24. Quantum Mechanics.....	160
25. Physics with Calculus.....	167
26. The Physics of Global Warming.....	171
27. Answers to Selected Problems.....	181
28. Equations and Fundamental Constants.....	194

# 1. Introduction and Vision

AUTHOR: James H. Dann, Ph.D., James J. Dann SOURCE: The People's Physics Book LICENSE: CCSA

## The People's Physics Book

### *Authors*

James H. Dann, Ph.D.

James J. Dann

### *Illustrator*

Jason P. Murphy

### *Contributors and Consultants*

Byron J Philhour

Kimberly M. Knestrick

Mark J. Abruzzese

## Textbook Website

<http://scipp.ucsc.edu/outreach/index2.html>

“Each discovery, each advance, each increase in the sum of human riches, owes its being to the physical and mental travail of the past and the present. By what right then, can any one whatever appropriate the least morsel of this immense whole and say – This is mine, not yours?”

– Peter Kropotkin (1842 – 1921)

“Wisdom is not a product of schooling, but of the life-long attempt to acquire it.”

– Albert Einstein (1879 – 1955)

“To think out a problem is not unlike drawing a caricature. You have to exaggerate the salient point and leave out that which is not typical.”

– Eric Hoffer (1902 – 1983)

Dedication of the book is to two physicists who gave us particular inspiration. Their contributions to experimental and theoretical physics are all the more remarkable given that they worked as Jews in the Germany and Italy of the 1930's:

1. Bruno Rossi, author of *Optics* and *Momenti Nella Vita di uno Scienziato*.



2. Adolph Dannenbaum, author of *Die Dampfmaschine und ihre Steuerung* (text on thermodynamics).

JHD would like to dedicate this book to Aaron, Nisha, and Ashaan. Special thanks goes to Laurel Reitman for fruitful discussions and Keith Mansfield for fruitful discussions and lunch.

The authors would like to thank all the honors and AP Physics students at Natomas High School in Sacramento and St. Ignatius in San Francisco in the years 2000-2005 for trying out all the early versions of the big ideas, key concepts, and many of the problems.

We also thank our fellow physics teachers at both schools for their immense help and contributions.

### The Big Idea

The intent of the authors is to produce an inexpensive alternative textbook for high school and college physics students and teachers. Our vision is of a physics teacher cooperative that produces excellent work at little or no cost to the students.

### How to Use This Textbook

This textbook is intended to be used as one small part of a multifaceted strategy to teach physics conceptually and mathematically. It is intended as a reference guide and problem text that students can carry to and from class with ease. Some students will need a more in-depth textbook for reading and sample problems: for this we suggest an in-class library that includes standard texts as well as current science magazines and articles. The textbook assumes a thorough knowledge of the subjects usually covered in Algebra II classes, including right triangle trigonometry and vector addition and components. Some previous familiarity with physical science or chemistry is assumed, including use of the periodic table, the mole and significant digits. And, of course, this textbook does not attempt to replace the important work that students and teachers do together, in the classroom.

### AP Physics Exams

We think this book will be especially helpful for students preparing for the **AP Physics B** test. All material currently tested is in this book. Students planning to take the test should cover all chapters prior to the test except chapters 16, 20, 21, 22, and 23. Those chapters can be left for after the test or as enrichment. Also it is recommended that Chapters 9 and 15 be covered lightly since these topics are not tested in the detail that our book covers them.

For the **AP Physics C (mechanics)** test the book is also an excellent preparation. Chapters 1-10 and 25 need be covered thoroughly. For the AP physics C (electromagnetism) test the book is not sufficient; it can be used however, for some basic concepts and provide practice in solving circuits. (Use Chapters 12-16.)

### California State Content Standards for Physics

Physics Concepts	California Standard	Chapter(s) in People's Physics Book
Kinematics	1 a	3
Newton's Laws	1 b, c, d	5
Universal gravitation and centripetal motion	1 e, f, g, l	6
Relativistic and quantum effects	1 h	20, 24
Two dimensional trajectories	1 i, j	4
Statics	1 k, m	6, 12
Conservation of energy	2 a, b, c	2
Conservation of momentum	2 d, e, f	7

Energy and momentum	<b>2 g</b>	<b>8</b>
Springs and capacitors	<b>2 h</b>	<b>10. 15</b>
Heat and thermodynamics	<b>3 a, b, c, d, e, f, g</b>	<b>19</b>
Waves and harmonic motion	<b>4 a, b, c, d</b>	<b>11</b>
Light waves	<b>4 e</b>	<b>17</b>
Characteristics of Waves	<b>4 f</b>	<b>11. 17</b>
Electric Circuits	<b>5 a, b, c</b>	<b>13</b>
Transistors	<b>5 d</b>	<b>16</b>
Magnetism	<b>5 f, g, h, j, n</b>	<b>14</b>
Electric Forces and Fields	<b>5 e, k, l, m, o</b>	<b>12</b>

DRAFT

## 2. Units and Problem Solving

AUTHOR: James H. Dann, Ph.D., James J. Dann SOURCE: The People's Physics Book LICENSE: CCSA



### The Big Idea

Units identify what a specific number represents. For example, the number 42 can be used to represent 42 miles, 42 pounds, or 42 elephants! Without the units attached, the number is meaningless. Also, correct unit cancellation can help you find mistakes when you work out problems.

### Key Concepts

- Every answer to a physics problem must include units. Even if a problem explicitly asks for a speed in meters per second (m/s), the answer is 5 m/s, not 5.
- When you're not sure how to attack a problem, you can often find the appropriate equation by thinking about which equation will provide an answer with the correct units. For instance, if you are looking to predict or calculate a distance, use the equation where all the units cancel out, with only a unit of distance remaining.
- This textbook uses *SI units* (La Syst me International d'Unit s).
- When converting speeds from one set of units to another, remember the following rule of thumb: a speed measured in *mi/hr* is about double the value measured in *m/s* (i.e., 10 m/s is equal to about 20 MPH). Remember that the speed itself hasn't changed, just our representation of the speed in a certain set of units.
- If a unit is named after a person, it is capitalized. So you write "10 Newtons," or "10 N," but "10 meters," or "10 m."
- Vectors are arrows that represent quantities with direction. In this textbook, vectors will be written in bold. For instance, the force vector will be written as **F** in this textbook. Your teacher will likely use

$\vec{F}$

to represent vectors. Don't let this confuse you:

$\vec{F}$

represents the same concept as **F**.

- Vectors can be added together in a simple way. Two vectors can be moved (without changing their directions) to become two legs of a parallelogram. The sum of two vectors is simply the diagonal of the parallelogram:



### Key Equations

1 meter = 3.28 feet	
1 mile = 1.61 kilometers	1 lb. (1 pound) = 4.45 Newtons

### Key Applications

The late, great physicist Enrico Fermi used to solve problems by making educated guesses. For instance, say you want to *guesstimate* the number of cans of soda drunk by everybody in San Francisco in one year. You'll come pretty close if you guess that there are about 800,000 people in S.F., and that each person drinks on average about 100 cans per year. So, 80,000,000 cans are consumed every year. Sure, this answer is wrong, but it is likely not off by more than a factor of 10 (i.e., an "order of magnitude"). That is, even if we guess, we're going to be in the *ballpark* of the right answer. That is always the first step in working out a physics problem.

Type of measurement	Commonly used symbols	Fundamental units
length or position	d, x, L	meters (m)
time	t	seconds (s)
velocity or speed	v, u	meters per second (m/s)
mass	m	kilograms (kg)
force	<b>F</b>	Newtons (N)
energy	E, K, U, Q	Joules (J)
power	P	Watts (W)
electric charge	q, e	Coulombs (C)
temperature	T	Kelvin (K)
electric current	I	Amperes (A)
electric field	<b>E</b>	Newtons per Coulomb (N/C)
magnetic field	<b>B</b>	Tesla (T)
magnetic flux	$\Phi$	Webers (Wb)

### Pronunciation table for commonly used Greek letters

$\mu$ "mu"	$\tau$ "tau"	$\Phi$ "phi"	$\omega$ "omega"	$\rho$ "rho"
$\theta$ "theta"	$\pi$ "pi"	$\Omega$ "omega"	$\lambda$ "lambda"	$\Sigma$ "sigma"
$\alpha$ "alpha"	$\beta$ "beta"	$\gamma$ "gamma"	$\Delta$ "delta"	$\epsilon$ "epsilon"

\* upper case (a subscript zero, such as that found in “ $x_0$ ” is often pronounced “naught” or “not”)

### Units and Problem Solving Problem Set

1. Estimate or measure your height.
  - a. Convert your height from feet and inches to meters.
  - b. Convert your height from feet and inches to centimeters ( $100 \text{ cm} = 1 \text{ m}$ )
2. Estimate or measure the amount of time that passes between breaths when you are sitting at rest.
  - a. Convert the time from seconds into hours
  - b. Convert the time from seconds into milliseconds (ms)
3. Convert the French speed limit of  $140 \text{ km/hr}$  into  $\text{mi/hr}$ .
4. Estimate or measure your weight.
  - a. Convert your weight in pounds into a mass in kg
  - b. Convert your mass from kg into  $\mu\text{g}$
  - c. Convert your weight into Newtons
5. Find the *SI* unit for pressure.
6. An English lord says he weighs 12 stone.
  - a. Convert his weight into pounds (you may have to do some research online)
  - b. Convert his weight in stones into a mass in kilograms
7. If the speed of your car increases by  $10 \text{ mi/hr}$  every 2 seconds, how many  $\text{mi/hr}$  is the speed increasing every second? State your answer with the units  $\text{mi/hr/s}$ .
8. A tortoise travels 15 meters (m) west, then another 13 centimeters (cm) west. How many meters total has she walked?



9. A tortoise, Bernard, starting at point A travels 12 m west and then 150 millimeters (mm) east. How far west of point A is Bernard after completing these two motions?
10.  $80 \text{ m} + 145 \text{ cm} + 7850 \text{ mm} = X \text{ mm}$ . What is  $X$ ?
11. A square has sides of length 45 mm. What is the area of the square in  $\text{mm}^2$ ?
12. A square with area  $49 \text{ cm}^2$  is stretched so that each side is now twice as long. What is the area of the square now? Include a sketch.

13. A rectangular solid has a square face with sides 5 cm in length, and a length of 10 cm. What is the volume of the solid in  $\text{cm}^3$ ? Sketch the object, including the dimensions in your sketch.
14. As you know, a cube with each side 4 m in length has a volume of  $64 \text{ m}^3$ . Each side of the cube is now doubled in length. What is the *ratio* of the new volume to the old volume? Why is this ratio **not** simply 2? Include a sketch with dimensions.
15. What is the ratio of the mass of the Earth to the mass of a single proton? (See equation sheet.)
16. A spacecraft can travel 20 km/s. How many km can this spacecraft travel in 1 hour (h)?
17. A dump truck unloads 30 kilograms (kg) of garbage in 40 s. How many kg/s are being unloaded?
18. The lengths of the sides of a cube are doubling each second. At what rate is the volume increasing?
19. Estimate the number of visitors to Golden Gate Park in San Francisco in one year. Do your best to get an answer that is correct within a factor of 10.
20. Estimate the number of water drops that fall on San Francisco during a typical rainstorm.
21. What does the formula  $\mathbf{a} = \mathbf{F} / m$  tell you about the units of the quantity  $\mathbf{a}$  (whatever it is)?
22. Add the following vectors using the parallelogram method.

a.



b.

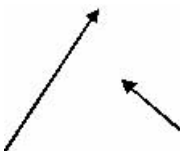

c.

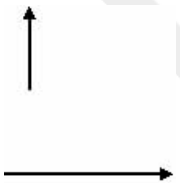

d.



e.

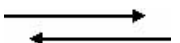

f. For adding more than two vectors, simply add any two then add the third. Order is not important.



DRAFT

# 3. Energy Conservation

AUTHOR: James H. Dann, Ph.D., James J. Dann SOURCE: The People's Physics Book LICENSE: CCSA



## The Big Idea

Energy is a measure of the amount of, or potential for, dynamical activity in something. The total amount of energy in the universe is always the same. This symmetry is called a conservation law. Physicists have identified five conservation laws that govern our universe.

A group of things (we'll use the word *system*) has a certain amount of energy. Energy can be added to a system; for instance, when chemical bonds in a burning log break, they release heat. Energy can be lost from a system; for instance, when a spacecraft “burns up” its energy of motion during re-entry, it loses energy and the surrounding atmosphere gains the lost energy. A *closed* system is one for which the energy is constant, or *conserved*. In this chapter, we will often consider closed systems, for which the total amount of energy stays the same, but transforms from one kind to another. We will consider transfers of energy between systems – known as *work* – in more detail in Chapter 8.

Key Definitions	Key Equations	
$m$ = mass (in kilograms, kg)	$K = \frac{1}{2} mv^2$	Kinetic energy
$h$ = height above the ground (in meters, m)		
$v$ = speed (in meters per second, m/s)	$U_g = mgh$	Gravitational potential energy
$g$ = acceleration due to gravity ( $9.8 \text{ m/s}^2$ )		
$E$ = energy (in Joules; $1 \text{ J} = 1 \text{ kg}\cdot\text{m}^2/\text{s}^2$ )		

## Key Concepts

- The energy of motion is kinetic energy,  $K$ . Whenever an object is in motion it has kinetic energy. The faster it is going, the more energy it has.
- The energy due to gravity is called gravitational potential energy,  $U_g$ , which gets higher the farther off the ground you are.



- Molecules have chemical potential energy due to the bonds between the electrons; when these bonds are broken, energy is released which can be transferred into kinetic and/or potential energy. 1 food Calorie is equal to 4180 Joules of stored chemical potential energy.
- Energy can be transformed from one kind into the other; if the total energy at the end of the process appears to be less than at the beginning, the “lost” energy has been transferred to another system, often by heat or sound waves.

### Key Applications

- In “roller coaster” problems, the gravitational potential energy at the top of one hill turns into kinetic energy at the next valley. It turns back into potential energy as you round the next hill, and so on. However, in reality a fraction of the energy is lost to the tracks and air as heat, which is why the second rise is often not as big as the first in amusement parks.
- In “pole-vaulter” problems, the athlete’s body breaks down the food molecules to change some of the bonding energy into energy that is used to power the body. This energy goes on to turn into kinetic energy as the athlete gains speed. The kinetic energy can be changed into potential energy as the athlete gains height.
- In “pendulum” problems, the potential energy at the highest point in a pendulum’s swing changes to kinetic energy when it reaches the bottom and then back into potential energy when it reaches the top again. At any in-between point there is a combination of kinetic energy and potential energy, but the total energy remains the same.

### Energy Conservation Problem Set

1. A stationary bomb explodes into hundreds of pieces. Which of the following statements best describes the situation?

- The kinetic energy of the bomb was converted into heat.
- The chemical potential energy stored in the bomb was converted into heat and gravitational potential energy.
- The chemical potential energy stored in the bomb was converted into heat and kinetic energy.
- The chemical potential energy stored in the bomb was converted into heat, sound, kinetic energy, and gravitational potential energy.
- The kinetic and chemical potential energy stored in the bomb was converted into heat, sound, kinetic energy, and gravitational potential energy.

2. You hike up to the top of Granite Peak in the Trinity Alps to think about physics.

- Do you have more potential or kinetic energy at the top of the mountain than you did at the bottom? Explain.
- Do you have more, less, or the same amount of energy at the top of the mountain than when you started? (Let’s assume you did not eat anything on the way up.) Explain.
- How has the total energy of the Solar System changed due to your hike up the mountain? Explain.
- If you push a rock off the top, will it end up with more, less, or the same amount of energy at the bottom? Explain.
- For each of the following types of energy, describe whether you *gained* it, you *lost* it, or it stayed the same during your hike:
  - Gravitational potential energy

- ii. Energy stored in the atomic nuclei in your body
- iii. Heat energy
- iv. Chemical potential energy stored in the fat cells in your body
- v. Sound energy from your footsteps
- vi. Energy given to you by a wind blowing at your back

3. Just before your mountain bike ride, you eat a 240 Calorie exercise bar. (You can find the conversion between food Calories and Joules in the chapter.) The carbon bonds in the food are broken down in your stomach, releasing energy. About half of this energy is lost due to inefficiencies in your digestive system.

a. Given the losses in your digestive system how much of the energy, in Joules, can you use from the exercise bar?

After eating, you climb a 500 m hill on your bike. The combined mass of you and your bike is 75kg.

b. How much gravitational potential energy has been gained by you and your bike?

c. Where did this energy come from?

d. If you ride quickly down the mountain without braking but losing half the energy to air resistance, how fast are you going when you get to the bottom?

4. You find yourself on your bike at the top of Twin Peaks in San Francisco. You are facing a 600m descent. The combined mass of you and your bicycle is 85 kg.

a. How much gravitational potential energy do you have before your descent?

b. You descend. If all that potential energy is converted to kinetic energy, what will your speed be at the bottom?

c. Name two other places to which your potential energy of gravity was transferred besides kinetic energy. How will this manifest itself in your speed at the bottom of the hill? (No numerical answer is needed here.)



5. Before a run, you eat an apple with 1,000,000 Joules of binding energy.

a. 550,000 Joules of binding energy are wasted during digestion. How much remains?

b. Some 95% of the remaining energy is used for the basic processes in your body (which is why you can warm a bed at night!). How much is available for running?

c. Let's say that, when you run, you lose 25% of your energy overcoming friction and air resistance. How much is available for conversion to kinetic energy?

d. Let's say your mass is 75 kg. What could be your top speed under these idealized circumstances?

e. But only 10% of the available energy goes to KE, another 50% goes into heat exhaust from your body. Now you come upon a hill if the remaining energy is converted to gravitational potential energy. How high do you climb before running out of energy completely?

6. A car goes from rest to a speed of  $v$  in a time  $t$ . Sketch a schematic graph of kinetic energy vs. time. You do not need to label the axes with numbers.

7. A 1200 kg car traveling with a speed of 29 m/s drives horizontally off of a 90 m cliff.

a. Sketch the situation.

b. Calculate the potential energy, the kinetic energy, and the total energy of the car as it leaves the cliff.

c. Make a graph displaying the kinetic, gravitational potential, and total energy of the car at each 10m increment of height as it drops

8. A roller coaster begins at rest 120 m above the ground at point A, as shown above. Assume no energy is lost from the coaster to frictional heating, air resistance, sound, or any other process. The radius of the loop is 40 m.

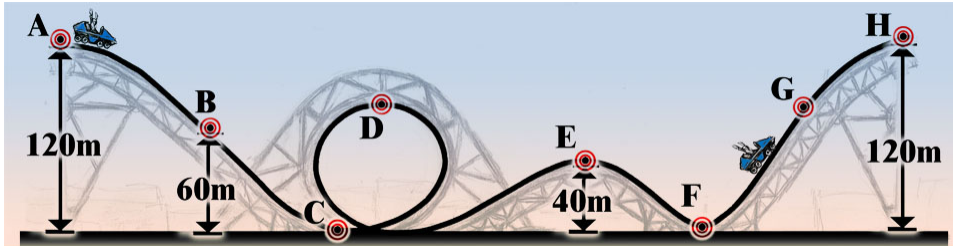

a. Find the speed of the roller coaster at points B, C, D, E, F, and H.

b. At point G the speed of the roller coaster is 22 m/s. How high off the ground is point G?

9. A pendulum has a string with length 1.2 m. You hold it at an angle of 22 degrees to the vertical and release it. The pendulum bob has a mass of 2.0 kg.

a. What is the potential energy of the bob before it is released? (*Hint: use geometry to determine the height when released.*)

b. What is its speed when it passes through the midpoint of its swing?

c. Now the pendulum is transported to Mars, where the acceleration of gravity  $g$  is  $2.3 \text{ m/s}^2$ . Answer parts (a) and (b) again, but this time using the acceleration on Mars.

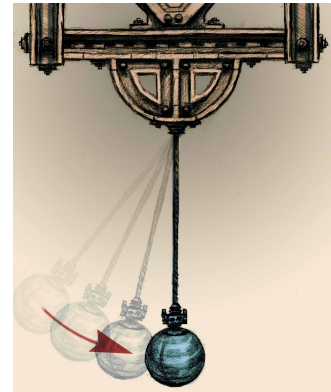

10. On an unknown airless planet an astronaut drops a 4.0 kg ball from a 60 m ledge. The mass hits the bottom with a speed of 12 m/s.

a. What is the acceleration of gravity  $g$  on this planet?

b. The planet has a twin moon with exactly the same acceleration of gravity. The difference is that this moon has an atmosphere. In this case, when dropped from a ledge with the same height, the 4.0 kg ball hits bottom at the speed of 9 m/s. How much energy is lost to air resistance during the fall?

11. A 1500 kg car starts at rest and speeds up to 3.0 m/s.

a. What is the gain in kinetic energy?

b. We define efficiency as the ratio of output energy (in this case kinetic energy) to input energy. If this car's efficiency is 0.30, how much input energy was provided by the gasoline?

c. If 0.15 gallons were used up in the process, what is the energy content of the gasoline in Joules per gallon?

12. A pile driver's motor expends 310,000 Joules of energy to lift a 5400 kg mass. The motor is rated at an efficiency of 0.13 (see 11b). How high is the mass lifted?

## 4. One-Dimensional Motion

AUTHOR: James H. Dann, Ph.D., James J. Dann SOURCE: The People's Physics Book LICENSE: CCSA



### The Big Idea

Speed represents how quickly an object is moving through space. Velocity is speed with a direction, making it a *vector* quantity. If an object's velocity changes with time, the object is said to be accelerating. As we'll see in the next chapters, understanding the acceleration of an object is the key to understanding its motion.

### Key Definitions

#### Vectors

$\mathbf{x} = \mathbf{x}(t)$  = position (m)

$\Delta\mathbf{x}$  = displacement =  $\mathbf{x}_f - \mathbf{x}_i$

$\mathbf{v} = \mathbf{v}(t)$  = velocity (m/s)

$\mathbf{v}_0$  = initial velocity

$\mathbf{v}_f$  = final velocity

$\Delta\mathbf{v}$  = change in velocity =  $\mathbf{v}_f - \mathbf{v}_i$

$\mathbf{a}$  = instantaneous acceleration (m/s<sup>2</sup>)

#### Scalars

$t$  = time (s)

$d$  = distance (m) =  $|\Delta\mathbf{x}_1| + |\Delta\mathbf{x}_2| + \dots$

$v$  = speed (m/s) =  $|\mathbf{v}|$

#### Symbols

$\Delta(\text{anything})$  = final value – initial value

$(\text{anything})_0$  = value of that quantity at time  $t = 0$

### Key Equations

	<i>The "Big Three"</i>
$\mathbf{v}_{\text{avg}} = \Delta\mathbf{x}/\Delta t$	$x(t) = x_0 + v_0t + \frac{1}{2}at^2$
$\mathbf{a}_{\text{avg}} = \Delta\mathbf{v}/\Delta t$	$v(t) = v_0 + at$
	$v^2 = v_0^2 + 2a(\Delta x)$

### Key Concepts

- When you begin a problem, define a positive (+ $x$ ) direction and negative ( $-x$ ) direction. For instance the positive direction can be “towards the right” and the negative direction “towards the left.” Use these directions consistently with velocity  $v$  and acceleration  $a$ .
- Be sure you understand the difference between average velocity (measured over a long period of time) and instantaneous velocity (measured at a single moment in time).
- Gravity near the Earth pulls an object downwards toward the surface of the Earth with an acceleration of  $9.8 \text{ m/s}^2$  ( $\approx 10 \text{ m/s}^2$ ). In the absence of air resistance, all objects will fall with the same acceleration. Air resistance can cause low-mass, large area objects to accelerate more slowly.
- *Deceleration* is the term used when an object's *speed* is decreasing due to an acceleration in the opposite direction of its velocity.
- The Big Three equations allow you to draw the position and velocity of something as a function of time. This is a nice way to visualize motion. When there is acceleration,  $x(t)$  produces a parabola in  $t$ , while  $v(t)$  produces a straight line in  $t$ . The slope of a  $x(t)$  graph equals the instantaneous velocity. The slope of a  $v(t)$  graph equals the acceleration.
- At first, you might get frustrated trying to figure out which of the Big Three equations to use for a certain problem, but don't worry, this comes with practice. Making a table that identifies the variables given in the problem and the variables you are looking for can sometimes help.

### One-Dimensional Motion Problem Set

1. Answer the following questions about one-dimensional motion.

- What is the difference between distance  $d$  and displacement  $\Delta x$ ? Write a few sentences explaining this.
- Does the odometer reading in a car measure distance or displacement?
- Imagine a fox darting around in the woods for several hours. Can the displacement  $\Delta x$  of the fox from his initial position ever be larger than the total distance  $d$  he traveled? Explain.
- What is the difference between acceleration and velocity? Write a paragraph that would make sense to a 5<sup>th</sup> grader.
- Give an example of a situation where an object has an upward velocity, but a downward acceleration.
- What is the difference between average and instantaneous velocity? Make up an example involving a trip in a car that demonstrates your point.
- If the position of an object is increasing linearly with time (i.e.,  $\Delta x$  is proportional to  $t$ ), what can we say about its acceleration? Explain your thinking.
- If the position of an object is increasing non-linearly with time (i.e.,  $\Delta x$  is not proportional to  $t$ ), what can we say about its velocity? Explain your thinking.

2. A cop passes you on the highway. Which of the following statements must be true at the instant he is passing you? You may choose more than one answer.

- Your speed and his speed are the same.
- Your position  $x$  along the highway is the same as his position  $x$  along the highway.
- Your acceleration and his acceleration are the same.

3. If a car is slowing down from 50 MPH to 40 MPH, but the  $x$  position is increasing, which of the following statements is true? You may choose more than one.

- a. The velocity of the car is in the  $+x$  direction.
- b. The acceleration of the car is in the same direction as the velocity.
- c. The acceleration of the car is in the opposite direction of the velocity.
- d. The acceleration of the car is in the  $-x$  direction.

4. A horse is galloping forward with an acceleration of  $3 \text{ m/s}^2$ . Which of the following statements is necessarily true? You may choose more than one.

- a. The horse is increasing its speed by  $3 \text{ m/s}$  every second, from  $0 \text{ m/s}$  to  $3 \text{ m/s}$  to  $6 \text{ m/s}$  to  $9 \text{ m/s}$ .
- b. The speed of the horse will triple every second, from  $0 \text{ m/s}$  to  $3 \text{ m/s}$  to  $9 \text{ m/s}$  to  $27 \text{ m/s}$ .
- c. Starting from rest, the horse will cover  $3 \text{ m}$  of ground in the first second.
- d. Starting from rest, the horse will cover  $1.5 \text{ m}$  of ground in the first second.

5. Below are images from a race between Ashaan (above) and Zyan (below), two daring racecar drivers. High speed cameras took four pictures in rapid succession. The first picture shows the positions of the cars at  $t = 0.0$ . Each car image to the right represents times  $0.1$ ,  $0.2$ , and  $0.3$  seconds later.

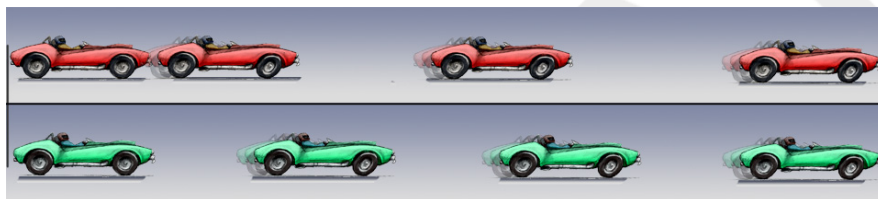

- a. Who is ahead at  $t = 0.2 \text{ s}$ ? Explain.
- b. Who is accelerating? Explain.
- c. Who is going fastest at  $t = 0.3 \text{ s}$ ? Explain.
- d. Which car has a constant velocity throughout? Explain.
- e. Graph  $x$  vs.  $t$  and  $v$  vs.  $t$ . Put both cars on same graph; label which line is which car.
- f. Which car is going faster at  $t = 0.2 \text{ s}$ ?

6. In the picture below, a ball starting at rest rolls down a ramp, goes along at the bottom, and then back up a smaller ramp. Ignore friction and air resistance. Sketch the *vertical* position vs. time and *vertical* speed vs. time graphs that accurately describe this motion. Label your graphs with the times indicated in the picture.

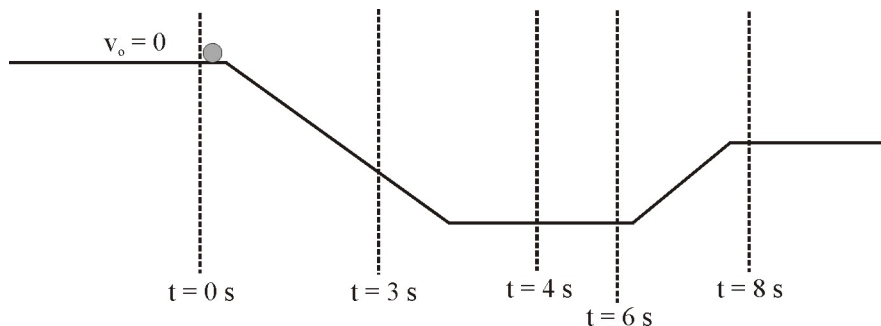

7. Draw the position vs. time graph that corresponds to the velocity vs. time graph below. You may assume a starting position  $x_0 = 0$ . Label both axes of your graph with appropriate values.

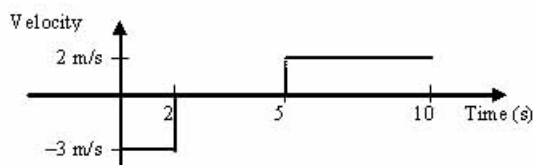

8. Two cars are heading right towards each other, but are 12 km apart. One car is going 70 km/hr and the other is going 50 km/hr. How much time do they have before they collide head on?

9. The following data represent the first 30 seconds of actor Crispin Glover's drive to work.

Time (s)	Position (m)	Distance (m)
0	0	0
5	10	10
10	30	30
15	30	30
20	20	40
25	50	70
30	80	120

- Sketch the graphs of position vs. time and distance vs. time. Label your  $x$  and  $y$  axes appropriately.
- Why is there a discrepancy between the distance covered and the change in position during the time period between  $t = 25$  s and  $t = 30$  s?
- What do you think is going on between  $t = 10$  s and  $t = 15$  s?
- What is the displacement between  $t = 10$  s and  $t = 25$  s?
- What is the distance covered between  $t = 10$  s and  $t = 25$  s?
- What is the average velocity during the first 30 seconds of the trip?
- What is the average velocity between the times  $t = 20$  s and  $t = 30$  s?
- During which time interval(s) was the velocity negative?
- Sketch the velocity vs. time and speed vs. time graphs. Label your  $x$  and  $y$  axes appropriately.

10. Sketchy LeBaron, a used car salesman, claims his car is able to go from 0 to 60 mi/hr in 3.5 seconds.



a. What is the average acceleration of this car? Give your answer in  $\text{m/s}^2$ . (Hint: you will have to perform a conversion.)

b. How much distance does this car cover in these 3.5 seconds? Express your answer twice: in meters and in feet.

c. What is the speed of the car in  $\text{mi/hr}$  after 2 seconds?

11. Michael Jordan had a vertical jump of about 48 inches.

a. Convert this height into meters.

b. Assuming no air resistance, at what speed did he leave the ground?

c. What is his speed  $\frac{3}{4}$  of the way up?

d. What is his speed just before he hits the ground on the way down?

12. You are sitting on your bike at rest. Your brother comes running at you from behind at a speed of  $2\text{m/s}$ . At the exact moment he passes you, you start up on your bike with an acceleration of  $2\text{ m/s}^2$ .

a. Draw a picture of the situation, defining the starting positions, speeds, etc.

b. At what time  $t$  do you have the same speed as your brother?

c. At what time  $t$  do you pass your brother?

d. Draw another picture of the exact moment you catch your brother. Label the drawing with the positions and speeds at that moment.

e. Sketch a position vs. time graph for both you and your brother, labeling the important points (*i.e.*, starting point, when you catch him, etc.)

f. Sketch a speed vs. time graph for both you and your brother, labeling the important points (*i.e.*, starting point, when you catch him, etc.)

13. You are standing at the foot of the Bank of America building in San Francisco, which is 52 floors (237 m) high. You launch a ball straight up in the air from the edge of the foot of the building. The initial vertical speed is  $70\text{ m/s}$ . (For this problem, you may ignore your own height, which is very small compared to the height of the building.)



a. How high up does the ball go?

b. How fast is the ball going right before it hits the top of the building?

c. For how many seconds total is the ball in the air?

14. Measure how high you can jump vertically on Earth. Then, figure out how high you would be able to jump on the Moon, where acceleration due to gravity is  $\frac{1}{6}$ <sup>th</sup> that of Earth. Assume you launch upwards with the same speed on the Moon as you do on the Earth.

15. A car is smashed into a wall during Weaverville's July 4<sup>th</sup> Destruction Derby. The car is going  $25\text{ m/s}$  just before it strikes the wall. It comes to a stop  $0.8$  seconds later. What is the average acceleration of the car during the collision?



16. A helicopter is traveling with a velocity of 12 m/s directly upward. Directly below the helicopter is a very large and very soft pillow. As it turns out, this is a good thing, because the helicopter is lifting a large man. When the man is 20 m above the pillow, he lets go of the rope.

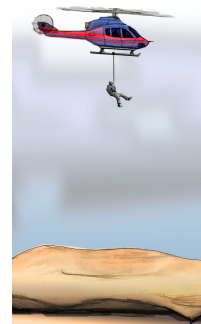

- a. What is the speed of the man just before he lands on the pillow?
- b. How long is he in the air after he lets go?
- c. What is the greatest height reached by the man above the ground? (Hint: this should be greater than 20 m. Why?)
- d. What is the distance between the helicopter and the man three seconds after he lets go of the rope?

17. You are speeding towards a brick wall at a speed of 55 MPH. The brick wall is only 100 feet away.

- a. What is your speed in m/s?
- b. What is the distance to the wall in meters?
- c. What is the minimum acceleration you should use to avoid hitting the wall?

18. What acceleration should you use to increase your speed from 10 m/s to 18 m/s over a distance of 55m?

19. You drop a rock from the top of a cliff. The rock takes 3.5 seconds to reach the bottom.

- a. What is the initial speed of the rock?
- b. What is the magnitude (i.e., *numerical value*) of the acceleration of the rock at the moment it is dropped?
- c. What is the magnitude of the acceleration of the rock when it is half-way down the cliff?
- d. What is the height of the cliff?

20. An owl is flying along above your farm with positions and velocities given by the formulas

$$x(t) = 5.0 + 0.5t + (\frac{1}{2})(0.3)t^2 ; \quad \text{where } t \text{ is in seconds and } x \text{ is in meters from the barn;}$$

$$v(t) = 0.5 + (0.3)t \quad \text{where } v \text{ is in m/s}$$

- a. What is the acceleration of the owl?
- b. What is the speed of the owl at  $t = 0$ ?
- c. Fill in the missing elements of the table.

$t$	$x$	$v$
0.0 s	5 m	.5 m/s
1.0 s	5.65 m	.8 m/s
2.0 s	6.6 m	1.1 m/s
3.0 s		
4.0 s		
5.0 s		
6.0 s		
7.0 s		

8.0 s		
9.0 s		
10.0 s		

d. Plot the  $x$  and  $t$  points on the following graph. Then, connect your points with a smoothly curving line. Be careful and neat and use pencil.

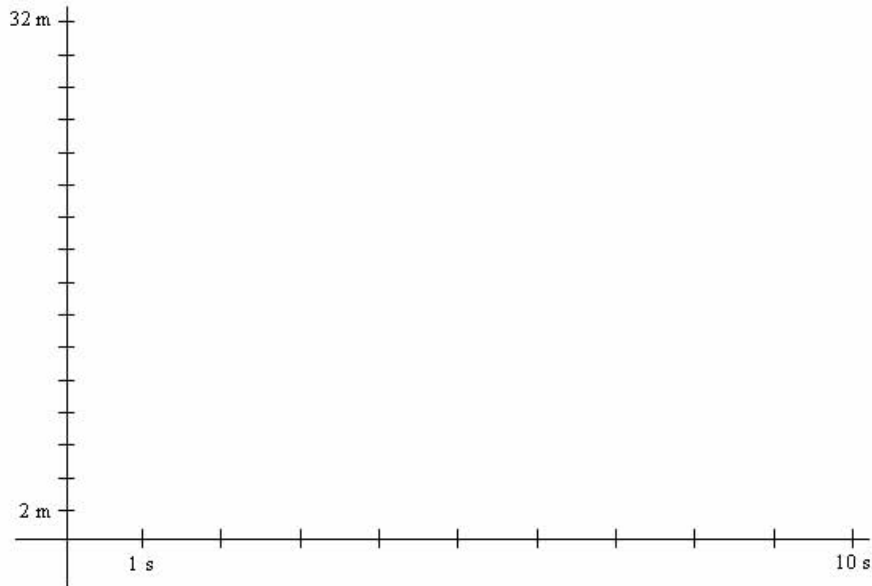

e. Use the formula to calculate the speed of the owl in m/s at  $t = 5$  seconds.

f. Lightly draw in a tangent to your curve at the  $t = 5$  s point. Then, measure the slope of this tangent by measuring the *rise* (in meters) and the *run* (in seconds). What is the slope in m/s?

g. Were your answers to the last two parts the same? If so, why? If not, why not?

h. Fill in the following table. This is going to be harder to do, because you are given  $x$  or  $v$  and are expected to find  $t$ . You may have to use the quadratic formula!

$t$	$x$	$v$
		2.6 m/s
	17.1 m	
		3.14 m/s
	31.4 m	
		5.41 m/s

21. For each of the following graphs, write a few sentences about what kind of motions were made. Try to use the words we have defined in class (speed, velocity, position, acceleration) in your description.

a.

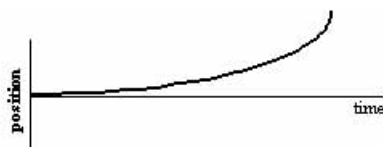

b.

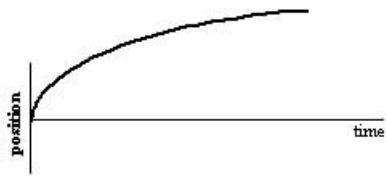

c.

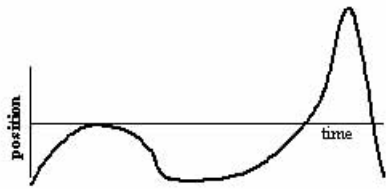

d.

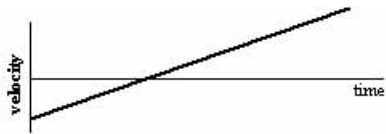

DRAFT

# 5. Two-Dimensional and Projectile Motion

AUTHOR: James H. Dann, Ph.D., James J. Dann SOURCE: The People's Physics Book LICENSE: CCSA

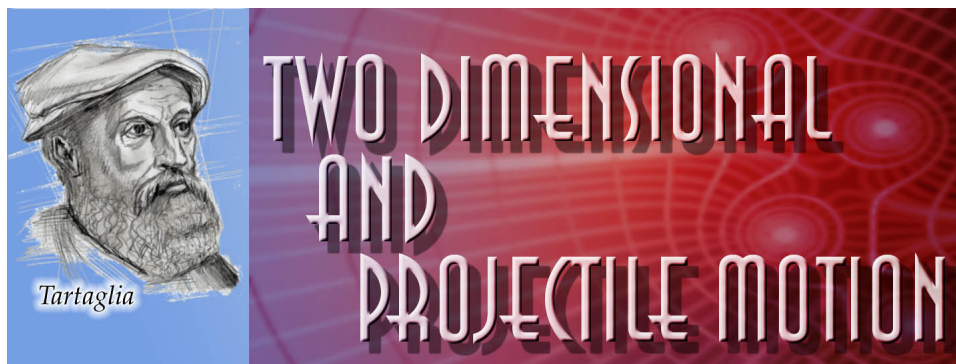

## The Big Idea

In this chapter, we aim to understand and explain the parabolic motion of a thrown object, known as projectile motion. Motion in one direction is unrelated to motion in other perpendicular directions. Once the object has been thrown, the only acceleration is in the  $y$  (up/down) direction. The  $x$  (horizontal) direction velocity remains unchanged.

## Key Equations

<i>In the vertical direction</i>	<i>In the horizontal direction</i>
$y(t) = y_0 + v_{0y}t - \frac{1}{2}gt^2$	$x(t) = x_0 + v_{0x}t$
$v_y(t) = v_{0y} - gt$	$v_x(t) = v_{0x}$
$v_y^2 = v_{0y}^2 - 2g(\Delta y)$	$a_x = 0$
+ $y$ direction is upward	
$a_y = -g = -9.806 \text{ m/s}^2 \approx -10 \text{ m/s}^2$	

*Note:* the initial velocity  $\mathbf{v}_0$  can be separated into  $v_{0x} = v_0 \cos\theta$  and  $v_{0y} = v_0 \sin\theta$ , where  $\theta$  is the angle between the velocity vector and the horizontal.

## Key Concepts

- In projectile motion, the horizontal displacement of an object from its starting point is called its *range*.
- At the top of its flight, the vertical speed of an object in projectile motion is zero.
- To work these problems, separate the “Big Three” equations into two sets: one set for the  $y$ -direction (vertical direction), and one set for the  $x$ -direction (horizontal direction). The  $x$ -direction and  $y$ -direction don’t “talk” to each other. Keep them separate.

- The only variable that can go into both sets of equations is time. You use time to communicate between the two directions.
- Since, in the absence of air resistance, there is no acceleration in the x-direction, the velocity in the x-direction does not change over time. This is a counter-intuitive notion for many. (Air resistance will cause the x-velocity to decrease slightly or significantly depending on the object. But this factor is ignored for the time being.)
- The y-direction motion must include the acceleration due to gravity, and therefore the velocity in the y-direction changes over time.
- The shape of the path of an object undergoing projectile motion is a parabola.
- We will ignore air resistance in this chapter. Air resistance will tend to shorten the range of the projectile motion by virtue of producing an acceleration opposite to the direction of motion.

### Two-Dimensional and Projectile Motion Problem Set

*Draw detailed pictures for each problem (putting in all the data, such as initial velocity, time, etc.), and write down your questions when you get stuck.*

1. Determine which of the following is in projectile motion. Remember that “projectile motion” means that gravity is the only means of acceleration for the object.

- A jet airplane during takeoff
- A baseball during a Barry Bonds home run
- A spacecraft just after all the rockets turn off in Earth orbit
- A basketball thrown towards a basket
- A bullet shot out of a gun
- An inter-continental ballistic missile
- A package dropped out of an airplane as it ascends upward with constant speed

2. Decide if each of the statements below is True or False. Then, explain your reasoning.

- At a projectile’s highest point, its velocity is zero.
- At a projectile’s highest point, its acceleration is zero.
- The rate of change of the x-position is changing with time along the projectile path.
- The rate of change of the y-position is changing with time along the projectile path.
- Suppose that after 2 s, an object has traveled 2 m in the horizontal direction. If the object is in projectile motion, it must travel 2 m in the vertical direction as well.
- Suppose a hunter fires his gun. Suppose as well that as the bullet flies out horizontally and undergoes projectile motion, the shell for the bullet falls directly downward. Then, the shell hits the ground before the bullet.

3. Imagine the path of a soccer ball in projectile motion. Which of the following is true at the highest point in its flight?

- $v_x = 0$ ,  $v_y = 0$ ,  $a_x = 0$ , and  $a_y = 0$

- b.  $v_x > 0$ ,  $v_y = 0$ ,  $a_x = 0$ , and  $a_y = 0$
- c.  $v_x = 0$ ,  $v_y = 0$ ,  $a_x = 0$ , and  $a_y = -9.8 \text{ m/s}^2$
- d.  $v_x > 0$ ,  $v_y = 0$ ,  $a_x = 0$ , and  $a_y = -9.8 \text{ m/s}^2$
- e.  $v_x = 0$ ,  $v_y > 0$ ,  $a_x = 0$ , and  $a_y = -9.8 \text{ m/s}^2$

4. A hunter with an air blaster gun is preparing to shoot at a monkey hanging from a tree. He is pointing his gun directly at the monkey. The monkey's got to think quickly! What is the monkey's best chance to avoid being smacked by the rubber ball?

- a. The monkey should stay right where he is: the bullet will pass beneath him due to gravity.
- b. The monkey should let go when the hunter fires. Since the gun is pointing right at him, he can avoid getting hit by falling to the ground.
- c. The monkey should stay right where he is: the bullet will sail above him since its vertical velocity increases by  $9.8 \text{ m/s}$  every second of flight.
- d. The monkey should let go when the hunter fires. He will fall faster than the bullet due to his greater mass, and it will fly over his head.

5. You are riding your bike in a straight line with a speed of  $10 \text{ m/s}$ . You accidentally drop your calculator out of your backpack from a height of  $2.0 \text{ m}$  above the ground. When it hits the ground, where is the calculator in relation to the position of your backpack? (Neglect air resistance.)

- a. You and your backpack are  $6.3 \text{ m}$  ahead of the calculator.
- b. You and your backpack are directly above the calculator.
- c. You and your backpack are  $6.3 \text{ m}$  behind the calculator.
- d. None of the above.

6. A ball of mass  $m$  is moving horizontally with speed  $v_0$  off a cliff of height  $h$ , as shown. How much time does it take the rock to travel from the edge of the cliff to the ground?

- a.  $\sqrt{hv_0}$
- b.  $h/v_0$
- c.  $hv_0/g$
- d.  $2h/g$
- e.  $\sqrt{2hg}$



7. Find the missing legs or angles of the triangles shown.

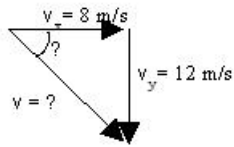
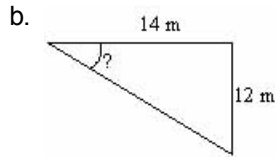
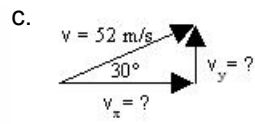
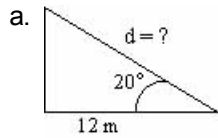

8. Draw in the  $x$ - and  $y$ -velocity components for each dot along the path of the cannonball. The first one is done for you.

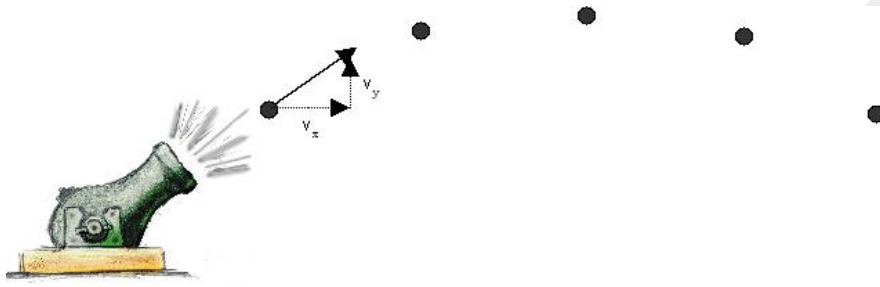

9. A stone is thrown horizontally at a speed of  $8.0 \text{ m/s}$  from the edge of a cliff  $80 \text{ m}$  in height. How far from the base of the cliff will the stone strike the ground?

10. A toy truck moves off the edge of a table that is  $1.25 \text{ m}$  high and lands  $0.40 \text{ m}$  from the base of the table.

a. How much time passed between the moment the car left the table and the moment it hit the floor?

b. What was the horizontal velocity of the car when it hit the ground?

11. A hawk in level flight  $135 \text{ m}$  above the ground drops the fish it caught. If the hawk's horizontal speed is  $20.0 \text{ m/s}$ , how far ahead of the drop point will the fish land?

12. A pistol is fired horizontally toward a target  $120 \text{ m}$  away, but at the same height. The bullet's velocity is  $200 \text{ m/s}$ . How long does it take the bullet to get to the target? How far below the target does the bullet hit?

13. A bird, traveling at  $20 \text{ m/s}$ , wants to hit a waiter  $10 \text{ m}$  below with his dropping (see image). In order to hit the waiter, the bird must release his dropping some distance before he is directly overhead. What is this distance?

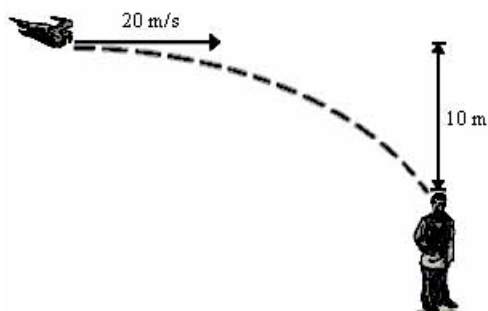

14. Jeff Chandler of the *San Francisco 49ers* kicked a field goal with an initial velocity of 20 m/s at an angle of  $60^\circ$ .
- How long is the ball in the air? *Hint:* you may assume that the ball lands at same height as it starts at.
  - What are the range and maximum height of the ball?
15. A racquetball thrown from the ground at an angle of  $45^\circ$  and with a speed of 22.5 m/s lands exactly 2.5 s later on the top of a nearby building. Calculate the horizontal distance it traveled and the height of the building.
16. Donovan McNabb throws a football. He throws it with an initial velocity of 30 m/s at an angle of  $25^\circ$ . How much time passes until the ball travels 35 m horizontally? What is the height of the ball after 0.5 seconds? (Assume that, when thrown, the ball is 2 m above the ground.)
17. Pedro Feliz throws a baseball with a horizontal component of velocity of 25 m/s. After 2 seconds, the ball is 40 m above the release point. Calculate the horizontal distance it has traveled by this time, its initial vertical component of velocity, and its initial angle of projection. Also, is the ball on the way up or the way down at this moment in time?
18. Barry Bonds hits a 125 m (450') home run that lands in the stands at an altitude 30 m above its starting altitude. Assuming that the ball left the bat at an angle of  $45^\circ$  from the horizontal, calculate how long the ball was in the air.
19. A golfer can drive a ball with an initial speed of 40.0 m/s. If the tee and the green are separated by 100m, but are on the same level, at what angle should the ball be driven? (*Hint:* you should use  $2\cos(x)\sin(x) = \sin(2x)$  at some point.)
20. How long will it take a bullet fired from a cliff at an initial velocity of 700 m/s, at an angle  $30^\circ$  below the horizontal, to reach the ground 200 m below?
21. A diver in Hawaii is jumping off a cliff 45 m high, but she notices that there is an outcropping of rocks 7 m out at the base. So, she must clear a horizontal distance of 7 m during the dive in order to survive. Assuming the diver jumps horizontally, what is his/her minimum push-off speed?
22. If Jason Richardson can jump 1.0 m high on Earth, how high can he jump on the moon assuming same initial velocity that he had on Earth (where gravity is  $1/6$  that of Earth's gravity)?
23. James Bond is trying to jump from a helicopter into a speeding Corvette to capture the bad guy. The car is going 30.0 m/s and the helicopter is flying completely horizontally at 100 m/s. The helicopter is 120 m above the car and 440 m behind the car. How long must James Bond wait to jump in order to safely make it into the car?

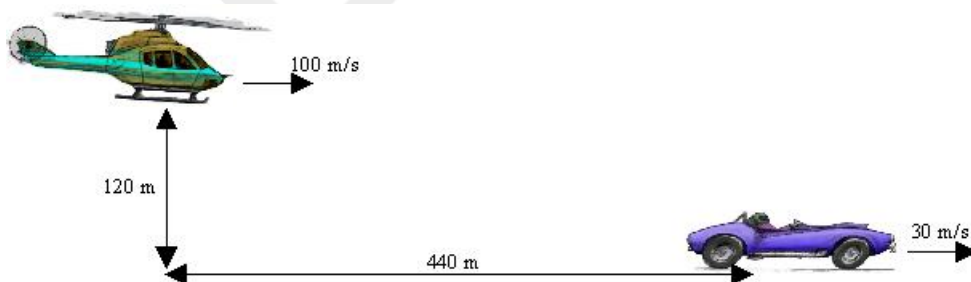



24. A field goal kicker lines up to kick a 44 yard (40 m) field goal. He kicks it with an initial velocity of 22 m/s at an angle of  $55^\circ$ . The field goal posts are 3 meters high.

a. Does he make the field goal?

b. What is the ball's velocity and direction of motion just as it reaches the field goal post (*i.e.*, after it has traveled 40m in the horizontal direction)?

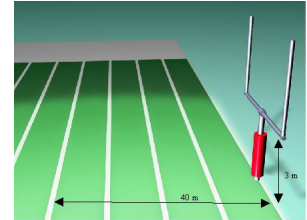

25. In a football game a punter kicks the ball a horizontal distance of 43 yards (39 m). On TV, they track the hang time, which reads 3.9 seconds. From this information, calculate the angle and speed at which the ball was kicked.

*(Note for non-football watchers: the projectile starts and lands at the same height. It goes 43 yards horizontally in a time of 3.9 seconds)*

DRAFT

## 6. Newton's Laws

AUTHOR: James H. Dann, Ph.D., James J. Dann SOURCE: The People's Physics Book LICENSE: CCSA

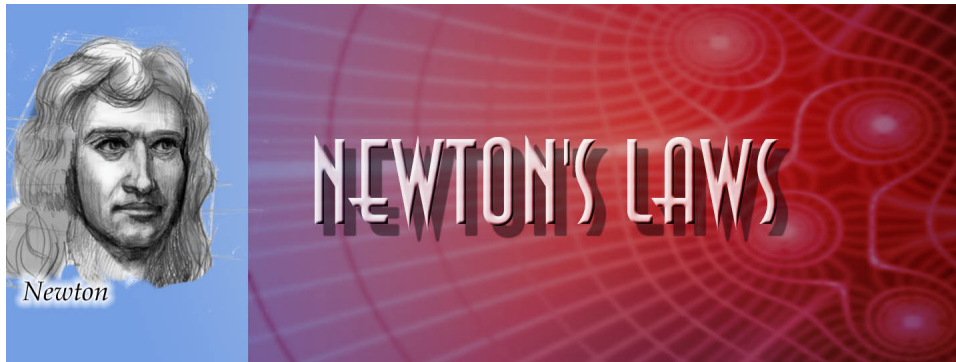

### The Big Idea

Acceleration is caused by force. All forces come in pairs because they arise in the interaction of two objects — you can't hit without being hit back! The more force applied, the greater the acceleration that is produced. Objects with high masses are difficult to accelerate without a large force. In the absence of applied forces, objects simply keep moving at whatever speed and direction they are already going. In formal language (from the Principia in modern English, Isaac Newton, University of California Press, 1934).

- Newton's 1<sup>st</sup> Law:** *Every body continues in its state of rest, or of uniform motion in a right (straight) line, unless it is compelled to change that state by forces impressed upon it.*
- Newton's 2<sup>nd</sup> Law:** *The change of motion is proportional to the motive force impressed; and is made in the direction of the right (straight) line in which that force is impressed.*
- Newton's 3<sup>rd</sup> Law:** *To every action there is always opposed an equal reaction: or, the mutual actions of two bodies upon each other are always equal, and directed to contrary parts.*

Understanding motion comes in two stages. The first stage you've already seen: you can figure out where something will go, and how fast it will get there, if you know its acceleration. The second stage is much more interesting: where did the acceleration come from? How can you predict the amount of acceleration? Mastering both stages is the key to understanding motion.

### Key Concepts

- An object will not change its state of motion (i.e., accelerate) unless an unbalanced force acts on it. Equal and oppositely directed forces do not produce acceleration.
- If no unbalanced force acts on an object the object remains at constant velocity or at rest.
- The force of gravity is called weight and equals  $mg$ , where  $g$  is the acceleration due to gravity of the planet ( $g = 9.8 \text{ m/s}^2$ , downward, on Earth).

- Your mass does not change when you move to other planets, because mass is a measure of how much *matter* your body contains, and not how much gravitational force you feel.
- To calculate the net force on an object, you need to calculate all the individual forces acting on the object and then add them as vectors. This requires some mathematical skill.
- Newton's 3<sup>rd</sup> Law states for every force there is an equal but opposite reaction force. To distinguish a third law pair from merely oppositely directed pairs is difficult, but very important. Third law pairs must obey three rules: (1) Third law force pairs must be of the same type of force. (2) Third law force pairs are exerted on two different objects. (3) Third law force pairs are equal in magnitude and oppositely directed. *Example:* A block sits on a table. The Earth's gravity on the block and the force of the table on the block are equal and opposite. **But these are not third law pairs**, because they are both on the same object and the forces are of different types. The proper third law pairs are: (1) earth's gravity on block/block's gravity on earth and (2) table pushes on block/ block pushes on table.
- If you're asked to evaluate a vector, you may state the x and y components of the vector, or a magnitude and an angle with respect to the horizontal.

### Key Equations

$\mathbf{a} = \mathbf{F}_{\text{net}} / m$	the acceleration produced depends on the net force on an object and its mass.
$\mathbf{F}_{\text{net}} = \Sigma \mathbf{F}_{\text{individual forces}} = m\mathbf{a}$	the net force is the vector sum of all the forces acting on the object.
$F_{\text{net},x} = \Sigma F_{\text{x-direction forces}} = ma_x$	the net force in the x-direction is the sum of all the forces acting on the object in the x- direction.
$F_{\text{net},y} = \Sigma F_{\text{y-direction forces}} = ma_y$	as above, but in the y-direction.
$\mathbf{F}_g = m\mathbf{g}$	the force of gravity acting on an object, often simply called the "weight" of the object. On Earth, $\mathbf{g} = 9.8 \text{ m/s}^2$ in the downward direction.
$\mathbf{F}_N$	the normal force is a contact force that acts in a perpendicular direction to a surface **.
$\mathbf{F}_{\text{sp}} = -k(\Delta \mathbf{x})$	the spring force is the force a coiled spring exerts when it is either compressed or expanded by a displacement $\Delta \mathbf{x}'$ from its resting position.** The spring constant k depends on the strength of the spring, and has units of N/m.
$\mathbf{F}_T$	the force of tension is a force that acts in strings, wires, ropes, and other non-stretchable lines of material.**
$f_s \leq \mu_s F_N$	the force of static friction acts between two surfaces that are in contact, but not in motion with respect to each other. This force prevents objects from sliding. It always opposes potential motion, and it rises in magnitude to a maximum value given by this formula.**
$f_k = \mu_k F_N$	the force of kinetic friction acts between two surfaces that are in contact and in motion with respect to each other. This force slows sliding objects. It always opposes motion.**

\*\* Ultimately, many of these "contact" forces are due to attractive and repulsive electromagnetic forces between atoms in materials.

### Problem Solving for Newton's Laws, Step-By-Step

1. *Figure out which object is "of interest."*

a. If you're looking for the motion of a rolling cart, the cart is the object of interest.

b. If the object of interest is not moving, that's OK, don't panic yet.

c. Draw a sketch! This may help you sort out which object is which in your problem.

2. *Identify all the forces acting on the object and draw them on object. (This is a free-body diagram --FBD)*

a. If the object has mass and is near the Earth, the easiest (and therefore, first) force to write down is the force of gravity, pointing downward, with value  $mg$ .

b. If the object is in contact with a flat surface, it means there is a normal force acting on the object. This normal force points away from and is perpendicular to the surface.

c. There may be more than one normal force acting on an object. For instance, if you have a bologna sandwich, remember that the slice of bologna feels normal forces from both the slices of bread!

d. If a rope, wire, or cord is pulling on the object in question, you've found yourself a tension force. The direction of this force is in the same direction that the rope is pulling.

e. Don't worry about any forces acting on other objects. For instance, if you have a bologna sandwich as your object of interest, and you're thinking about the forces acting on the slice of bologna, don't worry about the force of gravity acting on either piece of bread.

f. Remember that Newton's 3rd Law, calling for "equal and opposite forces," does not apply to a single object. None of your forces should be "equal and opposite" on the same object in the sense of Newton's 3rd Law. Third law pairs act on two different objects.

g. Recall that scales (like a bathroom scale you weigh yourself on) read out the normal force acting on you, not your weight. If you are at rest on the scale, the normal force equals your weight. If you are accelerating up or down, the normal force had better be higher or lower than your weight, or you won't have an unbalanced force to accelerate you.

h. Never include " $ma$ " as a force acting on an object. " $ma$ " is the *result* for which the net force  $F_{\text{net}}$  is the *cause*.

3. *Identify which forces are in the x-direction, which are in the y-direction, and which are at an angle.*

a. If a force is upward, make it in the y-direction and give it a positive sign. If it is downward, make it in the y-direction and give it a negative sign.

b. Same thing applies for right vs. left in the x-direction. Make rightward forces positive.

c. If forces are at an angle, draw them at an angle. A great example is that when a dog on a leash runs ahead, pulling you along, it's pulling both forward *and* down on your hand.

d. Draw the free body diagram (FBD).

e. Remember that the FBD is supposed to be helping you with your problem. For instance, if you forget a force, it'll be really obvious on your FBD.

4. *Break the forces that are at angles into their x and y components.*

a. Use right triangle trigonometry

b. Remember that these components aren't *new* forces, but are just what makes up the forces you've already identified.

c. Consider making a second FBD to do this component work, so that your first FBD doesn't get too messy.

5. Add up all the x-forces and x-components.

- a. Remember that all the rightward forces add with a plus (+) sign, and that all the leftward forces add with a minus (-) sign.
- b. Don't forget about the x-components of any forces that are at an angle!
- c. When you've added them all up, call this "the sum of all x forces" or "the net force in the x-direction."

6. Add up all the y-forces and y-components.

- a. Remember that all the upward forces add with a (+) sign, all the downward forces add with a (-) sign.
- b. Don't forget about the y-components of any forces that are at an angle!
- c. When you've added them all up, call this "the sum of all y forces" or "net force in the y-direction."

7. Use Newton's Laws twice.

- a. The sum of all x-forces, divided by the mass, is the object's acceleration in the x-direction.
- b. The sum of all y-forces, divided by the mass, is the object's acceleration in the y-direction.
- c. If you happen to know that the acceleration in the x-direction or y-direction is zero (say the object is just sitting on a table), then you can plug this in to Newton's 2<sup>nd</sup> Law directly.
- d. If you happen to know the acceleration, you can plug this in directly too.

8. Each body should have a FBD.

- a. Draw a separate FBD for each body.
- b. Set up a  $\Sigma f = ma$  equation based on the FBD for each body.
- c. Newton's Third Law will tell you which forces on different bodies are the same in magnitude.
- d. Your equations should equal your unknown variables at this point.

### **Newton's Laws Problem Set**

1. A VW Bug hits a huge truck head-on. Each vehicle was initially going 50 MPH.
  - a. Which vehicle experiences the greater force?
  - b. Which experiences the greater acceleration?
2. Is it possible for me to wave my hand and keep the rest of my body perfectly still? Why or why not?
3. How does a rocket accelerate in space, where there is nothing to 'push off' against?
4. Is there a net force on a hammer when you hold it steady above the ground? If you let the hammer drop, what's the net force on the hammer while it is falling to the ground?
5. If an object is moving at constant velocity or at rest, what is the minimum number of forces acting on it (other than zero)?
6. If an object is accelerating, what is the minimum number of forces acting on it?

7. You are standing on a bathroom scale. Can you reduce your weight by pulling up on your shoes? (Try it.)

8. When pulling a paper towel from a paper towel roll, why is a quick jerk more effective than a slow pull?

9. You and your friend are standing on identical skateboards with an industrial-strength compressed spring in between you. After the spring is released, it falls straight to the ground and the two of you fly apart.

a. If you have identical masses, who travels farther?

b. If your friend has a bigger mass who goes farther?

c. If your friend has a bigger mass who feels the larger force?

d. If you guys have identical masses, even if you push on the spring, why isn't it possible to go further than your friend?

10. Explain the normal force in terms of the microscopic forces between molecules in a surface.

11. A stone with a mass of 10 kg is sitting on the ground, not moving.

a. What is the weight of the stone?

b. What is the normal force acting on the stone?

12. The stone from the last question is now being pulled horizontally along the ground at constant speed in the positive  $x$  direction. Is there a net force on the stone?

13. A spring with spring constant  $k = 400$  N/m has an uncompressed length of 0.23 m. When fully compressed, it has a length of 0.15 m. What force is required to fully compress the spring?

14. Measuring velocity is hard: for instance, can you tell how fast you're going around the Sun right now? Measuring acceleration is comparatively easy — you can *feel* accelerations. Here's a clever way to determine your acceleration. As you accelerate your car on a flat stretch, you notice that the fuzzy dice hanging from your rearview mirror are no longer hanging straight up and down. In fact, they are making a  $30^\circ$  angle with respect to the vertical. What is your acceleration? (Hint: Draw a FBD. Consider both  $x$  and  $y$  equations.)

15. Draw free body diagrams (FBDs) for all of the following objects involved (in **bold**) and label all the forces appropriately. Make sure the lengths of the vectors in your FBDs are proportional to the strength of the force: smaller forces get shorter arrows!

a. A **man** stands in an elevator that is accelerating upward at  $2$  m/s<sup>2</sup>.

b. A boy is dragging a **sled** at a constant speed. The boy is pulling the sled with a rope at a  $30^\circ$  angle.

c. Your **foot** presses against the ground as you walk.

d. The **picture** shown here is attached to the ceiling by three wires.

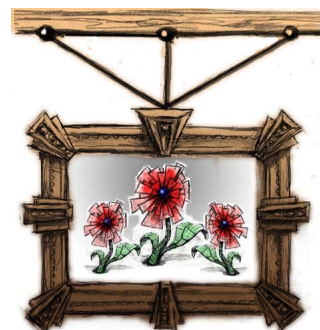

16. Analyze the situation shown here with a big kid pulling a little kid in a wagon. You'll notice that there are a lot of different forces acting on the system. Let's think about what happens the moment the sled begins

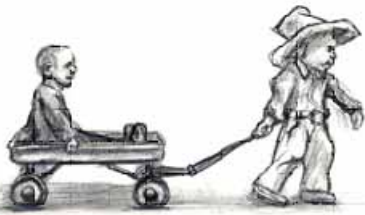

to move.

- First, draw the free body diagram of the big kid. Include all the forces you can think of, including friction. Then do the same for the little kid.
- Identify all third law pairs. Decide which forces act on the two body system and which are extraneous.
- Explain what conditions would make it possible for the two-body system to move forward.

17. Break the force vector  $\mathbf{F}$  on the right into its  $x$  and  $y$  components,  $F_x$  and  $F_y$ .

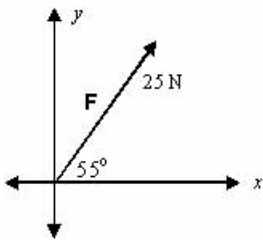

18. For both figures below, find the net force and its direction (*i.e.*, the magnitude of  $\mathbf{F} = \mathbf{F}_1 + \mathbf{F}_2$  and the angle it makes with the  $x$ -axis). Draw in  $\mathbf{F}$ .

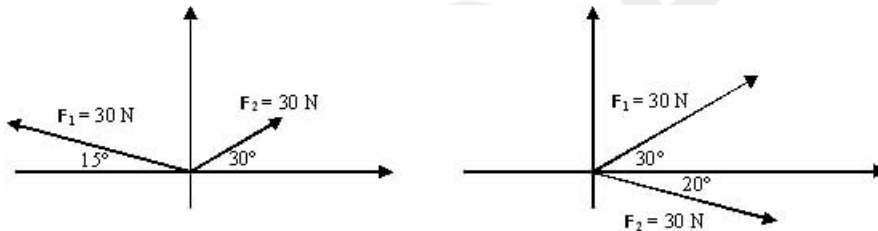

19. Andreas and Kaya are pulling a wagon. Andreas is pulling with a force of 50 N towards the northeast. Kaya is pulling with a force of 50 N towards the southeast. The wagon has a mass of 23 kg. What is the acceleration and direction of motion of the wagon?

20. Laura and Alan are pulling a wagon. Laura is pulling with a force of 50 N towards the northeast. Alan is pulling with a force of 50 N directly east. The wagon has a mass of 23 kg. What is the acceleration and direction of motion of the wagon?

21. When the 20 kg box to the right is pulled with a force of 100 N, it just starts to move (*i.e.*, the maximum value of static friction is overcome with a force of 100 N). What is the value of the coefficient of static friction,  $\mu_s$ ?



22. A different box, this time 5 kg in mass, is being pulled with a force of 20 N and is sliding with an acceleration of  $2 \text{ m/s}^2$ . Find the coefficient of kinetic friction,  $\mu_k$ .



23. The man is hanging from a rope wrapped around a pulley and attached to both of his shoulders. The pulley is fixed to the wall. The rope is designed to hold 500 N of weight; at higher tension, it will break. Let's say he has a mass of 80 kg. Draw a free body diagram and explain (using Newton's Laws) whether or not the rope will break.



24. Now the man ties one end of the rope to the ground and is held up by the other. Does the rope break in this situation? What precisely is the difference between this problem and the one before?



25. For a boy who weighs 500 N on Earth what are his mass and weight on the moon (where  $g = 1.6 \text{ m/s}^2$ )?

26. A woman of mass 70.0 kg weighs herself in an elevator.





- a. If she wants to weigh less, should she weigh herself when accelerating upward or downward?
- b. When the elevator is not accelerating, what does the scale read (i.e., what is the normal force that the scale exerts on the woman)?
- c. When the elevator is accelerating upward at  $2.00 \text{ m/s}^2$ , what does the scale read?

27. A crane is lowering a box of mass  $50 \text{ kg}$  with an acceleration of  $2.0 \text{ m/s}^2$ .

- a. Find the tension  $F_T$  in the cable.
- b. If the crane lowers the box at a constant speed, what is the tension  $F_T$  in the cable?

28. The large box on the table is  $30 \text{ kg}$  and is connected via a rope and pulley to a smaller  $10 \text{ kg}$  box, which is hanging. The  $10 \text{ kg}$  mass is the highest mass you can hang without moving the box on the table. Find the coefficient of static friction  $\mu_s$ .

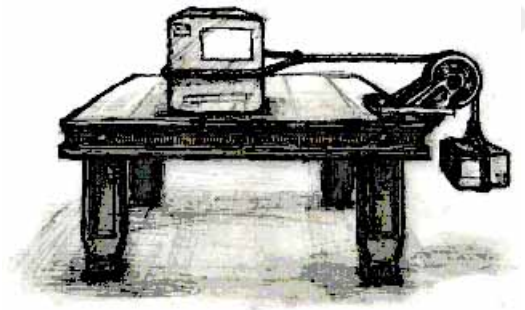

29. Find the mass of the painting. The tension in the leftmost rope is  $7.2 \text{ N}$ , in the middle rope it is  $16 \text{ N}$ , and in the rightmost rope it is  $16 \text{ N}$ .

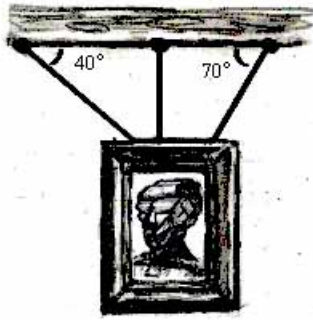

30. Find Brittany's acceleration down the frictionless waterslide in terms of her mass  $m$ , the angle  $\theta$  of the incline, and the acceleration of gravity  $g$ .

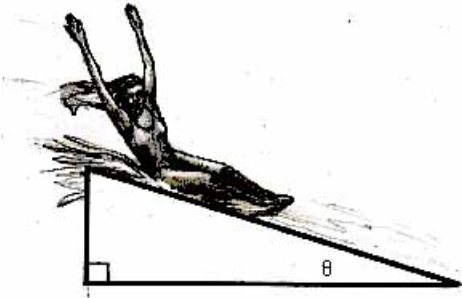

31. The physics professor holds an eraser up against a wall by pushing it directly against the wall with a completely horizontal force of 20 N. The eraser has a mass of 0.5 kg. The wall has coefficients of friction  $\mu_s = 0.8$  and  $\mu_k = 0.6$ .

- Draw a free body diagram for the eraser.
- What is the normal force  $F_N$  acting on the eraser?
- What is the frictional force  $F_s$  equal to?
- What is the maximum mass  $m$  the eraser could have and still not fall down?
- What would happen if the wall and eraser were both frictionless?



32. A tractor of mass 580 kg accelerates up a  $10^\circ$  incline from rest to a speed of 10 m/s in 4 s. For all of answers below, provide a magnitude and a direction.

- What net force  $F_{net}$  has been applied to the tractor?
- What is the normal force,  $F_N$  on the tractor?
- What is the force of gravity  $F_g$  on the tractor?
- What force has been applied to the tractor so that it moves up-hill?
- What is the source of this force?



33. A heavy box (mass 25 kg) is dragged along the floor by a kid at a 30° angle to the horizontal with a force of 80 N (which is the maximum force the kid can apply).



- Draw the free body diagram.
- What is the normal force  $F_N$  ?
- Does the normal force decrease or increase as the angle of pull increases? Explain.
- Assuming no friction, what is the acceleration of the box?
- Assuming it begins at rest, what is its speed after ten seconds?
- Is it possible for the kid to lift the box by pulling straight up on the rope?
- In the absence of friction, what is the net force in the x-direction if the kid pulls at a 30° angle?
- In the absence of friction, what is the net force in the x-direction if the kid pulls at a 45° angle?
- In the absence of friction, what is the net force in the x-direction if the kid pulls at a 60° angle?
- The kid pulls the box at constant velocity at an angle of 30°. What is the coefficient of kinetic friction  $\mu_K$  between the box and the floor?
- The kid pulls the box at an angle of 30°, producing an acceleration of 2 m/s<sup>2</sup>. What is the coefficient of kinetic friction  $\mu_K$  between the box and the floor?

34. For the following situation, identify the 3<sup>rd</sup> law force pairs on the associated free body diagrams. Label each member of one pair "A," each member of the next pair "B," and so on. The spring is stretched so that it is pulling the block of wood to the right.

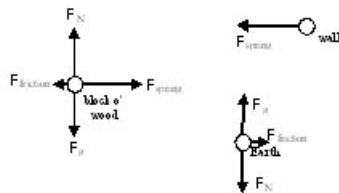
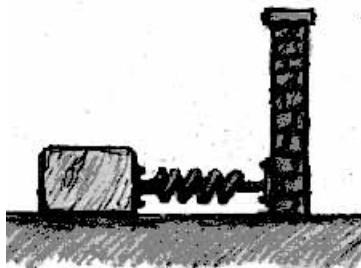

Draw free body diagrams for the situation below. Notice that we are pulling the bottom block *out from beneath* the top block. There is friction between the blocks! After you have drawn your FBDs, identify the 3<sup>rd</sup> law force pairs, as above.

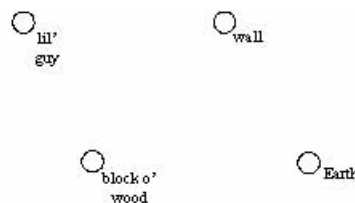
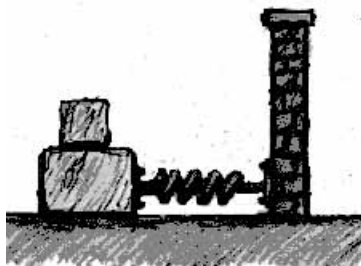

35. Spinal implant problem — this is a real life bio-med engineering problem!

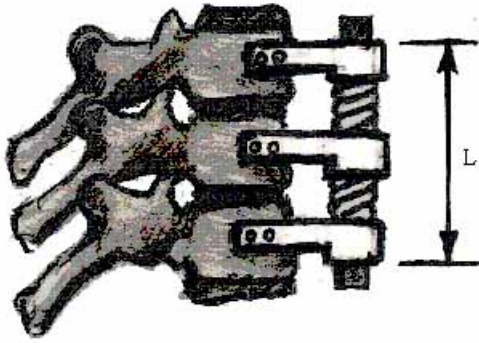

Here's the situation: both springs are compressed by an amount  $x_0$ . The rod of length  $L$  is fixed to both the top plate and the bottom plate. The two springs, each with spring constant  $k$ , are wrapped around the rod on both sides of the middle plate, but are free to move because they are not attached to the rod or the plates. The middle plate has negligible mass, and is constrained in its motion by the compression forces of the top and bottom springs.

The medical implementation of this device is to screw the top plate to one vertebrae and the middle plate to the vertebrae directly below. The bottom plate is suspended in space. Instead of fusing broken vertebrae together, this implant allows movement somewhat analogous to the natural movement of functioning vertebrae. Below you will do the exact calculations that an engineer did to get this device patented and available for use at hospitals.

- Find the force,  $F$ , on the middle plate for the region of its movement  $\Delta x \leq x_0$ . Give your answer in terms of the constants given. (*Hint: In this region both springs are providing opposite compression forces.*)
- Find the force,  $F$ , on the middle plate for the region of its movement  $\Delta x \geq x_0$ . Give your answer in terms of the constants given. (*Hint: In this region, only one spring is in contact with the middle plate.*)
- Graph  $F$  vs.  $x$ . Label the values for force for the transition region in terms of the constants given.

36. You design a mechanism for lifting boxes up an inclined plane by using a vertically hanging mass to pull them, as shown in the figure below.

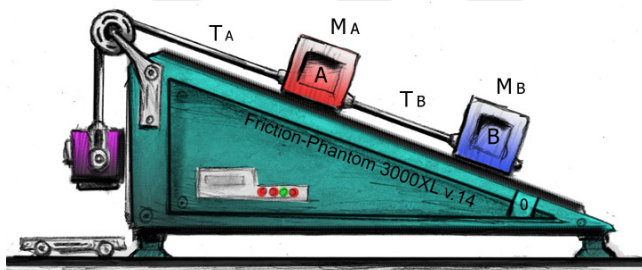

The pulley at the top of the incline is massless and frictionless. The larger mass,  $M$ , is accelerating downward with a measured acceleration  $a$ . The smaller masses are  $m_A$  and  $m_B$ ; the angle of the incline is  $\theta$ , and the coefficient of kinetic friction between each of the masses and the incline has been measured and determined to be  $\mu_k$ .

- Draw free body diagrams for each of the three masses.
- Calculate the magnitude of the frictional force on each of the smaller masses in terms of the given quantities.

- c. Calculate the net force on the hanging mass in terms of the given quantities.
- d. Calculate the magnitudes of the two tension forces  $T_A$  and  $T_B$  in terms of the given quantities.
- e. Design and state a strategy for solving for how long it will take the larger mass to hit the ground, assuming at this moment it is at a height  $h$  above the ground. Do not attempt to solve this: simply state the strategy for solving it.

37. You build a device for lifting objects, as shown below. A rope is attached to the ceiling and two masses are allowed to hang from it. The end of the rope passes around a pulley (right) where you can pull it downward to lift the two objects upward. The angles of the ropes, measured with respect to the vertical, are shown. Assume the bodies are at rest initially.

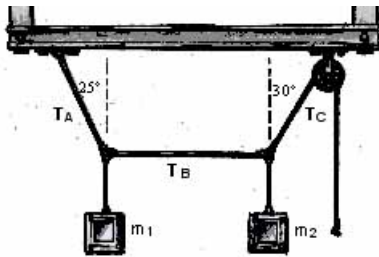

- a. Suppose you are able to measure the masses  $m_1$  and  $m_2$  of the two hanging objects as well as the tension  $T_C$ . Do you then have enough information to determine the other two tensions,  $T_A$  and  $T_B$ ? Explain your reasoning.
- b. If you only knew the tensions  $T_A$  and  $T_C$ , would you have enough information to determine the masses  $m_1$  and  $m_2$ ? If so, write  $m_1$  and  $m_2$  in terms of  $T_A$  and  $T_C$ . If not, what further information would you require?

38. A stunt driver is approaching a cliff at very high speed. Sensors in his car have measured the acceleration and velocity of the car, as well as all forces acting on it, for various times. The driver's motion can be broken down into the following steps:



Step 1: The driver, beginning at rest, accelerates his car on a horizontal road for ten seconds. Sensors show that there is a force in the direction of motion of 6000 N, but additional forces acting in the opposite direction with magnitude 1000 N. The mass of the car is 1250 kg.

Step 2: Approaching the cliff, the driver takes his foot off of the gas pedal (There is no further force in the direction of motion.) and brakes, increasing the force opposing motion from 1000 N to 2500 N. This continues for five seconds until he reaches the cliff.

Step 3: The driver flies off the cliff, which is 44.1 m high and begins projectile motion.

- a. Ignoring air resistance, how long is the stunt driver in the air?
- b. For Step 1:
- Draw a free body diagram, naming all the forces on the car.
  - Calculate the magnitude of the net force.
  - Find the change in velocity over the stated time period.
  - Make a graph of velocity in the  $x$ -direction vs. time over the stated time period.
  - Calculate the distance the driver covered in the stated time period. Do this by finding the area under the curve in your graph of (iv). Then, check your result by using the equations for kinematics.

c. Repeat (b) for Step 2.

d. Calculate the distance that the stunt driver should land from the bottom of the cliff.

39. You are pulling open a stuck drawer, but since you're a physics geek you're pulling it open with an electronic device that measures force! You measure the following behavior. The drawer has a weight of 7N.

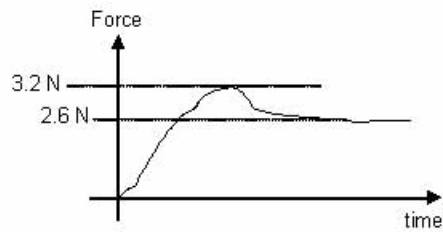

Draw a graph of friction force vs. time.

40. Draw arrows representing the **forces** acting on the cannonball as it flies through the air. Assume that air resistance is small compared to gravity, but not negligible.



41. A tug of war erupts between you and your sweetie. Assume your mass is 60 kg and the coefficient of friction between your feet and the ground is 0.5 (good shoes). Your sweetie's mass is 85 kg and the coefficient of friction between his/her feet and the ground is 0.35 (socks). Who is going to win? Explain, making use of a calculation.

42. A block has a little block hanging out to its side, as shown:



As you know, if the situation is left like this, the little block will just fall. But if we accelerate the leftmost block to the right, this will create a normal force between the little block and the big block, and if there is a coefficient of friction between them, then the little block won't slide down! Clever, eh?

a. The mass of the little block is 0.15 kg. What frictional force is required to keep it from falling? (State a magnitude and direction.)

b. If both blocks are accelerating to the right with an acceleration  $a = 14.0 \text{ m/s}^2$ , what is the normal force on the little block provided by the big block?

c. What is the minimum coefficient of static friction required?



# 7. Centripetal Forces

AUTHOR: James H. Dann, Ph.D., James J. Dann SOURCE: The People's Physics Book LICENSE: CCSA



## The Big Idea

In the absence of a net force, objects move in a straight line. If they turn — that is, if their velocity changes, *even only in direction* — there must be an applied force. Forces which cause objects to turn around continuously in a circle are known as *centripetal* forces. When an object moves in a circle its velocity at any particular instant points in a direction *tangent* to the circle. The acceleration points towards the center of the circle, and so does the force acting on it. This is only natural, when you think about it — if you feel a force pushing you towards your left as you walk forward, you will walk in a circle, always turning left.

## Key Equations

$F_c = mv^2 / r$	if an object of mass $m$ moves in a circle of radius $r$ at speed $v$ , the force acting on it must be equal to this value. The direction of this force is always pointed towards the center of the circle.
$F_g = Gm_1m_2 / r^2$	every pair of objects in the world has a mutual attraction called gravity. This formula allows you to predict this force. Gravity is the reason the Earth circles the sun.

## Key Concepts

- An orbital period,  $T$ , is the time it takes to make one complete rotation.

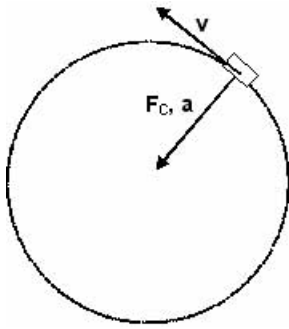

- If a particle travels a distance  $2\pi r$  in an amount of time  $T$ , then its speed is distance over time or  $2\pi r/T$ .
- An object moving in a circle has an instantaneous velocity vector *tangential* to the circle of its path. The force and acceleration vectors point to the center of the circle.
- Net force and acceleration *always* have the same direction.
- Centripetal acceleration is just the acceleration provided by centripetal forces.
- Geosynchronous orbit is when a satellite completes one orbit of the Earth every 24 hours, staying above the same spot on Earth.

### Key Applications

- To find the maximum speed that a car can take a corner on a flat road without skidding out, set the force of friction equal to the centripetal force.
- To find the tension in the rope of a swinging pendulum, remember that it is the *sum* of the tension and gravity that produces a net upward centripetal force. A common mistake is just setting the centripetal force equal to the tension.
- To find the speed of a planet or satellite in an orbit, set the force of gravity equal to the centripetal force.

### Centripetal Forces Problem Set

1. When you make a right turn at constant speed in your car what is the force that causes *you* (not the car) to change the direction of *your* velocity? Choose the best possible answer.

- Friction between your butt and the seat
- Inertia
- Air resistance
- Tension
- All of the above
- None of the above

2. You buy new tires for your car in order to take turns a little faster (uh, not advised — always drive slowly). The new tires double your coefficient of friction with the road. With the old tires you could take a particular turn at a speed  $v_0$ . What is the maximum speed you can now take the turn without skidding out?



- a.  $4v_0$
- b.  $2v_0$
- c.  $v_0$
- d.  $\sqrt{2}v_0$
- e. Not enough information given

3. A pendulum consisting of a rope with a ball attached at the end is swinging back and forth. As it swings downward to the right the ball is released at its lowest point. Decide which way the ball attached at the end of the string will go at the moment it is released.



- a. Straight upwards
- b. Straight downwards
- c. Directly right
- d. Directly left
- e. It will stop

4. A ball is spiraling outward in the tube shown to the right. Which way will the ball go after it leaves the tube?

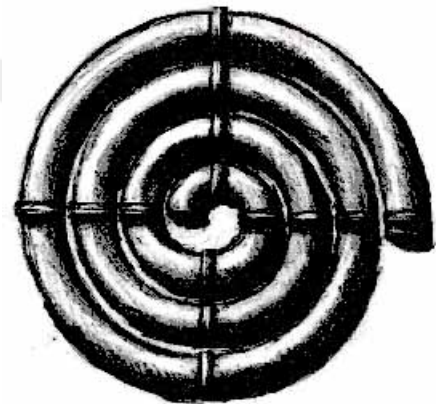

- a. Towards the top of the page
- b. Towards the bottom of the page
- c. Continue spiraling outward in the clockwise direction
- d. Continue in a circle with the radius equal to that of the spiral as it leaves the tube
- e. None of the above

5. An object of mass 10 kg is in a circular orbit of radius 10 m at a velocity of 10 m/s.

- a. Calculate the centripetal force (in N) required to maintain this orbit.
- b. What is the acceleration of this object?

6. Suppose you are spinning a child around in a circle by her arms. The radius of her orbit around you is 1 meter. Her speed is 1 m/s. Her mass is 25 kg.

- a. What is the tension in your arms?
- b. In her arms?

7. A racecar is traveling at a speed of 80.0 m/s on a circular racetrack of radius 450 m.

- a. What is its centripetal acceleration in  $\text{m/s}^2$ ?
- b. What is the centripetal force on the racecar if its mass is 500 kg?

c. What provides the necessary centripetal force in this case?

8. The radius of the Earth is 6380 km. Calculate the velocity of a person standing at the equator due to the Earth's 24 hour rotation. Calculate the centripetal acceleration of this person and express it as a fraction of the acceleration  $g$  due to gravity. Is there any danger of "flying off"?

9. Neutron stars are the corpses of stars left over after supernova explosions. They are the size of a small city, but can spin several times per second. (Try to imagine this in your head.) Consider a neutron star of radius 10 km that spins with a period of 0.8 seconds. Imagine a person is standing at the equator of this neutron star.

a. Calculate the centripetal acceleration of this person and express it as a multiple of the acceleration  $g$  due to gravity (on Earth).

b. Now, find the minimum acceleration due to gravity that the neutron star must have in order to keep the person from flying off.

10. Calculate the force of gravity between the Sun and the Earth. (The relevant data are included in Appendix B.)

11. Calculate the force of gravity between two human beings, assuming that each has a mass of 80 kg and that they are standing 1 m apart. Is this a large force?

12. Prove  $g$  is *approximately*  $10 \text{ m/s}^2$  on Earth by following these steps:

a. Calculate the force of gravity between a falling object (for example an apple) and that of Earth. Use the symbol  $m_o$  to represent the mass of the falling object.

b. Now divide that force by the object's mass to find the acceleration  $g$  of the object.

13. Our Milky Way galaxy is orbited by a few hundred "globular" clusters of stars, some of the most ancient objects in the universe. Globular cluster M13 is orbiting at a distance of 26,000 light-years (one light-year is  $9.46 \times 10^{15} \text{ m}$ ) and has an orbital period of 220 million years. The mass of the cluster is  $10^6$  times the mass of the Sun.

a. What is the amount of centripetal force required to keep this cluster in orbit?

b. What is the source of this force?

c. Based on this information, what is the mass of our galaxy? If you assume that the galaxy contains nothing, but Solar-mass stars (each with an approximate mass of  $2 \times 10^{30} \text{ kg}$ ), how many stars are in our galaxy?

14. Calculate the centripetal acceleration of the Earth around the Sun.

15. You are speeding around a turn of radius 30.0 m at a constant speed of 15.0 m/s.

a. What is the minimum coefficient of friction  $\mu$  between your car tires and the road necessary for you to retain control?

b. Even if the road is terribly icy, you will still move in a circle because you are slamming into the walls. What centripetal forces must the walls exert on you if you do not lose speed? Assume  $m = 650 \text{ kg}$ .

16. Calculate the gravitational force that your pencil or pen pulls on you. Use the center of your chest as the center of mass (and thus the mark for the distance measurement) and estimate all masses and distances.



a. If there were no other forces present, what would your acceleration be towards your pencil? Is this a large or small acceleration?

b. Why, in fact, doesn't your pencil accelerate towards you?

17. A digital TV satellite is placed in geosynchronous orbit around Earth, so it is always in the same spot in the sky.

a. Using the fact that the satellite will have the same period of revolution as Earth, calculate the radius of its orbit.

b. What is the ratio of the radius of this orbit to the radius of the Earth?

c. Draw a sketch, to scale, of the Earth and the orbit of this digital TV satellite.

d. If the mass of the satellite were to double, would the radius of the satellite's orbit be larger, smaller, or the same? Why?

18. A top secret spy satellite is designed to orbit the Earth twice each day (*i.e.*, twice as fast as the Earth's rotation). What is the height of this orbit above the Earth's surface?

19. Two stars with masses  $3.00 \times 10^{31}$  kg and  $7.00 \times 10^{30}$  kg are orbiting each other under the influence of each other's gravity. We want to send a satellite in between them to study their behavior. However, the satellite needs to be at a point where the gravitational forces from the two stars are equal. The distance between the two stars is  $2.0 \times 10^{10}$  m. Find the distance from the more massive star to where the satellite should be placed. (*Hint*: Distance from the satellite to one of the stars is the variable.)

20. Calculate the mass of the Earth using *only*: (i) Newton's Universal Law of Gravity; (ii) the Moon-Earth distance (Appendix B); and (iii) the fact that it takes the Moon 27 days to orbit the Earth.

21. A student comes up to you and says, "I can visualize the force of tension, the force of friction, and the other forces, but I can't visualize *centripetal* force." As you know, a centripetal force must be *provided* by tension, friction, or some other "familiar" force. Write a two or three sentence explanation, in your own words, to help the confused student.

22. A space station was established far from the gravitational field of Earth. Extended stays in zero gravity are not healthy for human beings. Thus, for the comfort of the astronauts, the station is rotated so that the astronauts *feel* there is an internal gravity. The rotation speed is such that the *apparent* acceleration of gravity is  $9.8 \text{ m/s}^2$ . The direction of rotation is counter-clockwise.



a. If the radius of the station is 80 m, what is its rotational speed,  $v$ ?

b. Draw vectors representing the astronaut's velocity and acceleration.

c. Draw a free body diagram for the astronaut.

d. Is the astronaut exerting a force on the space station? If so, calculate its magnitude. Her mass  $m=65\text{kg}$ .

e. The astronaut drops a ball, which *appears* to accelerate to the 'floor,' (see picture) at  $9.8 \text{ m/s}^2$ .

- i. Draw the velocity and acceleration vectors for the ball while it is in the air.
- ii. What force(s) are acting on the ball while it is in the air?
- iii. Draw the acceleration and velocity vectors after the ball hits the floor and comes to rest.
- iv. What force(s) act on the ball after it hits the ground?



DRAFT

# 8. Momentum Conservation

AUTHOR: James H. Dann, Ph.D., James J. Dann SOURCE: The People's Physics Book LICENSE: CCSA



## The Big Idea

The universe has many remarkable qualities, among them a rather beautiful symmetry: the total amount of motion in the universe balances out...always. This law only makes sense if we measure “motion” in a specific way: as the product of mass and velocity. This product, called *momentum*, can be exchanged from one object to another in a collision. The rapidity with which momentum is exchanged over time is determined by the forces involved in the collision. This is the second of the five fundamental conservation laws in physics. The other four are conservation of energy, angular momentum, charge and CPT. (See Feynman's Diagrams for an explanation of CPT.)

## Key Equations

$\mathbf{p} = m\mathbf{v}$	The momentum vector points in the same direction as the velocity vector, but its length depends on both the mass and the speed of the object. To get the magnitude, just multiply the mass by the speed.
$\mathbf{F} = \Delta\mathbf{p}/\Delta t$	Note that $\Delta\mathbf{p}/\Delta t = m\Delta\mathbf{v}/\Delta t = m\mathbf{a}$ . This is just Newton's 2 <sup>nd</sup> Law!
$\sum \mathbf{p}_i = \sum \mathbf{p}_f$	The sum of all the momenta before a collision equals the sum of all the momenta after the collision. When adding up momenta, be sure to add them as vectors, and to include all the objects in the system.

## Key Concepts

- Momentum is a vector that points in the direction of the velocity vector. The magnitude of this vector is the product of mass and speed.
- The total momentum of the universe is always the same and is equal to zero. The total momentum of an isolated system never changes.
- Momentum can be transferred from one body to another. In an isolated system in which momentum is transferred internally, the total initial momentum is the same as the total final momentum.

- Momentum conservation is especially important in collisions, where the total momentum just before the collision is the same as the total momentum after the collision.
- The force imparted on an object is equal to the change in momentum divided by the time interval over which the objects are in contact.
- *Internal forces* are forces for which both Newton's 3<sup>rd</sup> Law force pairs are contained within the system. For example, consider a two-car head-on collision. Define the *system* as just the two cars. In this case, internal forces include that of the fenders pushing on each other, the contact forces between the bolts, washers, and nuts in the engines, etc.
- *External forces* are forces that act on the system from outside. In our previous example, external forces include the force of gravity acting on both cars (because the other part of the force pair, the pull of gravity the Earth experiences coming from the cars, is not included in the system) and the forces of friction between the tires and the road.
- If there are no external forces acting on a system of objects, the initial momentum of the system will be the same as the final momentum of the system. Otherwise, the final momentum will change by  $\Delta\mathbf{p}=\mathbf{F}\Delta t$ . We call a change in momentum,  $\Delta\mathbf{p}$ , an *impulse*.

### Key Applications

- Two cars collide head-on...two subatomic particles collide in an accelerator...a bird slams into a glass office building: all of these are examples of one-dimensional (straight line) collisions. For these, pay extra attention to direction: define one direction as positive and the other as negative, and be sure everybody gets the right sign.
- A firecracker in mid-air explodes...two children push off each other on roller skates...an atomic nucleus breaks apart during a radioactive decay: all of these are examples of *disintegration* problems. The initial momentum beforehand is zero, so the final momentum afterwards must also be zero.
- A spacecraft burns off momentum by colliding with air molecules as it descends...hail stones pummel the top of your car...a wet rag is thrown at and sticks to the wall: all of these are examples of *impulse* problems, where the change in momentum of one object and the reaction to the applied force are considered. What is important here is the rate: you need to come up with an average time  $\Delta t$  that the collision(s) last so that you can figure out the force  $\mathbf{F} = \Delta\mathbf{p}/\Delta t$ . Remember as well that if a particle has momentum  $\mathbf{p}$ , and it experiences an impulse that turns it around completely, with new momentum  $-\mathbf{p}$ , then the total change in momentum has magnitude  $2p$ . It is harder to turn something totally around than just to stop it!
- A car going south collides with a second car going east ... an inflatable ball is thrown into the flow of a waterfall ... a billiard ball strikes two others, sending all three off in new directions: these are all examples of two-dimensional (planar) collisions. For these, you get a break: the sum of all the momenta in the  $x$  direction have to remain unchanged before and after the collision — *independent* of any  $y$  momenta, and vice-versa. This is a similar concept to the one we used in projectile motion. Motions in different directions are independent of each other.
- Momenta vectors add just like any other vectors. Refer to the addition of vectors material in Chapter 1.

### Momentum Conservation Problem Set

1. You find yourself in the middle of a frozen lake. There is no friction between your feet and the ice of the lake. You need to get home for dinner. Which strategy will work best?
  - a. Press down harder with your shoes as you walk to shore.

- b. Take off your jacket. Then, throw it in the direction opposite to the shore.
- c. Wiggle your butt until you start to move in the direction of the shore.
- d. Call for help from the great Greek god Poseidon.

2. You jump off of the top of your house and hope to land on a wooden deck below. Consider the following possible outcomes:

- I. You hit the deck, but it isn't wood! A camouflaged trampoline slows you down over a time period of 0.2 seconds and sends you flying back up into the air.
- II. You hit the deck with your knees locked in a straight-legged position. The collision time is 0.01 seconds.
- III. You hit the deck and bend your legs, lengthening the collision time to 0.2 seconds.
- IV. You hit the deck, but it isn't wood! It is simply a piece of paper painted to look like a deck. Below is an infinite void and you continue to fall, forever.

- a. Which method will involve the greatest force acting on you?
- b. Which method will involve the least force acting on you?
- c. Which method will land you on the deck in the least pain?
- d. Which method involves the least impulse delivered to you?
- e. Which method involves the greatest impulse delivered to you?

3. You and your sister are riding skateboards side by side at the same speed. You are holding one end of a rope and she is holding the other. Assume there is no friction between the wheels and the ground. If your sister lets go of the rope, how does your speed change?

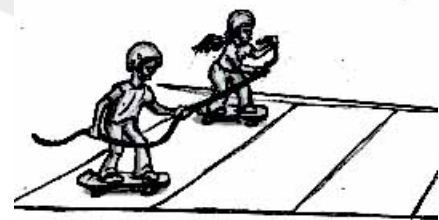

- a. It stays the same.
- b. It doubles.
- c. It reduces by half.

4. You and your sister are riding skateboards (see Problem 3), but now she is riding behind you. You are holding one end of a meter stick and she is holding the other. At an agreed time, you push back on the stick hard enough to get her to stop. What happens to your speed? Choose one. (For the purposes of this problem pretend you and your sister weigh the same amount.)

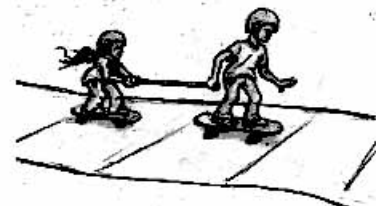

- a. It stays the same.
- b. It doubles.
- c. It reduces by half.

5. You punch the wall with your fist. Clearly your fist has momentum before it hits the wall. It is equally clear that after hitting the wall, your fist has no momentum. But momentum is always conserved! Explain.

6. An astronaut is using a drill to fix the gyroscopes on the Hubble telescope. Suddenly, she loses her footing and floats away from the telescope. What should she do to save herself?



7. You look up one morning and see that a 30 kg chunk of asbestos from your ceiling is falling on you! Would you be better off if the chunk hit you and stuck to your forehead, or if it hit you and bounced upward? Explain your answer.

8. A 5.00 kg firecracker explodes into two parts: one part has a mass of 3.00 kg and moves at a velocity of 25.0 m/s towards the west. The other part has a mass of 2.00 kg. What is the velocity of the second piece as a result of the explosion?

9. A firecracker lying on the ground explodes, breaking into two pieces. One piece has twice the mass of the other. What is the ratio of their speeds?

10. You throw your 6.0 kg skateboard down the street, giving it a speed of 4.0 m/s. Your friend, the Frog, jumps on your skateboard from rest as it passes by. Frog has a mass of 60 kg.

- What is the momentum of the skateboard before Frog jumps on it?
- Find Frog's speed after he jumps on the skateboard.
- What impulse did Frog deliver to the skateboard?
- If the impulse was delivered over 0.2 seconds, what was the average force imparted to the skateboard?
- What was the average force imparted to the Frog? Explain.

11. Two blocks collide on a frictionless surface, as shown. Afterwards, they have a combined mass of 10 kg and a speed of 2.5 m/s. Before the collision, one of the blocks was at rest. This block had a mass of 8.0 kg. What was the mass and initial speed of the second block?

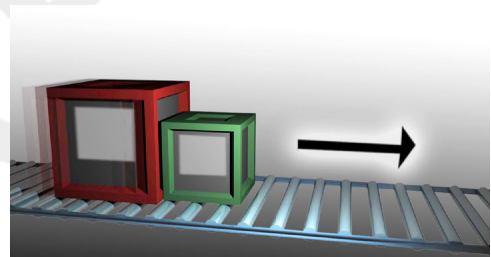

12. While driving in your pickup truck down Highway 280 between San Francisco and Palo Alto, an asteroid lands in your truck bed! Despite its 220 kg mass, the asteroid does not destroy your 1200 kg truck. In fact, it landed perfectly vertically. Before the asteroid hit, you were going 25 m/s. After it hit, how fast were you going?

13. A baseball player faces a 80.0m/s pitch. In a matter of .020 seconds he swings the bat, hitting a 50.0m/s line drive back at the pitcher. Calculate the force on the bat while in contact with the ball.

14. An astronaut is 100 m away from her spaceship doing repairs with a 10.0 kg wrench. The astronaut's total mass is 90.0 kg and the ship has a mass of  $1.00 \times 10^4$  kg.

If she throws the wrench in the opposite direction of the spaceship at 10.0 m/s how long would it take for her to reach the ship?

15. A place kicker applies an average force of 2400 N to a football of .040 kg. The force is applied at an angle of 20.0 degrees from the horizontal. Contact time is .010 sec.

- Find the velocity of the ball upon leaving the foot.
- Assuming no air resistance find the time to reach the goal posts 40.0 m away.
- The posts are 4.00 m high. Is the kick good? By how much?



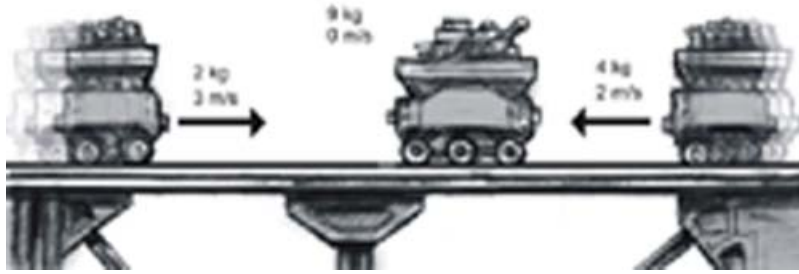

16. In the above picture, the carts are moving on a level, frictionless track. After the collision all three carts stick together. Determine the direction and speed of the combined carts after the collision. (Assume 3-significant digit accuracy.)

17. Your author's Italian cousin crashed into a tree. He was originally going 35 km/hr. Assume it took 0.4 seconds for the tree to bring him to a stop. The mass of the cousin and the car is 450 kg.

- What average force did he experience? Include a direction in your answer.
- What average force did the tree experience? Include a direction in your answer.
- Express this force in pounds.
- How many g's of acceleration did he experience?



18. The train engine and its four boxcars are coasting at 40 m/s. The engine train has mass of 5,500 kg and the boxcars have masses, from left to right, of 1,000 kg, 1,500 kg, 2,000 kg, and 3,000 kg. (For this problem, you may neglect the small external forces of friction and air resistance.)



- What happens to the speed of the train when it releases the last boxcar? (*Hint: Think before you blindly calculate.*)
- If the train can shoot boxcars backwards at 30 m/s *relative to the train's speed*, how many boxcars does the train need to shoot out in order to obtain a speed of 58.75 m/s?

19. Serena Williams volleys a tennis ball hit to her at 30 m/s. She blasts it back to the other court at 50 m/s. A standard tennis ball has mass of 0.057 kg. If Serena applied an average force of 500 N to the ball while it was in contact with the racket, how long did the contact last?



20. Zoran's spacecraft, with mass 12,000 kg, is traveling to space. The structure and capsule of the craft have a mass of 2,000 kg; the rest is fuel. The rocket shoots out 0.10 kg/s of fuel particles with a velocity of 700 m/s with respect to the craft.

- a. What is the acceleration of the rocket in the first second?
- b. What is the average acceleration of the rocket after the first ten minutes have passed?

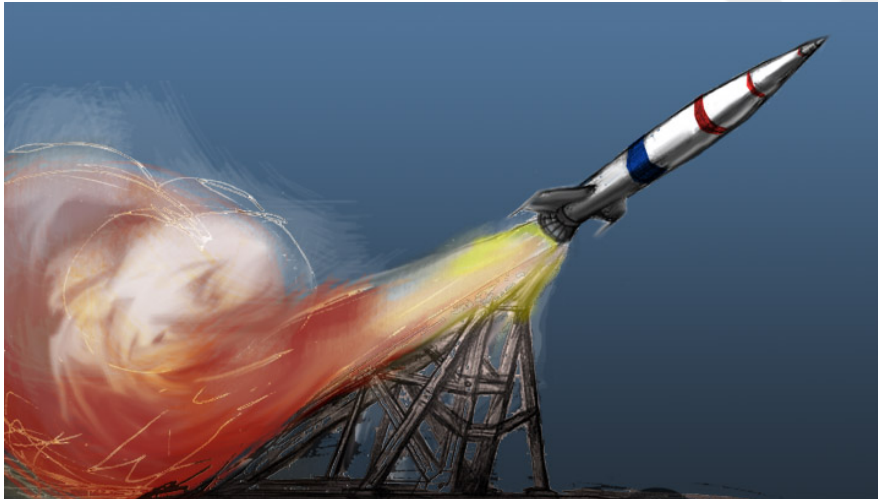

21. In Sacramento a 4000 kg SUV is traveling 30 m/s south on Truxel crashes into an empty school bus, 7000 kg traveling east on San Juan. The collision is perfectly inelastic.

- a. Find the velocity of the wreck just after collision
- b. Find the direction in which the wreck initially moves

22. A 3 kg ball is moving 2 m/s in the positive x-direction when it is struck dead center by a 2 kg ball moving in the positive y-direction. After collision the 3 kg ball moves at 1 m/s 30 degrees from the positive x-axis.

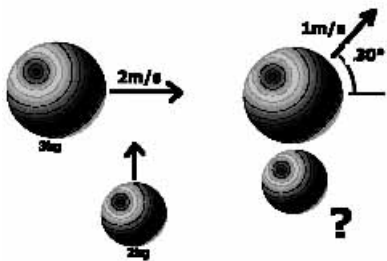

a. To 2-significant digit accuracy fill out the following table:

	3 kg ball $p_x$	3 kg ball $p_y$	2 kg ball $p_x$	2 kg ball $p_y$
Momentum before				
Momentum after collision				

b. Find the velocity and direction of the 2 kg ball.

c. Use the table to prove momentum is conserved.

d. Prove that kinetic energy is not conserved.

23. Students are doing an experiment on the lab table. A steel ball is rolled down a small ramp and allowed to hit the floor. Its impact point is carefully marked. Next a second ball of the same mass is put upon a set screw and a collision takes place such that both balls go off at an angle and hit the floor. All measurements are taken with a meter stick on the floor with a co-ordinate system such that just below the impact point is the origin. The following data is collected:

(1) no collision: 41.2 cm

(2) target ball: 37.3 cm in the direction of motion and 14.1 cm perpendicular to the direction of motion

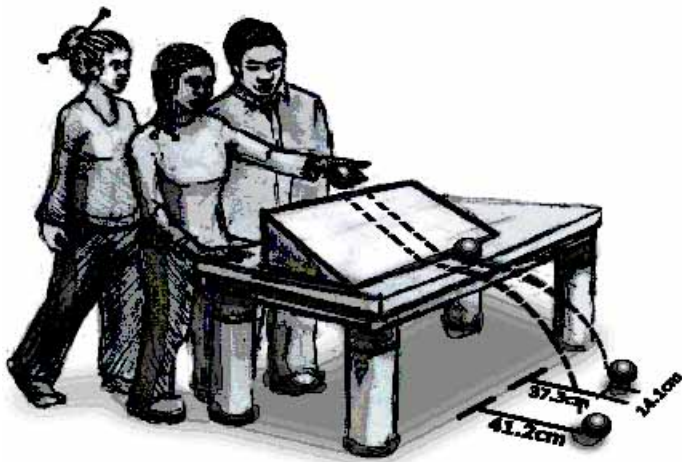

a. From this data predict the impact position of the other ball

b. One of the lab groups declares that the data on the floor alone demonstrate to a 2% accuracy that the collision was elastic. Show their reasoning.

c. Another lab group says they can't make that determination without knowing the velocity the balls have on impact. They ask for a timer. The instructor says you don't need one; use your meter stick. Explain.

d. Design an experiment to prove momentum conservation with balls of different masses, giving apparatus, procedure and design. Give some sample numbers.

DRAFT

# 9. Energy and Force

AUTHOR: James H. Dann, Ph.D., James J. Dann SOURCE: The People's Physics Book LICENSE: CCSA



## The Big Idea

When any two bodies in the universe interact, they can exchange energy, momentum, or both. The law of *conservation of energy* states that in any closed system (including the universe) the total quantity of energy remains fixed. Energy is transferred from one form to another, but none is lost or gained. If energy is put into a system from the outside or vice versa it is often in the form of *work*, which is a transfer of energy between bodies. (Calculated as force times displacement, provided the force is in the direction of displacement.)

The law of *conservation of momentum* states that in any closed system (including the universe) the total quantity of momentum is invariant. Momentum can be transferred from one body to another, but none is lost or gained. If a system has its momentum changed from the outside it is caused by an *impulse*, which transfers momentum from one body to another. (Calculated as force multiplied by time of impact.)

## Key Equations

$J = N \cdot m = \text{kg} \cdot \text{m}^2/\text{s}^2$	Energy is measured in joules
$K = \frac{1}{2} mv^2$	Kinetic energy (measured in Joules, J)
$U_g = mgh$	Gravitational potential energy (J)
$U_{sp} = \frac{1}{2}k(\Delta x)^2$	Spring potential energy (J)
$W = F_x \cdot \Delta x$	Work given to or taken away from a system by a force (J)
$\sum E_{\text{initial}} = \sum E_{\text{final}}$	Energy is conserved; the total energy does not change from an initial configuration and the final configuration
$P = \Delta E/\Delta t$	Power delivered to or from a system is the rate of change of energy in a certain time (measured in Watts; $1 \text{ W} = 1 \text{ J/s}$ )
$J = \Delta p = F\Delta t$	Impulse is the change in momentum of a system (kg-m/s).
$\mathbf{p}_{\text{tot,initial}} = \mathbf{p}_{\text{tot,final}}$	Momentum is a vector, so all components are conserved.

## Key Concepts

- Impulse is how momentum is transferred from one system to another. You can always determine the impulse by finding the changes in momentum, which are done by forces acting over a period of time. If you graph force vs. time of impact the area under the curve is the impulse.
- Work is simply how much energy was transferred from one system to another system. You can always find the work done *on* an object (or done *by* an object) by determining how much energy has been transferred into or out of the object through forces. If you graph force vs. distance, the area under the curve is work. (The semantics take some getting used to: if *you* do work on *me*, then you have lost energy, and I have gained energy.)

### Key Applications

- When working a problem that asks for *height* or *speed*, energy conservation is almost always the easiest approach.
- Potential energy of gravity,  $U_g$ , is always measured with respect to some arbitrary 'zero' height defined to be where the gravitational potential energy is zero. You can set this height equal to zero at any altitude you like. Be consistent with your choice throughout the problem. Often it is easiest to set it to zero at the lowest point in the problem.
- When using the equation  $E_{\text{tot,initial}} = E_{\text{tot,final}}$  to solve a problem, it is important to know which side of the equation the kinetic and potential energy, work, heat, etc., go on. To figure this out, think about what kind of energy the person or object had in the beginning (*initial*) and what kind it had in the end (*final*).
- Some problems require you to use both energy conservation *and* momentum conservation. Remember, in every collision, momentum is conserved. Kinetic energy, on the other hand, is not always conserved, since some kinetic energy may be lost to heat.
- If a system involves no energy losses due to heat or sound, no change in potential energy and no work is done by anybody to anybody else, then kinetic energy is conserved. Collisions where this occurs are called *elastic*. In elastic collisions, both kinetic energy and momentum are conserved. In *inelastic* collisions kinetic energy is not conserved; only momentum is conserved.
- Sometimes energy is "lost" when crushing an object. For instance, if you throw silly putty against a wall, much of the energy goes into flattening the silly putty (changing intermolecular bonds). Treat this as lost energy, similar to sound, chemical changes, or heat. In an inelastic collision, things stick, energy is lost, and so kinetic energy is not conserved.
- When calculating work, use the component of the force that is in the same direction as the motion. Components of force perpendicular to the direction of the motion don't do work. (Note that centripetal forces never do work, since they are always perpendicular to the direction of motion.)
- When calculating impulse the time to use is when the force is in contact with the body.

### Energy and Force Problem Set

1. At 8:00 AM, a bomb exploded in mid-air. Which of the following is true of the pieces of the bomb after explosion? (Select all that apply.)
  - a. The vector sum of the momenta of all the pieces is zero.
  - b. The total kinetic energy of all the pieces is zero.
  - c. The chemical potential energy of the bomb has been converted entirely to the kinetic energy of the pieces.
  - d. Energy is lost from the system to sound, heat, and a pressure wave.

2. A rock with mass  $m$  is dropped from a cliff of height  $h$ . What is its speed when it gets to the bottom of the cliff?

a.  $\sqrt{mg}$

b.  $\sqrt{\frac{2g}{h}}$

c.  $\sqrt{2gh}$

d.  $gh$

e. None of the above

3. Two cats, Felix and Meekwad, collide. Felix has a mass of 2 kg and an initial velocity of 10m/s to the west. Meekwad has a mass of 1 kg and is initially at rest. After the collision, Felix has a velocity of 4m/s to the west and Meekwad has a velocity of 12 m/s to the west. Verify that momentum was conserved. Then, determine the kinetic energies of the system before and after the collision. What happened?! (All numbers are exact.)

4. You are at rest on your bicycle at the top of a hill that is 20 m tall. You start rolling down the hill. At the bottom of the hill you have a speed of 22 m/s. Your mass is 80 kg. Assuming no energy is gained by or lost to any other source, which of the following must be true?

- a. The wind must be doing work on you.
- b. You must be doing work on the wind.
- c. No work has been done on either you or the wind.
- d. Not enough information to choose from the first three.

5. A snowboarder, starting at rest at the top of a mountain, flies down the slope, goes off a jump and crashes through a second-story window at the ski lodge. Retell this story, but describe it using the language of energy. Be sure to describe both how and when the skier gained and lost energy during her journey.

6. An airplane with mass 200,000 kg is traveling with a speed of 268 m/s.

a. What is the kinetic energy of the plane at this speed?

A wind picks up, which causes the plane to lose  $1.20 \times 10^8$  J per second.

b. How fast is the plane going after 25.0 seconds?

7. A roller coaster begins at rest 120 m above the ground, as shown. Assume no friction from the wheels and air, and that no energy is lost to heat, sound, and so on. The radius of the loop is 40 m.

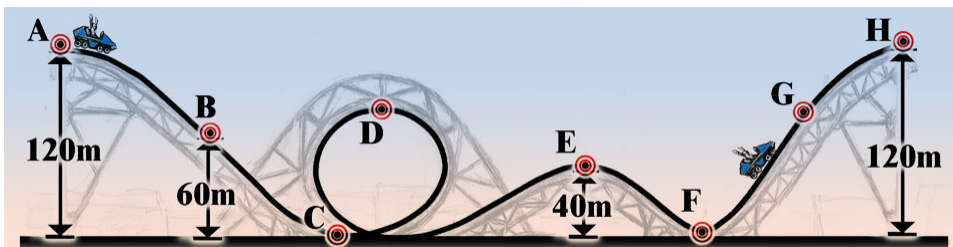

a. Find the speed of the roller coaster at points B, C, D, E, F, and H.



b. Assume that 25% of the initial potential energy of the coaster is lost due to heat, sound, and air resistance along its route. How far short of point H will the coaster stop?

c. Does the coaster actually make it through the loop without falling? (Hint: You might review the material from Chapter 6 to answer this part.)

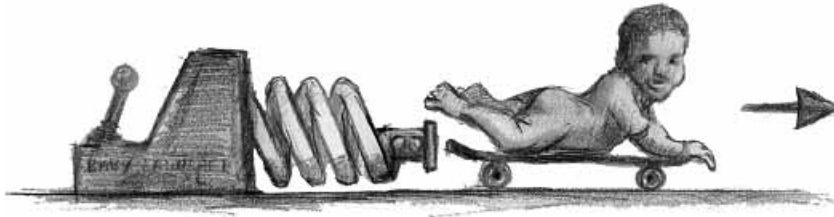

8. In the picture above, a 9.0 kg baby on a skateboard is about to be launched horizontally. The spring constant is 300 N/m and the spring is compressed 0.4 m. For the following questions, ignore the small energy loss due to the friction in the wheels of the skateboard and the rotational energy used up to make the wheels spin.

a. What is the speed of the baby after the spring has reached its uncompressed length?

b. After being launched, the baby encounters a hill 7 m high. Will the baby make it to the top? If so, what is his speed at the top? If not, how high does he make it?

c. Are you finally convinced that your authors have lost their minds? Look at that picture!

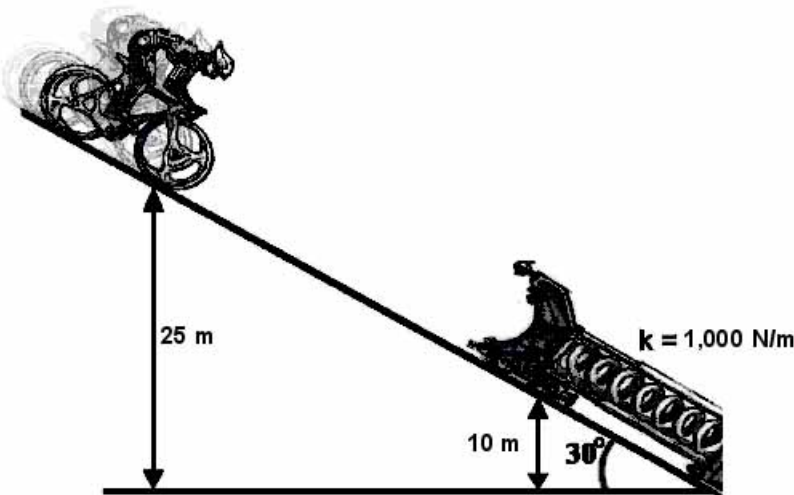

9. When the biker is at the top of the ramp shown above, he has a speed of 10 m/s and is at a height of 25m. The bike and person have a total mass of 100 kg. He speeds into the contraption at the end of the ramp, which slows him to a stop.

a. What is his initial total energy? (Hint: Set  $U_g = 0$  at the very bottom of the ramp.)

b. What is the length of the spring when it is maximally compressed by the biker? (Hint: The spring does *not* compress all the way to the ground so there is still some gravitational potential energy. It will help to draw some triangles.)

10. An elevator in an old apartment building in Switzerland has four huge springs at the bottom of the shaft to cushion its fall in case the cable breaks. The springs have an uncompressed height of about 1 meter. Estimate the spring constant necessary to stop this elevator, following these steps:



a. First, guesstimate the mass of the elevator with a few passengers inside.

b. Now, estimate the height of a five-story building.

c. Lastly, use conservation of energy to estimate the spring constant.

11. You are driving your buddy to class in a car of mass 900 kg at a speed of 50 m/s. You and your passenger each have 80 kg of mass. Suddenly, a deer runs out in front of your car. The coefficient of friction between the tires and the freeway cement is  $\mu_k = 0.9$ . In addition there is an average force of friction of 6,000 N exerted by air resistance, friction of the wheels and axles, etc. in the time it takes the car to stop.

a. What is your stopping distance if you skid to a stop?

b. What is your stopping distance if you roll to a stop (*i.e.*, if the brakes don't lock)?

12. You are skiing down a hill. You start at rest at a height 120 m above the bottom. The slope has a  $10.0^\circ$  grade. Assume the total mass of skier and equipment is 75.0 kg.



a. Ignore all energy losses due to friction. What is your speed at the bottom?

b. If, however, you just make it to the bottom with zero speed what would be the average force of friction, including air resistance?

13. Two horrific contraptions on frictionless wheels are compressing a spring ( $k = 400 \text{ N/m}$ ) by 0.5 m compared to its uncompressed (equilibrium) length. Each of the 500 kg vehicles is stationary and they are connected by a string. The string is cut! Find the speeds of the masses once they lose contact with the spring.

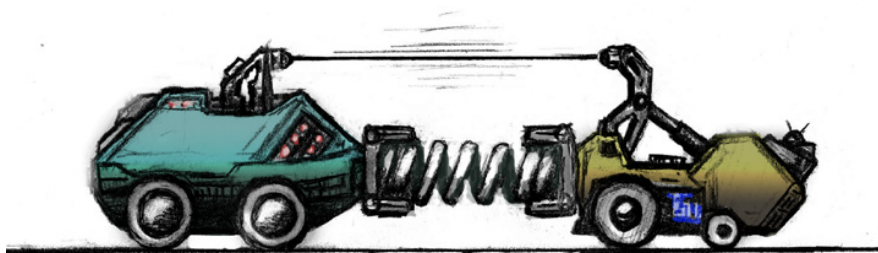

14. You slide down a hill on top of a big ice block as shown in the diagram. Your speed at the top of the hill is zero. The coefficient of kinetic friction on the slide down the hill is zero ( $\mu_k = 0$ ). The coefficient of kinetic friction on the level part just beneath the hill is 0.1 ( $\mu_k = 0.1$ ).

a. What is your speed just as you reach the bottom of the hill?

b. How far will you slide before you come to a stop?

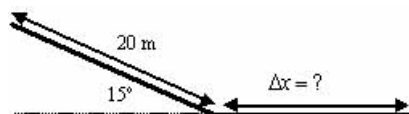

15. A 70 kg woman falls from a height of 2.0 m and lands on a springy mattress.

a. If the springs compress by 0.5 m, what is the spring constant of the mattress?

b. If no energy is lost from the system, what height will she bounce back up to?

16. Marciel is at rest on his skateboard (total mass 50 kg) until he catches a ball traveling with a speed of 50 m/s. The baseball has a mass of 2 kg. What percent of the original kinetic energy is transferred into heat, sound, deformation of the baseball, and other non-mechanical forms when the collision occurs?



17. You throw a 0.5 kg lump of clay with a speed of 5 m/s at a 15 kg bowling ball hanging from a vertical rope. The bowling ball swings up to a height of 0.01 m compared to its initial height. Was this an elastic collision? Justify your answer.

18. The 20 g bullet shown below is traveling to the right with a speed of 20 m/s. A 1.0 kg block is hanging from the ceiling from a rope 2.0 m in length.

a. What is the maximum height that the bullet-block system will reach, if the bullet embeds itself in the block?

b. What is the maximum angle the rope makes with the vertical after the collision?



19. You are playing pool and you hit the cue ball with a speed of 2 m/s at the 8-ball (which is stationary). Assume an elastic collision and that both balls are the same mass. Find the speed and direction of both balls after the collision, assuming neither flies off at any angle.

20. A 0.045 kg golf ball with a speed of 42.0 m/s collides elastically head-on with a 0.17 kg pool ball at rest. Find the speed and direction of both balls after the collision.

21. Ball A is traveling along a flat table with a speed of 5.0 m/s, as shown below. Ball B, which has the same mass, is initially at rest, but is knocked off the table in an elastic collision with Ball A. Find the horizontal distance that Ball B travels before hitting the floor.

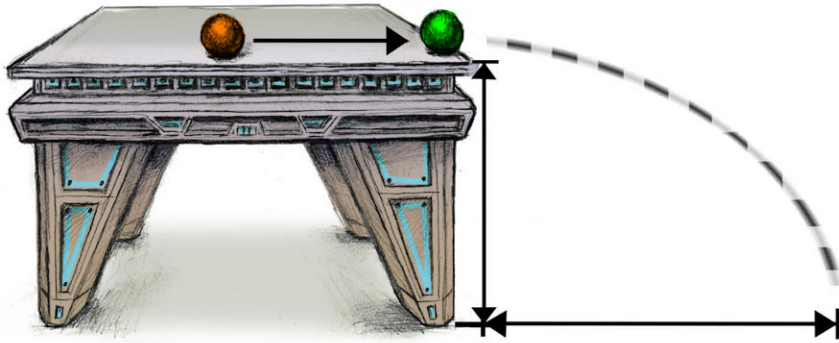

22. Manrico (80.0 kg) and Leonora (60.0 kg) are figure skaters. They are moving toward each other. Manrico's speed is 2.00 m/s; Leonora's speed is 4.00 m/s. When they meet, Leonora flies into Manrico's arms.

- With what speed does the entwined couple move?
- In which direction are they moving?
- How much kinetic energy is lost in the collision?

23. Aida slides down a 20.0 m high hill on a frictionless sled (combined mass 40.0 kg). At the bottom of the hill, she collides with Radames on his sled (combined mass 50.0 kg). The two children cling together and move along a horizontal plane that has a coefficient of kinetic friction of 0.10.

- What was Aida's speed before the collision?
- What was the combined speed immediately after collision?
- How far along the level plane do they move before stopping?

24. A pile driver lifts a 500 kg mass a vertical distance of 20 m in 1.1 sec. It uses 225 kW of supplied power to do this.

- How much power was used in actually lifting the mass?
- What is the efficiency of the machine? (This is the ratio of power used to power supplied.)
- The mass is dropped on a pile and falls 20 m. If it loses 40,000 J on the way down to the ground due to air resistance, what is its speed when it hits the pile?

25. Investigating a traffic collision, you determine that a fast-moving car (mass 600 kg) hit and stuck to a second car (mass 800 kg), which was initially at rest. The two cars slid a distance of 30.0 m over rough pavement with a coefficient of friction of 0.60 before coming to a halt. What was the speed of the first car? Was the driver above the posted 60 MPH speed limit?

26. Force is applied in the direction of motion to a 15.0 kg cart on a frictionless surface. The motion is along a straight line and when  $t = 0$ , then  $x = 0$  and  $v = 0$ . (The displacement and velocity of the cart are initially zero.) Look at the following graph:

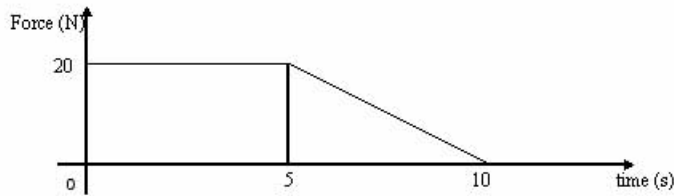

- What is the change in momentum during the first 5 sec?
- What is the change in velocity during the first 10 sec?
- What is the acceleration at 4 sec?
- What is the total work done on the cart by the force from 0 – 10 sec?
- What is the displacement after 5 sec?

27. Force is applied in the direction of motion to a 4.00 kg cart on a frictionless surface. The motion is along a straight line and when  $t = 0$ ,  $v = 0$  and  $x = 0$ . look at the following graph:

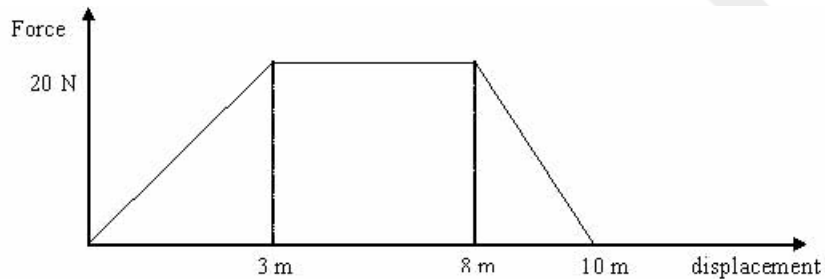

- What is the acceleration of the cart when the displacement is 4 m?
- What work was done on the cart between  $x = 3$  m and  $x = 8$  m?
- What is the total work done on the cart between 0 -10 m?
- What is the speed of the cart at  $x = 10$  m?
- What is the impulse given the cart by the force from 1 – 10 m?
- What is the speed at  $x = 8$  m?
- How much time elapsed from when the cart was at  $x = 8$  to when it got to  $x = 10$  m?

28. You are to design an experiment to measure the average force an archer exerts on the bow as she pulls it back prior to releasing the arrow. The mass of the arrow is known. The only lab equipment you can use is a meter stick.

- Give the procedure of the experiment and include a diagram with the quantities to be measured shown.
- Give sample calculations using realistic numbers.
- What is the single most important inherent error in the experiment?

d. Explain if this error would tend to make the force that it measured greater or lesser than the actual force and why.

29. Molly eats a 500 kcal ( $2.09 \times 10^6$  J) power bar before the big pole vault. The bar's energy content comes from changing chemical bonds from a high to a low state and expelling gases. However, 25.0% of the bar's energy is lost expelling gases and 60.0% is needed by the body for various biological functions.

a. How much energy is available to Molly for the run?

b. Energy losses due to air resistance and friction on the run are 200,000 J, Molly's increased heart rate and blood pressure use 55,000 J of the available energy during the run. What top speed can the 50.0 kg Molly expect to attain?

c. The kinetic energy is transferred to the pole, which is "compressed" like a spring of  $k = 2720$  N/m; air resistance energy loss on the way up is 300 J, and as she crosses the bar she has a horizontal speed of 2.00 m/s. If Molly rises to a height equal to the expansion of the pole what is that height she reaches?

d. On the way down she encounters another 300 J of air resistance. How much heat in the end is given up when she hits the dirt and comes to a stop?



30. A new fun foam target on wheels for archery students has been invented. The arrow of mass,  $m$ , and speed,  $v_0$ , goes through the target and emerges at the other end with reduced speed,  $v_0/2$ . The mass of the target is  $7m$ . Ignore friction and air resistance.

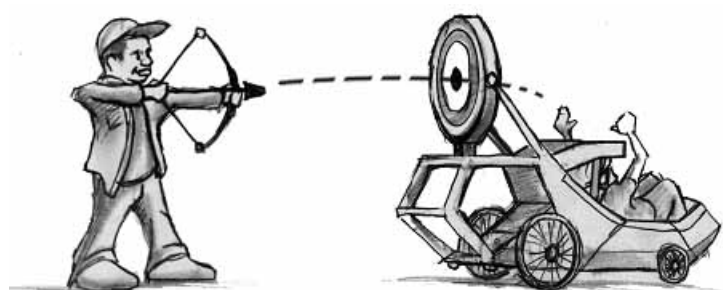

a. What is the final speed of the target?

b. What is the kinetic energy of the arrow after it leaves the target?

c. What is the final kinetic energy of the target?

d. What percent of the initial energy of the arrow was lost in the shooting?

# 10. Rotational Motion

AUTHOR: James H. Dann, Ph.D., James J. Dann SOURCE: The People's Physics Book LICENSE: CCSA



## The Big Idea

The third conservation law is *conservation of angular momentum*. This can be roughly understood as spin, more accurately it is rotational velocity multiplied by rotational inertia. In any closed system (including the universe) the quantity of angular momentum is fixed. Angular momentum can be transferred from one body to another, but cannot be lost or gained. If a system has its angular momentum changed from the outside it is caused by a torque multiplied by time of impact. Torque is a force applied at a distance from the center of rotation.

## Key Concepts

- To determine the *rotation axis*, wrap your right hand fingers in the direction of rotation and your thumb points along the axis (see figure).
- When something rotates in a circle, it moves through a *position angle*  $\theta$  that runs from 0 to  $2\pi$  radians and starts over again at 0. The physical distance  $d$  it moves is called the *path length*. If the radius of the circle is larger, the distance traveled is larger.
- How quickly the position angle  $\theta$  changes with time determines the angular velocity  $\omega$ . The direction of angular velocity is either clockwise or counterclockwise. How quickly the angular velocity changes determines the angular acceleration  $\alpha$ .
- The linear velocity  $\mathbf{v}$  and linear acceleration also depend on the radius of rotation, which is called the *moment arm*  $r$  (See figure below.)
- If something is spinning, it moves more quickly if it is farther from the center of rotation. For instance, people at the Earth's equator are physically moving faster than people at northern latitudes, even though their day is still 24 hours long – this is because they have a greater circumference to travel in the same amount of time.

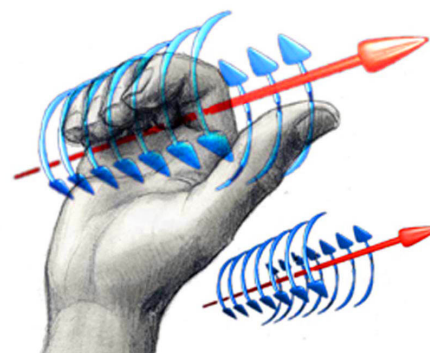



- There are analogies to the “Big Three” equations that work for rotational motion just like they work for linear motion.
- As before once you have the acceleration you can predict the motion. Just as linear accelerations are caused by forces, angular accelerations are caused by *torques*.
- **Torques** produce angular accelerations, but just as masses resist acceleration (due to inertia), there is an inertia that opposes angular acceleration. The measure of this inertial resistance depends on the mass, but more importantly on the distribution of the mass in the body. **The moment of inertia,  $I$ , is the rotational version of mass.** Values for the moment of inertia of common objects are given in problem 2. Torques have only two directions: those that produce clockwise (CW) and those that produce counter-clockwise (CCW) rotations. The angular acceleration or change in  $\omega$  would be in the direction of the torque.

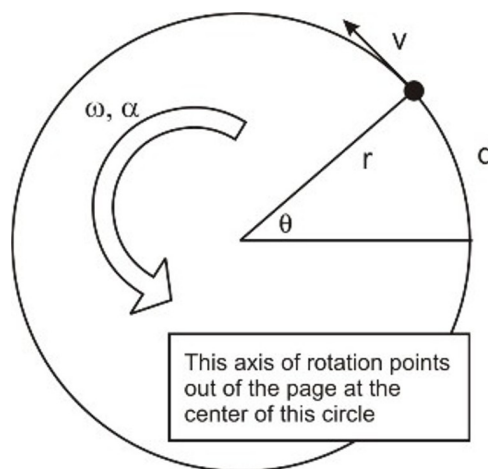

• Imagine spinning a fairly heavy disk. To make it spin, you don't push *towards* the disk center— that will just move it in a straight line. To spin it, you need to push along the side, much like when you spin a basketball. Thus, the *torque* you exert on a disk to make it accelerate depends only on the component of the force perpendicular to the radius of rotation:  $\tau = rF_{\perp}$ .

- Many separate torques can be applied to an object. The angular acceleration produced is  $\alpha = \tau_{\text{net}} / I$ .
- The *angular momentum* of a spinning object is  $L = I\omega$ . Torques produce a change in angular momentum with time:  $\tau = \Delta L / \Delta t$
- Spinning objects have a kinetic energy, given by  $K = \frac{1}{2}I\omega^2$ .

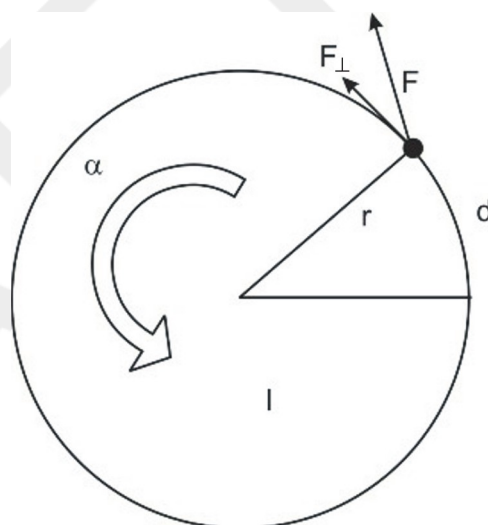

### Table of Analogies

<i>Linear motion</i>	<i>Rotational motion</i>	<i>Rotational unit</i>
$x$	$\theta$	radians
$v$	$\omega$	radians/second
$a$	$\alpha$	radians/second <sup>2</sup>
$F$	$\tau$	Meter-Newton
$m$	$I$	kg·meters <sup>2</sup>
$a = F_{\text{net}} / m$	$\alpha = \tau_{\text{net}} / I$	Radians/sec <sup>2</sup>
$p = mv$	$L = I\omega$	kg·meters <sup>2</sup> /sec
$F = \Delta p / \Delta t$	$\tau = \Delta L / \Delta t$	Meter-Newton
$K = \frac{1}{2}mv^2$	$K = \frac{1}{2}I\omega^2$	Joules

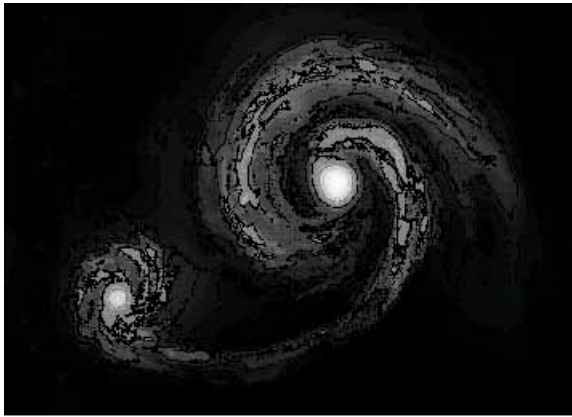

**Key Equations** (These are simpler than they look: many are familiar equations in new “rotational” language!)

$d = r\theta$	the path length along an arc is equal to the radius of the arc times the angle through which the arc passes
$v = r\omega (\omega = (\Delta\theta/\Delta t))$	the linear velocity of an object in rotational motion is the radius of rotation times the angular velocity
$a = r\alpha (\alpha = \Delta\omega/\Delta t)$	the linear acceleration of an object in rotational motion is the radius of rotation times the angular acceleration; this is <i>in</i> the direction of motion
$a_c = -mv^2/r = -r\omega^2$	the centripetal acceleration of an object in rotational motion depends on the radius of rotation and the angular speed; the sign reminds us that it points inward towards the center of the circle; this is just  $mv^2/r!$
$\omega = 2\pi/T = 2\pi f$	angular velocity and period are simply related
$\theta(t) = \theta_0 + \omega_0 t + 1/2\alpha t^2$	the ‘Big Three’ equations work for rotational motion too!
$\omega(t) = \omega_0 + \alpha t$	
$\omega^2 = \omega_0^2 + 2\alpha (\Delta\theta)$	
$\alpha = \tau_{net}/I$	angular accelerations are produced by net torques, with inertia opposing acceleration; this is the rotational analog of  $a = F_{net}/m$
$\tau_{net} = \sum \tau_i = I\alpha$	the net torque is the vector sum of all the torques acting on the object. When adding torques it is necessary to subtract CW from CCW torques.
$\tau = \mathbf{r} \times \mathbf{F} = r_{\perp}F = rF_{\perp}$	individual torques are determined by multiplying the force applied by the <i>perpendicular</i> component of the moment arm
$L = I\omega$	angular momentum is the product of moment of inertia and angular velocity.



$\tau = \Delta L / \Delta t$	torques produce changes in angular momentum; this is the rotational analog of  $F = \Delta p / \Delta t$
$K = 1/2 I \omega^2$	angular motion counts for kinetic energy as well!

### Rotational Motion Problem Set

1. The wood plug, shown below, has a lower moment of inertia than the steel plug because it has a lower mass.



a. Which of these plugs would be easier to spin on its axis? Explain.

Even though they have the same mass, the plug on the right has a higher moment of inertia ( $I$ ), than the plug on the left, since the mass is distributed at greater radius.

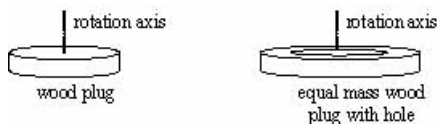

b. Which of the plugs would have a greater angular momentum if they were spinning with the same angular velocity? Explain.

2. Here is a table of some moments of inertia of commonly found objects:

<i>Object</i>	<i>Drawing</i>	<i>Moment of Inertia</i>
Disk (rotated about center)		$\frac{1}{2}MR^2$
Ring (rotated about center)		$MR^2$
Rod or plank (rotated about center)		$\frac{1}{12}ML^2$
Rod or plank (rotated about end)		$\frac{1}{3}ML^2$
Sphere		$\frac{2}{5}MR^2$
Satellite		$MR^2$

- Calculate the moment of inertia of the Earth about its spin axis.
- Calculate the moment of inertia of the Earth as it revolves around the Sun.
- Calculate the moment of inertia of a hula hoop with mass 2 kg and radius 0.5 m.

d. Calculate the moment of inertia of a rod 0.75 m in length and mass 1.5 kg rotating about one end.

e. Repeat d., but calculate the moment of inertia about the center of the rod.

3. Imagine standing on the North Pole of the Earth as it spins. You would barely notice it, but you would turn all the way around over 24 hours, without covering any real distance. Compare this to people standing on the equator: they go all the way around the entire circumference of the Earth every 24 hours! Decide whether the following statements are TRUE or FALSE. Then, explain your thinking.

a. The person at the North Pole and the person at the equator rotate by  $2\pi$  radians in 86,400 seconds.

b. The angular velocity of the person at the equator is  $2\pi/86400$  radians per second.

c. Our angular velocity in San Francisco is  $2\pi/86400$  radians per second.

d. Every point on the Earth travels the same distance every day.

e. Every point on the Earth rotates through the same angle every day.

f. The angular momentum of the Earth is the same each day.

g. The angular momentum of the Earth is  $2/5MR^2\omega$ .

h. The rotational kinetic energy of the Earth is  $1/5MR^2\omega^2$ .

i. The *orbital* kinetic energy of the Earth is  $1/2MR^2\omega^2$ , where R refers to the distance from the Earth to the Sun.

4. You spin up some pizza dough from rest with an angular acceleration of  $5 \text{ rad/s}^2$ .

a. How many radians has the pizza dough spun through in the first 10 seconds?

b. How many times has the pizza dough spun around in this time?

c. What is its angular velocity after 5 seconds?

d. What is providing the torque that allows the angular acceleration to occur?

e. Calculate the moment of inertia of a flat disk of pizza dough with mass 1.5 kg and radius 0.6 m.

f. Calculate the rotational kinetic energy of your pizza dough at  $t = 5 \text{ s}$  and  $t = 10 \text{ s}$ .

5. Your bike brakes went out! You put your feet on the wheel to slow it down. The rotational kinetic energy of the wheel begins to decrease. Where is this energy going?

6. Consider hitting someone with a Wiffle ball bat. Will it hurt them more if you grab the end or the middle of the bat when you swing it? Explain your thinking, but do so using the vocabulary of *moment of inertia* (treat the bat as a rod), *angular momentum* (imagine the bat swings down in a semi-circle), and *torque* (in this case, torques caused by the contact forces the other person's head and the bat are exerting on each other).

7. Why does the Earth keep going around the Sun? Shouldn't we be spiraling farther and farther downward towards the Sun, eventually falling into it? Why do low-Earth satellites eventually spiral down and burn up in the atmosphere, while the Moon never will?

8. If most of the mass of the Earth were concentrated at the core (say, in a ball of dense iron), would the moment of inertia of the Earth be higher or lower than it is now? (Assume the total mass stays the same.)

9. Two spheres of the same mass are spinning in your garage. The first is 10 cm in diameter and made of iron. The second is 20 cm in diameter but is a thin plastic sphere filled with air. Which is harder to slow down? Why? (And why are two spheres spinning in your garage?)

10. A game of tug-o-war is played ... but with a twist (ha!). Each team has its own rope attached to a merry-go-round. One team pulls clockwise, the other counterclockwise. Each pulls at a different point and with a different force, as shown.

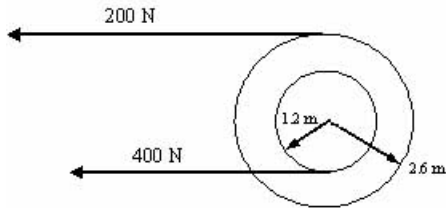

- Who wins?
- By how much? That is, what is the net torque?
- Assume that the merry-go-round is weighted down with a large pile of steel plates. It is so massive that it has a moment of inertia of  $2000 \text{ kg}\cdot\text{m}^2$ . What is its angular acceleration?
- How long will it take the merry-go-round to spin around once completely?

11. You have two coins; one is a standard U.S. quarter, and the other is a coin of equal mass and size, but with a hole cut out of the center.

- Which coin has a higher moment of inertia?
- Which coin would have the greater angular momentum if they are both spun at the same angular velocity?

12. A wooden plank is balanced on a pivot, as shown below. Weights are placed at various places on the plank.

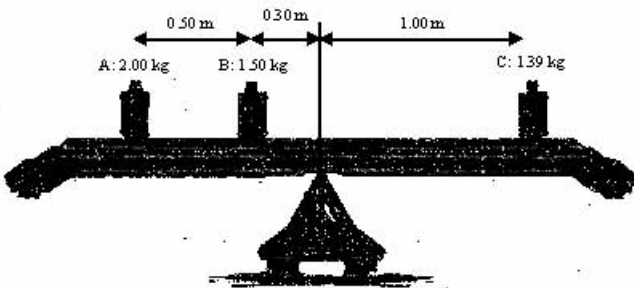

Consider the torque on the plank caused by weight A.

- What force, precisely, is responsible for this torque?
- What is the magnitude (value) of this force, in Newtons?
- What is the moment arm of the torque produced by weight A?
- What is the magnitude of this torque, in  $\text{N}\cdot\text{m}$ ?
- Repeat parts (a – d) for weights B and C.

f. Calculate the net torque. Is the plank balanced? Explain.

13. A star is rotating with a period of 10.0 days. It collapses with no loss in mass to a white dwarf with a radius of .001 of its original radius.

a. What is its initial angular velocity?

b. What is its angular velocity after collapse?

14. For a ball rolling without slipping with a radius of 0.10 m, a moment of inertia of  $25.0 \text{ kg}\cdot\text{m}^2$ , and a linear velocity of 10.0 m/s calculate the following:

a. The angular velocity.

b. The rotational kinetic energy.

c. The angular momentum.

d. The torque needed to double its linear velocity in 0.2 sec.

15. A merry-go-round consists of a uniform solid disc of 225 kg and a radius of 6.0 m. A single 80 kg person stands on the edge when it is coasting at 0.20 revolutions /sec. How fast would the device be rotating after the person has walked 3.5 m toward the center. (The moments of inertia of compound objects add.)

16. In the figure we have a horizontal beam of length,  $L$ , pivoted on one end and supporting 2000 N on the other. Find the tension in the supporting cable, which is at the same point at the weight and is at an angle of 30 degrees to the vertical. Ignore the weight of the beam.

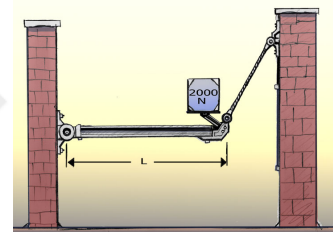

17. Two painters are on the fourth floor of a Victorian house on a scaffold, which weighs 400 N. The scaffold is 3.00 m long, supported by two ropes, each located 0.20 m from the end of the scaffold. The first painter of mass 75kg is standing at the center; the second of mass, 65.0 kg, is standing 1.00 m from one end.

a. Draw a free body diagram, showing all forces and all torques. (Pick one of the ropes as a pivot point.)

b. Calculate the tension in the two ropes.

c. Calculate the moment of inertia for rotation around the pivot point, which is supported by the rope with the least tension. (This will be a compound moment of inertia made of three components.)

d. Calculate the instantaneous angular acceleration assuming the rope of greatest tension breaks.

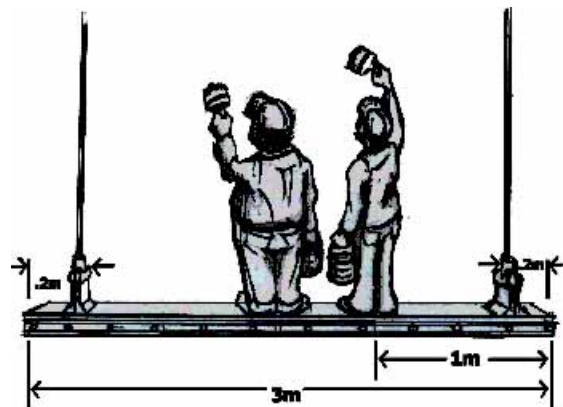

18. A horizontal 60 N beam, 1.4 m in length has a 100 N weight on the end. It is supported by a cable, which is connected to the horizontal beam at an angle of 37 degrees at 1.0 m from the wall. Further support is provided by the wall hinge, which exerts a force of unknown direction, but which has a vertical (friction) component and a horizontal (normal) component.

a. Find the tension in the cable.

b. Find the two components of the force on the hinge (magnitude and direction).

c. Find the coefficient of friction of wall and hinge.

19. On a busy intersection a 3.00 m beam of 150 N is connected to a post at an angle upwards of 20.0 degrees to the horizontal. From the beam straight down hang a 200 N sign 1.00 m from the post and a 500N signal light at the end of the beam. The beam is supported by a cable, which connects to the beam 2.00 m from the post at an angle of 45.0 degrees measured from the beam; also by the hinge to the post, which has horizontal and vertical components of unknown direction.

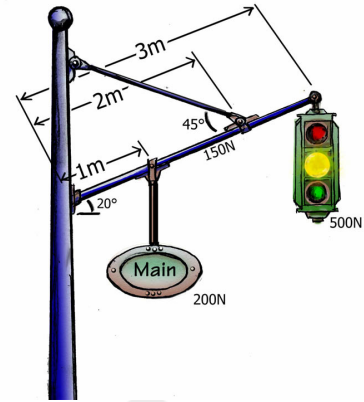

- Find the tension in the cable.
- Find the magnitude and direction of the horizontal and vertical forces on the hinge.
- Find the total moment of inertia around the hinge as the axis.
- Find the instantaneous angular acceleration of the beam if the cable were to break.

20. There is a uniform rod of mass 2.0 kg of length 2.0 m. It has a mass of 2.6 kg at one end. It is attached to the ceiling .40 m from the end with the mass. The string comes in at a 53 degree angle to the rod.

- Calculate the total torque on the rod.
- Determine its direction of rotation.
- Explain, but don't calculate, what happens to the angular acceleration as it rotates toward a vertical position.

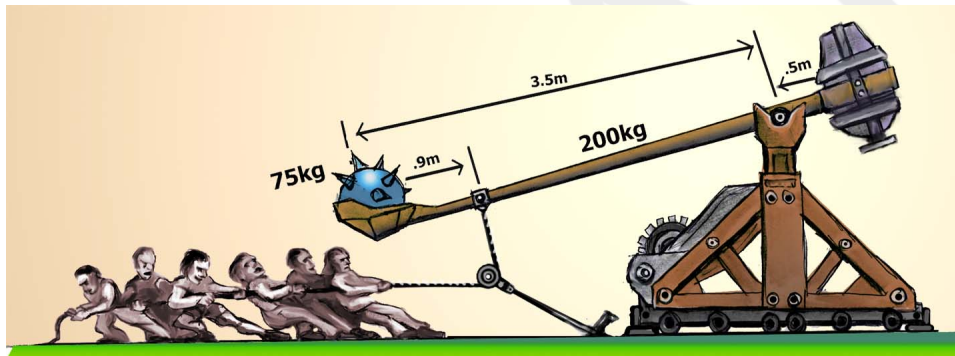

21. The medieval catapult consists of a 200 kg beam with a heavy ballast at one end and a projectile of 75.0 kg at the other end. The pivot is located 0.5 m from the ballast and a force with a downward component of 550 N is applied by prisoners to keep it steady until the commander gives the word to release it. The beam is 4.00 m long and the force is applied 0.900 m from the projectile end. Consider the situation when the beam is perfectly horizontal.

- Draw a free-body diagram labeling all torques.
- Find the mass of the ballast.
- Find the force on the horizontal support.
- How would the angular acceleration change as the beam moves from the horizontal to the vertical position. (Give a qualitative explanation.)
- In order to maximize range at what angle should the projectile be released?
- What additional information and/or calculation would have to be done to determine the range of the projectile?

# 11. Simple Harmonic Motion

AUTHOR: James H. Dann, Ph.D., James J. Dann SOURCE: The People's Physics Book LICENSE: CCSA



## The Big Idea

The development of devices to measure time like a pendulum led to the analysis of *periodic motion*. Motion that *repeats itself in equal intervals of time* is called *harmonic motion*. When an object moves back and forth over the *same path* in harmonic motion it is said to be *oscillating*. If the amount of motion of an oscillating object (the distance the object travels) stays the same during the period of motion, it is called *simple harmonic motion* (SHM). A grandfather clock's pendulum and the quartz crystal in a modern watch are examples of SHM.

## Key Concepts

- The oscillating object does not lose any energy in SHM. Friction is assumed to be zero.
- In harmonic motion there is always a *restorative force*, which acts in the opposite direction. The restorative force changes during oscillation and depends on the position of the object. In a spring the force is the Hooke's Law force,  $-kx$ ; in a pendulum it is the component of gravity along the the path.
- Objects in simple harmonic motion do not obey the "Big Three" equations of motion because the acceleration is not constant. As a spring compresses, the force (and hence acceleration) increases. As a pendulum swings, the tangential component of the force of gravity changes. The equations of motion for SHM are given in the Key Equations section.
- The period,  $T$ , is the amount of time for the harmonic motion to repeat itself, or for the object to go one full cycle. In SHM,  $T$  is the time it takes the object to return to its exact starting point and starting direction.
- The frequency,  $f$ , is the number of cycles an object goes through in 1 second. Frequency is measured in Hertz (Hz).  $1 \text{ Hz} = 1 \text{ cycle per sec}$ .
- The amplitude,  $A$ , is the distance from the *equilibrium* (or center) *point* of motion to either its lowest or highest point (*end points*). The amplitude, therefore, is half of the total distance covered by the oscillating object. The amplitude can vary in harmonic motion, but is constant in SHM.
- The kinetic energy and the speed are at a maximum at the equilibrium point, but the potential energy and restorative force is zero there.

- At the *end points* the potential energy is at a maximum, while the kinetic energy and speed are zero. However at the end points the restorative force and acceleration are at a maximum.
- In SHM since energy is conserved, often, the most fruitful method of calculating position and velocity is to set the total energy equal to the sum of kinetic and potential energies. Similarly force and acceleration are best calculated by using  $\Sigma F = ma$ .

### Key Equations

$T = 1 / f$	Period and frequency are inversely related.
$T_{sp} = 2\pi \sqrt{\frac{L}{g}}$	The period of oscillation in seconds for a mass oscillating on a spring depends on the mass of the object on the spring and the spring constant.
$T_p = 2\pi \sqrt{\frac{m}{k}}$	The period of oscillation in seconds for a pendulum (i.e. a mass swinging on a string) swinging at small angles ( $\theta < 15^\circ$ ) with respect to the vertical depends on the length of the pendulum and the acceleration due to gravity.
$x(t) = x_0 + A \cos[2\pi f(t - t_0)]$	The equation for the position of an object in SHM.
$v(t) = -2\pi f A \sin[2\pi f(t - t_0)]$	The equation for the velocity of an object in SHM.

### Simple Harmonic Motion Problem Set

1. While treading water, you notice a buoy way out towards the horizon. The buoy is bobbing up and down in simple harmonic motion. You only see the buoy at the most upward part of its cycle. You see the buoy appear 10 times over the course of one minute.

- What is the force that is leading to simple harmonic motion?
- What is the period ( $T$ ) and frequency ( $f$ ) of its cycle? Use the proper units.

2. A rope can be considered as a spring with a very high spring constant  $k$ , so high, in fact, that you don't notice the rope stretch at all before it "pulls back."

- What is the  $k$  of a rope that stretches by 1 mm when a 100 kg weight hangs from it?
- If a boy of 50 kg hangs from the rope, how far will it stretch?
- If the boy kicks himself up a bit, and then is bouncing up and down ever so slightly, what is his frequency of oscillation? Would he notice this oscillation? If so, how? If not, why not?

3. If a 5.0 kg mass attached to a spring oscillates 4.0 times every second, what is the spring constant  $k$  of the spring?

4. A horizontal spring attached to the wall is attached to a block of wood on the other end. All this is sitting on a frictionless surface. The spring is compressed 0.3 m. Due to the compression there is 5.0 J of energy stored in the spring. The spring is then released. The block of wood experiences a maximum speed of 25m/s.

- Find the value of the spring constant.
- Find the mass of the block of wood.
- What is the equation that describes the position of the mass?
- What is the equation that describes the speed of the mass?
- Draw three complete cycles of the block's oscillatory motion on an  $x$  vs.  $t$  graph.

5. Give some everyday examples of simple harmonic motion.

6. Why doesn't the period of a pendulum depend on the mass of the pendulum weight? Shouldn't a heavier weight feel a stronger force of gravity?

7. The pitch of a Middle C note on a piano is 263 Hz. This means when you hear this note, the hairs in your ears wiggle back and forth at this frequency.

a. What is the period of oscillation for your ear hairs?

b. What is the period of oscillation of the struck wire within the piano?

8. The effective  $k$  of the diving board shown here is 800 N/m. (We say effective because it bends in the direction of motion instead of stretching like a spring, but otherwise behaves the same.) A pudgy diver is bouncing up and down at the end of the diving board, as shown. The  $y$  vs  $t$  graph is shown below.

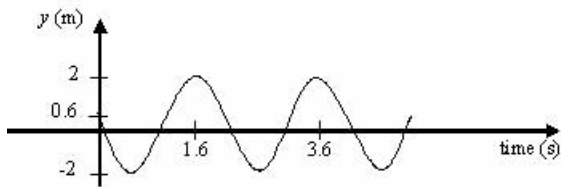
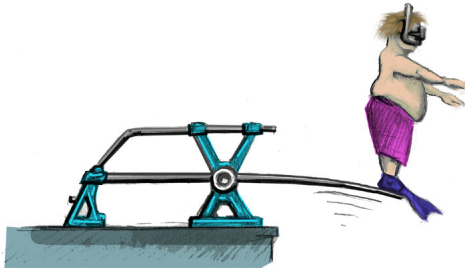

a. What is the distance between the lowest and highest points of oscillation?

b. What is the  $y$ -position of the diver at times  $t = 0$  s,  $t = 2$  s, and  $t = 4.6$  s?

c. Estimate the man's period of oscillation.

d. What is the diver's mass?

e. Write the sinusoidal equation of motion for the diver.



**Sunspot Cycles 1749 - July 2003**  
Average Monthly Count  
source: International Sunspot Count (Brussels SIDC Index)

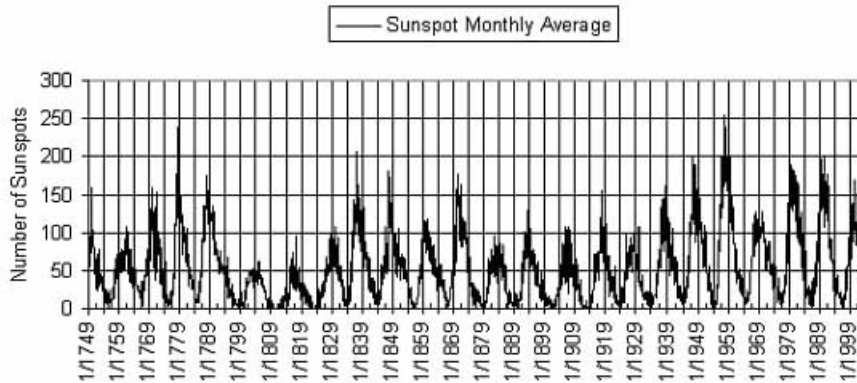

9. The Sun tends to have dark, Earth-sized spots on its surface due to kinks in its magnetic field. The number of visible spots varies over the course of years. Use the graph of the sunspot cycle above to answer the following questions. (Note that this is real data from our sun, so it doesn't look like a *perfect* sine wave. What you need to do is estimate the *best* sine wave that fits this data.)

- a. Estimate the period  $T$  in years.
- b. When do we expect the next "solar maximum?"

10. The pendulum of a small clock is 1.553 cm long. How many times does it go back and forth before the second hand goes forward one second?

11. On the moon, how long must a pendulum be if the period of one cycle is one second? The acceleration of gravity on the moon is one sixth that of Earth.

12. A spider of 0.5 g walks to the middle of her web. The web sinks by 1.0 mm due to her weight. You may assume the mass of the web is negligible.

- a. If a small burst of wind sets her in motion, with what frequency will she oscillate?
- b. How many times will she go up and down in one s? In 20 s?
- c. How long is each cycle?
- d. Draw the  $x$  vs  $t$  graph of three cycles, assuming the spider is at its highest point in the cycle at  $t=0$ s.

13. A mass on a spring on a frictionless horizontal surface undergoes SHM. The spring constant is 550N/m and the mass is 0.400 kg. The initial amplitude is 0.300 m.

- a. At the point of release find:
  - i. the potential energy
  - ii. the horizontal force on the mass
  - iii. the acceleration as it is released
- b. As the mass reaches the equilibrium point find:
  - i. the speed of the mass
  - ii. the horizontal force on the mass

iii. the acceleration of the mass

c. At a point .150 m from the equilibrium point find:

i. the potential and kinetic energy

ii. the speed of the mass

iii. the force on the mass

iv. the acceleration of the mass

d. Find the period and frequency of the harmonic motion.

14. A pendulum with a string of 0.750 m and a mass of 0.250 kg is given an initial amplitude by pulling it upward until it is at a height of 0.100 m more than when it hung vertically. This is point P. When it is allowed to swing it passes through point Q at a height of .050 m above the equilibrium position, the latter of which is called point R.

a. Draw a diagram of this pendulum motion and at points P, Q, and R draw velocity and acceleration vectors. If they are zero, state that also.

b. At point P calculate the potential energy.

c. At point R calculate the speed of the mass.

d. At point Q calculate the speed of the mass.

e. If the string were to break at points P, Q, and R draw the path the mass would take until it hits ground for each point.

f. Find the tension in the string at point P.

g. Find the tension in the string at point R.

h. Find the period of harmonic motion.

# 12. Wave Motion and Sound

AUTHOR: James H. Dann, Ph.D., James J. Dann SOURCE: The People's Physics Book LICENSE: CCSA



## The Big Idea

Objects in motion that return to the same position after a fixed period of time are said to be in *harmonic motion*. Objects in harmonic motion have the ability to transfer some of their energy over large distances. They do so by creating waves in a medium. Imagine pushing up and down on the surface of a bathtub filled with water. Water acts as the medium that carries energy from your hand to the edges of the bathtub. Waves transfer energy over a distance without direct contact of the initial source. In this sense waves are phenomena not objects.

## Key Concepts

- A *medium* is the substance through which the wave travels. For example, water acts as the medium for ocean waves, while air molecules act as the medium for sound waves.
- When a wave passes through a medium, the medium is only temporarily disturbed. When an ocean wave travels from one side of the Mediterranean Sea to the other, no actual water molecules move this great distance. Only the *disturbance* propagates (moves) through the medium.
- An object oscillating with frequency  $f$  will create waves which oscillate with the same frequency  $f$ .
- The speed  $v$  and wavelength  $\lambda$  of a wave depend on the nature of the medium through which the wave travels.
- There are two main types of waves we will consider: longitudinal waves and transverse waves.
- In longitudinal waves, the vibrations of the medium are in the *same direction* as the wave motion. A classic example is a wave traveling down a line of standing dominoes: each domino will fall in the same direction as the motion of the wave. A more physical example is a sound wave. For sound waves, high and low pressure zones move both forward and backward as the wave moves through them.
- In transverse waves, the vibrations of the medium are *perpendicular* to the direction of motion. A classic example is a wave created in a long rope: the wave travels from one end of the rope to the other, but the actual rope moves up and down, and not from left to right as the wave does.

- Water waves act as a mix of longitudinal and transverse waves. A typical water molecule pretty much moves in a circle when a wave passes through it.
- Most wave media act like a series of connected oscillators. For instance, a rope can be thought of as a large number of masses (molecules) connected by springs (intermolecular forces). The speed of a wave through connected harmonic oscillators depends on the distance between them, the spring constant, and the mass. In this way, we can model wave media using the principles of simple harmonic motion.
- The speed of a wave on a string depends on the material the string is made of, as well as the tension in the string. This fact is why tightening a string on your violin or guitar will change the sound it produces.
- The speed of a sound wave in air depends subtly on pressure, density, and temperature, but is about 343m/s at room temperature.
- Resonance is a phenomenon that occurs when something that has a natural frequency of vibration (pendulum, guitar, glass, etc.) is shaken or pushed at a frequency that is equal to its natural frequency of vibration. The most dramatic example is the collapse of the Tacoma Narrows bridge due to wind causing vibrations at the bridge's natural frequency. The result is the dramatic collapse of a very large suspension bridge.

### Key Equations

$T = 1 / f$	period and frequency are inversely related
$v = \lambda f$	wave speed equals wavelength times oscillation frequency
$f_{\text{beat}} =  f_1 - f_2 $	two interfering waves create a beat wave with frequency equal to the difference in their frequencies
$f_n = nv / 2L$	a string or pipe closed at both ends or open at both ends oscillates with this frequency; n takes all integers
$f_n = nv / 4L$	a string or pipe closed at one end oscillates with this frequency; n takes odd integers only
$f_o = f (v + v_o / v - v_s)$	Doppler shift causes a change in observed frequency, $f_o$ , if source (s) or observer (o) or both are moving closer
$f_o = f (v - v_o / v + v_s)$	Doppler shift causes an observed change in frequency if source, observer or both move apart

### Key Applications

- *Constructive interference* occurs when two waves combine to create a larger wave. This occurs when the peaks of two waves line up.
- *Destructive interference* occurs when two waves combine and cancel each other out. This occurs when a peak in one wave lines up with a trough in the other wave.
- When waves of two different frequencies interfere, a phenomenon known as *beating* occurs. The frequency of a beat is the difference of the two frequencies.
- When a wave meets a barrier, it reflects and travels back the way it came. The reflected wave may interfere with the original wave. If this occurs in precisely the right way, a *standing wave* can be created. The types of standing waves that can form depend strongly on the speed of the wave and the size of the region in which it is traveling.
- A typical standing wave is shown below. This is the motion of a simple jump-rope. *Nodes* are the places where the rope doesn't move at all; *antinodes* occur where the motion is greatest.

	<p>For this wave, the wavelength is <math>\lambda = 2L</math>. Since <math>v = \lambda f</math>, the frequency of oscillation is <math>f = v / 2L</math>.</p>
--	---

- *Higher harmonics* can also form. Note that each end, where the rope is attached, must always be a node. Below is an example of a rope in a 5<sup>th</sup> harmonic standing wave.

	<p>In general, the frequency of oscillation is <math>f = nv / 2L</math>, where <math>n</math> is the number of antinodes. The thick and dotted lines represent the wave <i>envelope</i>: these are the upper and lower limits to the motion of the string.</p>
--	--

- Importantly, each of the above standing wave examples can also apply to sound waves in a closed tube, electromagnetic waves in a wire or fiber optic cable, and so on. In other words, the standing wave examples can apply to *any* kind of wave, as long as nodes are forced at both ends by whatever is containing/reflecting the wave back on itself.
- If a node is forced at one end, but an antinode is forced at the other end, then a different spectrum of standing waves is produced. For instance, the fundamental standing sound wave produced in a tube closed at one end is shown below. In this case, the amplitude of the standing wave is referring to the magnitude of the air pressure variations.

	<p>For this standing wave, the wavelength is <math>\lambda = 4L</math>. Since <math>v = \lambda f</math>, the frequency of oscillation is <math>f = v / 4L</math>. In general, the frequency of oscillation is <math>f = nv / 4L</math>, where <math>n</math> is always odd.</p>
--	--

- When a source of a wave is moving towards you, the apparent frequency of the wave you detect is higher than that emitted. For instance, if a car approaches you while playing a note at 500 Hz, the sound you hear will be slightly higher. This familiar phenomenon is known as the *Doppler Effect*. The opposite occurs for a receding wave or if the observer moves or both move. There is a difference in the quantitative effect, depending on who is moving. (See the formulas under key equations above.) Note that these equations are for sound waves only. While the effect is similar for light and electromagnetic waves the formulas are not exactly the same as for sound.

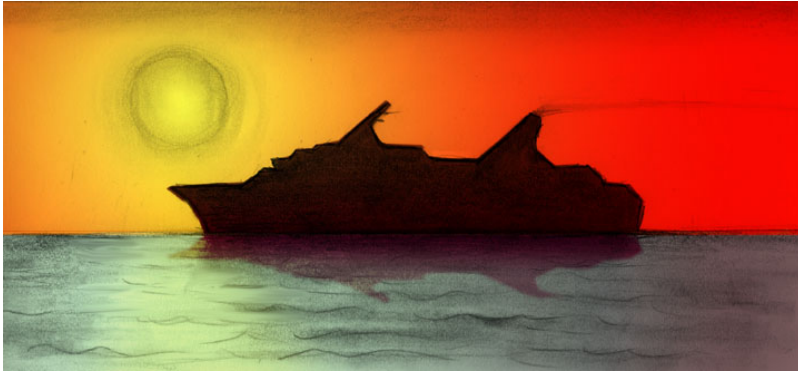

### Wave Motion and Sound Problem Set

1. A violin string vibrates, when struck, as a standing wave with a frequency of 260 Hz. When you place your finger on the same string so that its length is reduced to  $\frac{2}{3}$  of its original length, what is its new vibration frequency?

2. The simple bridge shown here oscillated up and down pretty violently four times every second as a result of an earthquake.

- What was the frequency of the shaking in Hz?
- Why was the bridge oscillating so violently?
- Calculate two other frequencies that would be considered “dangerous” for the bridge.
- What could you do to make the bridge safer?

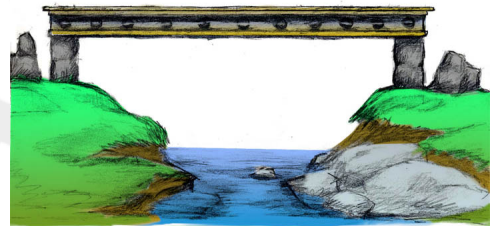

3. The speed of water waves in deep oceans is proportional to the wavelength, which is why tsunamis, with their huge wavelengths, move at incredible speeds. The speed of water waves in shallow water is proportional to depth, which is why the waves “break” at shore. Draw a sketch which accurately portrays these concepts.

4. Below you will find actual measurements of acceleration as observed by a seismometer during a relatively small earthquake.

$a$  ( $\text{m/s}^2$ )

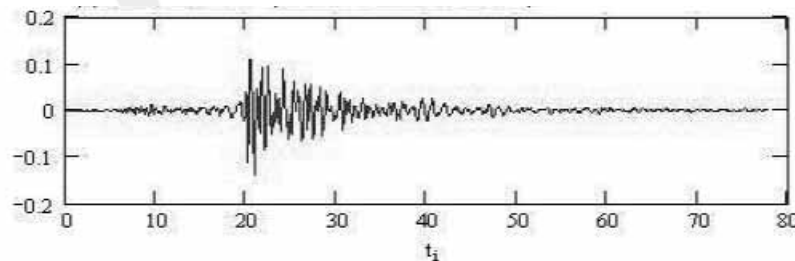

Time  $t$  (sec)

An earthquake can be thought of as a whole bunch of different waves all piled up on top of each other.

- Estimate (using a ruler) the approximate period of oscillation  $T$  of the minor aftershock which occurs around  $t = 40$  sec.
- Convert your estimated period from part (a) into a frequency  $f$  in Hz.

c. Suppose a wave with frequency  $f$  from part (b) is traveling through concrete as a result of the earthquake. What is the wavelength  $\lambda$  of that wave in meters? (The speed of sound in concrete is approximately  $v = 3200$  m/s.)

5. The length of the western section of the Bay Bridge is 2.7 km.



a. Draw a side-view of the western section of the Bay Bridge and identify all the 'nodes' in the bridge.

b. Assume that the bridge is concrete (the speed of sound in concrete is 3200 m/s). What is the lowest frequency of vibration for the bridge? (You can assume that the towers are equally spaced, and that the central support is equidistant from both middle towers. The best way to approach this problem is by drawing in a wave that "works.")

c. What might happen if an earthquake occurs that shakes the bridge at precisely this frequency?

6. The speed of sound  $v$  in air is approximately  $331.4 \text{ m/s} + 0.6T$ , where  $T$  is the temperature of the air in Celsius. The speed of light  $c$  is 300,000 km/sec, which means it travels from one place to another on Earth more or less instantaneously. Let's say on a cool night (air temperature  $10^\circ$  Celsius) you see lightning flash and then hear the thunder rumble five seconds later. How far away (in km) did the lightning strike?

7. Human beings can hear sound waves in the frequency range 20 Hz – 20 kHz. Assuming a speed of sound of 343 m/s, answer the following questions.

a. What is the shortest wavelength the human ear can hear?

b. What is the longest wavelength the human ear can hear?

8. The speed of light  $c$  is 300,000 km/sec.

a. What is the frequency in Hz of a wave of red light ( $\lambda = 0.7 \times 10^{-6}$  m)?

b. What is the period  $T$  of oscillation (in seconds) of an electron that is bouncing up and down in response to the passage of a packet of red light? Is the electron moving rapidly or slowly?

9. Radio signals are carried by electromagnetic waves (i.e. light waves). The radio waves from San Francisco radio station KMEL (106.1 FM) have a frequency of 106.1 MHz. When these waves reach your antenna, your radio converts the motions of the electrons in the antenna back into sound.

a. What is the wavelength of the signal from KMEL?

b. What is the wavelength of a signal from KPOO (89.5 FM)?

c. If your antenna were broken off so that it was only 2 cm long, how would this affect your reception?

10. Add together the two sound waves shown below and sketch the resultant wave. Be as exact as possible – using a ruler to line up the waves will help. The two waves have different frequencies, but the same amplitude. What is the frequency of the resultant wave? How will the resultant wave sound different?

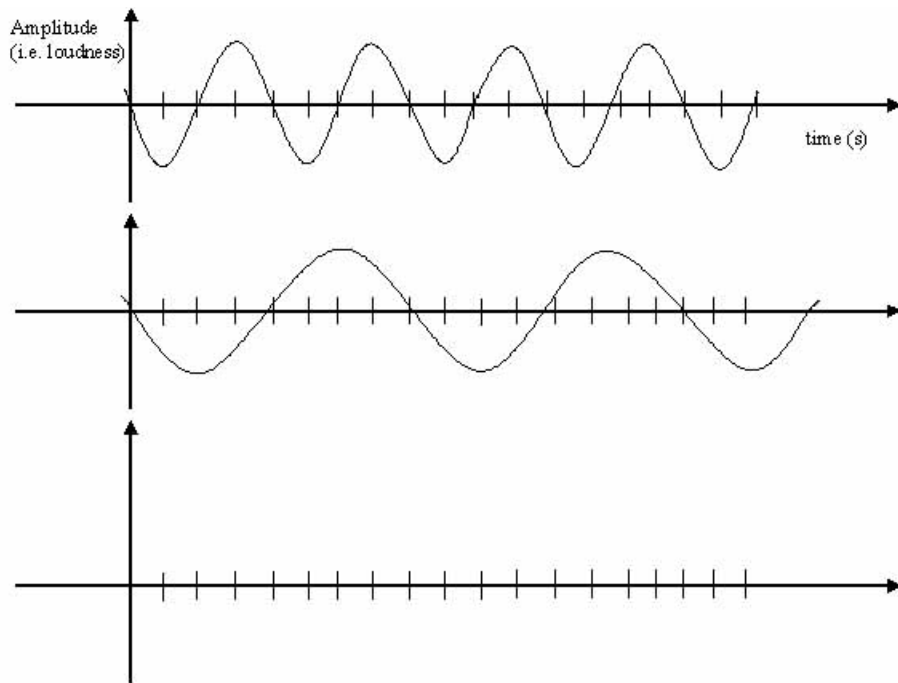

11. Aborigines, the native people of Australia, play an instrument called the didgeridoo like the one shown above. The didgeridoo produces a low pitch sound and is possibly the world's oldest instrument. The one shown above is about 1.3 m long and open at both ends.

a. Knowing that when a tube is open at both ends there must be an antinode at both ends, draw the first 3 harmonics for this instrument.

b. Derive a generic formula for the frequency of the  $n$ th standing wave mode for the didgeridoo, as was done for the string tied at both ends and for the tube open at one end.

12. Reread the difference between *transverse* and *longitudinal* waves. For each of the following types of waves, tell what type it is and why. (Include a sketch for each.)

- sound waves
- water waves in the wake of a boat
- a vibrating string on a guitar
- a swinging jump rope
- the vibrating surface of a drum
- the “wave” done by spectators at a sports event
- slowly moving traffic jams



13. At the Sunday drum circle in Golden Gate Park, an Indian princess is striking her drum at a frequency of 2 Hz. You would like to hit your drum at another frequency, so that the sound of your drum and the sound of her drum “beat” together at a frequency of 0.1 Hz. What frequencies could you choose?



14. A guitar string is 0.70 m long and is tuned to play an E note ( $f = 330$  Hz). How far from the end of this string must your finger be placed to play an A note ( $f = 440$  Hz)?
15. Piano strings are struck by a hammer and vibrate at frequencies that depend on the length of the string. A certain piano string is 1.10 m long and has a wave speed of 80 m/s. Draw sketches of each of the four lowest frequency nodes. Then, calculate their wavelengths and frequencies of vibration.
16. Suppose you are blowing into a soda bottle that is 20 cm in length and closed at one end.
- Draw the wave pattern in the tube for the lowest four notes you can produce.
  - What are the frequencies of these notes?
17. You are inspecting two long metal pipes. Each is the same length; however, the first pipe is open at one end, while the other pipe is closed at both ends.
- Compare the wavelengths and frequencies for the fundamental tones of the standing sound waves in each of the two pipes.
  - The temperature in the room rises. What happens to the frequency and wavelength for the open-on-one-end pipe?
18. A train, moving at some speed lower than the speed of sound, is equipped with a gun. The gun shoots a bullet forward at precisely the speed of sound, relative to the train. An observer watches some distance down the tracks, with the bullet headed towards him. Will the observer hear the sound of the bullet being fired before being struck by the bullet? Explain.
19. A 120 cm long string vibrates as a standing wave with four antinodes. The wave speed on the string is 48 m/s. Find the wavelength and frequency of the standing wave.
20. A tuning fork that produces a frequency of 375 Hz is held over pipe open on both ends. The bottom end of the pipe is adjustable so that the length of the tube can be set to whatever you please.
- What is the shortest length the tube can be and still produce a standing wave at that frequency?
  - The second shortest length?
  - The one after that?
21. The speed of sound in hydrogen gas at room temperature is 1270 m/s. Your flute plays notes of 600, 750, and 800 Hz when played in a room filled with normal air. What notes would the flute play in a room filled with hydrogen gas?
22. A friend plays an A note (440 Hz) on her flute while hurtling toward you in her imaginary space craft at a speed of 40 m/s. What frequency do you hear just before she rams into you?
23. How fast would a student playing an A note (440 Hz) have to move towards you in order for you to hear a G note (784 Hz)?
24. Students are doing an experiment to determine the speed of sound in air. They hold a tuning fork above a large empty graduated cylinder and try to create resonance. The air column in the graduated cylinder can be adjusted by putting water in it. At a certain point for each tuning fork a clear resonance point is heard. The students adjust the water finely to get the peak resonance then carefully measure the air column from water to top of air column. (The assumption is that the tuning fork itself creates an anti-node and the water creates a node.) The following data table was developed:

Frequency OF tuning fork (Hz)	Length of air column (cm)	Wavelength (m)	Speed of sound (m/s)
-------------------------------	---------------------------	----------------	----------------------

184	46		
328	26		
384	22		
512	16		
1024	24		

- Fill out the last two columns in the data table.
- Explain major inconsistencies in the data or results.
- The graduated cylinder is 50 cm high. Were there other resonance points that could have been heard? If so what would be the length of the wavelength?
- What are the inherent errors in this experiment?

DRAFT

# 13. Electricity

AUTHOR: James H. Dann, Ph.D., James J. Dann SOURCE: The People's Physics Book LICENSE: CCSA



## The Big Idea

*Conservation of charge* is the fourth of the five conservation laws in physics. There are two charges, + and -, and the symmetry of the electric charge indicates that the total charge in the universe remains the same. In any closed system charge can be transferred from one body to another or can move within the system but the total electric charge remains constant.

*Electromagnetism* is associated with charge and is a fundamental force of nature, like gravity. If charges are static, the only manifestation of electromagnetism is the *Coulomb electric force*. In the same way that the gravitational force depends on mass, the Coulomb electric force depends on the property known as electric *charge*. Like gravity, the Coulomb electric Force decreases with the square of the distance. The Coulomb electric force is responsible for many of the forces we discussed previously: the normal force, contact forces, friction, and so on - *all* of these forces arise in the mutual attraction and repulsion of charged particles.

The law determining the magnitude of the Coulomb electric force has the same form as the law of gravity. However the electric constant is 20 orders of magnitude greater than the gravitational constant. That is why electricity normally dominates gravity at the atomic and molecular level. Since there is only one type of mass but two types of charge, gravity will dominate in large bodies *unless there is a separation of charge*.

## Key Equations

$q = Ne$	the total charge of an object is always some integer $N$ multiplied by the fundamental charge $e = 1.6 \times 10^{-19} \text{ C}$ .
$F = kq_1q_2/r^2$	the force exerted by two charges on one another depends on the magnitude of the charges, the distance between them, and a fundamental constant $k = 9 \times 10^9 \text{ Nm}^2/\text{C}^2$ .
$F = qE$	a charged object in an electric field feels a force.
$E = kq/r^2$	the electric field produced by a charged object depends on the charge of the object and the distance to the object.
$\Delta U_E = q\Delta V$	a charged object gains electric potential energy by moving through a changing electric potential.

$E = -\Delta V/\Delta x$	the electric field depends on how quickly the electric potential varies over space; alternatively $\Delta V = -E \cdot \Delta x$ . Fields point “downhill” in potential.
$V = kq/r$	the electric potential produced by a charged object depends on the charge of the object and the distance to the object.

### Key Concepts

- Electrons have negative charge and protons have positive charge. The magnitude of the charge is the same for both:  $e$ .
- In any process, electric charge is conserved. The total electric charge of the universe does not change. Therefore, electric charge can only be transferred – not lost – from one body to another.
- Normally, electric charge is transferred when electrons leave the outer orbits of the atoms of one body (leaving it positively charged) and move to the surface of another body (causing the new surface to gain a negative net charge). In a plasma all electrons are stripped from the atoms, leaving positively charged ions and free electrons.
- Similarly-charged objects have a repulsive force between them. Oppositely charged objects have an attractive force between them.
- The value of the electric field tells you the force that a charged object would feel *if* it entered this field. Electric field lines tell you the direction a positive charge would go if it were placed in the field.
- Electric potential is measured in units of Volts (V) – thus electric potential is often referred to as “voltage.” Electric potential is the source of the electric potential energy.
- Positive charges move towards lower electric potential; negative charges move toward higher electric potential

### Key Applications

- In problems that ask for excess negative or positive charge, remember that each electron has one unit of the fundamental charge  $e$ .
- To find the speed of a particle after it traverses a voltage difference, use the equation for the conservation of energy:  $q\Delta V = \frac{1}{2}mv^2$
- Force and electric field are vectors. Use your vector math skills (i.e. keep the  $x$  and  $y$  directions separate) when solving two-dimensional problems.

### Electricity Problem Set

1. After sliding your feet across the rug, you touch the sink faucet and get shocked. Explain what is happening.
2. What is the net charge of the universe? Of your toaster?
3. As you slide your feet along the carpet, you pick up a net charge of  $+4 \text{ mC}$ . Which of the following is true?
  - a. You have an excess of  $2.5 \times 10^{16}$  electrons
  - b. You have an excess of  $2.5 \times 10^{19}$  electrons
  - c. You have an excess of  $2.5 \times 10^{16}$  protons
  - d. You have an excess of  $2.5 \times 10^{19}$  protons

4. You rub a glass rod with a piece of fur. If the rod now has a charge of  $-0.6 \mu\text{C}$ , how many electrons have been added to the rod?

- a.  $3.75 \times 10^{18}$
- b.  $3.75 \times 10^{12}$
- c. 6000
- d.  $6.00 \times 10^{12}$
- e. Not enough information

5. What is the direction of the electric field if an electron initially at rest begins to move in the North direction as a result of the field?

- a. North
- b. East
- c. West
- d. South
- e. Not enough information

6. Two metal plates have gained excess electrons in differing amounts through the application of rabbit fur. The arrows indicate the direction of the electric field which has resulted. Three electric potential lines, labeled A, B, and C are shown. Order them from the greatest electric potential to the least.

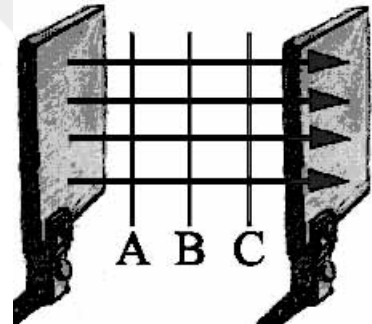

- a. A, B, C
- b. C, B, A
- c. B, A, C
- d. B, C, A
- e.  $A = B = C$  ... they're all at the same potential

7. The diagram to the right shows a negatively charged electron. Order the electric potential lines from greatest to least.

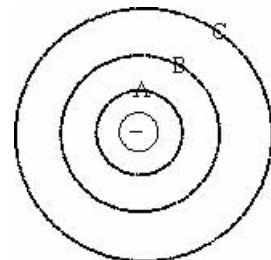

- a. A, B, C
- b. C, B, A
- c. B, A, C
- d. B, C, A
- e.  $A = B = C$  ... they're all at the same electric potential

8. The three arrows shown here represent the magnitudes of the electric field and the directions at the tail end of each arrow. Consider the distribution of charges which would lead to this arrangement of electric

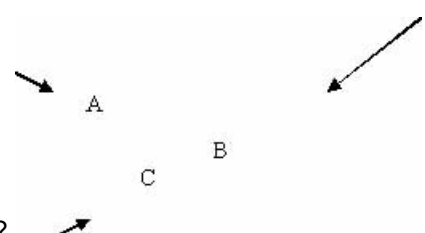

fields. Which of the following is most likely to be the case here?

- a. A positive charge is located at point A
- b. A negative charge is located at point B
- c. A positive charge is located at point B and a negative charge is located at point C
- d. A positive charge is located at point A and a negative charge is located at point C
- e. Both answers a) and b) are possible

9. Particles *A* and *B* are both positively charged. The arrows shown indicate the direction of the *forces* acting on them due to an applied electric field (not shown in the picture). For each, draw in the electric field lines that would best match the observed force.

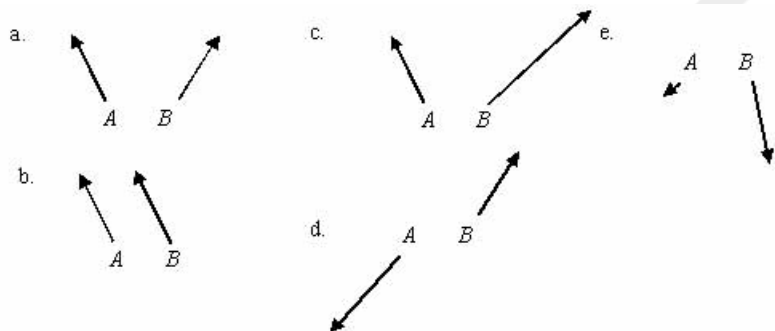

10. To the right are the electric potential lines for a certain arrangement of charges. Draw the direction of the electric field for all the black dots.

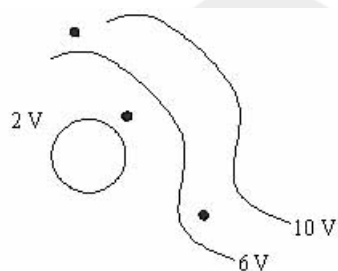

11. A suspended pith ball possessing  $+10 \mu\text{C}$  of charge is placed  $0.02 \text{ m}$  away from a metal plate possessing  $-6 \mu\text{C}$  of charge.

- a. Are these objects attracted or repulsed?
- b. What is the force on the negatively charged object?
- c. What is the force on the positively charged object?

12. Calculate the electric field a distance of  $4.0 \text{ mm}$  away from a  $-2.0 \mu\text{C}$  charge. Then, calculate the force on a  $-8.0 \mu\text{C}$  charge placed at this point.

13. Consider the hydrogen atom. Does the electron orbit the proton due to the force of gravity or the electric force? Calculate both forces and compare them. (You may need to look up the properties of the hydrogen atom to complete this problem.)

14. As a great magic trick, you will float your little sister in the air using the force of opposing electric charges. If your sister has 40 kg of mass and you wish to float her 0.5 m in the air, how much charge do you need to deposit both on her and on a metal plate directly below her? Assume an equal amount of charge on both the plate and your sister.

15. Copy the arrangement of charges below. Draw the electric field from the  $-2\text{ C}$  charge in one color and the electric field from the  $+2\text{ C}$  charge in a different color. Be sure to indicate the directions with arrows. Now take the individual electric field vectors, add them together, and draw the resultant vector. This is the electric field created by the two charges together.

  $-2\text{ C}$

  $+2\text{ C}$

16. A proton traveling to the right moves in between the two large plates. A vertical electric field, pointing downwards with magnitude  $3.0\text{ N/C}$ , is produced by the plates.

a. What is the direction of the force on the proton?

b. Draw the electric field lines on the diagram.

c. If the electric field is  $3.0\text{ N/C}$ , what is the acceleration of the proton in the region of the plates?

d. Pretend the force of gravity doesn't exist; then sketch the path of the proton.

e. We take this whole setup to another planet. If the proton travels straight through the apparatus without deflecting, what is the acceleration of gravity on this planet?

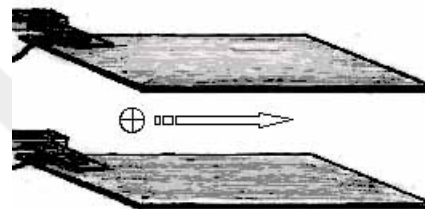

17. A molecule shown by the square object shown below contains an excess of 100 electrons.

a. What is the direction of the electric field at point A,  $2.0 \times 10^{-9}\text{ m}$  away?



A

b. What is the value of the electric field at point A?

c. A molecule of charge  $8.0\text{ }\mu\text{C}$  is placed at point A. What are the magnitude and direction of the force acting on this molecule?

18. Two negatively charged spheres (one with  $-12\text{ }\mu\text{C}$ ; the other with  $-3\text{ }\mu\text{C}$ ) are 3 m apart. Where could you place an electron so that it will be suspended in space between them with zero net force?

*For problems 19, 20, and 21 assume 3-significant digit accuracy in all numbers and coordinates. All charges are positive.*

19. Find the direction and magnitude of the force on the charge at the origin (see picture). The object at the origin has a charge of  $8\text{ }\mu\text{C}$ , the object at coordinates  $(-2\text{ m}, 0)$  has a charge of  $12\text{ }\mu\text{C}$ , and the object at coordinates  $(0, -4\text{ m})$  has a charge of  $44\text{ }\mu\text{C}$ . All distance units are in meters.

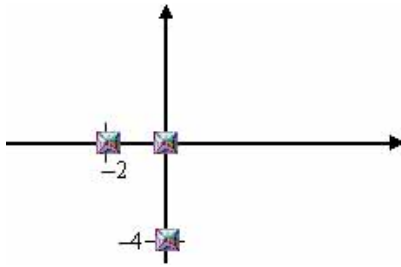

20. A 2 C charge is located at the origin and a 7 C charge is located at (0, 6 m). Find the electric field at the coordinate (10 m, 0). It may help to draw a sketch.

21. A metal sphere with a net charge of  $+5 \mu\text{C}$  and a mass of 400 g is placed at the origin and held fixed there.

a. Find the electric potential at the coordinate (6 m, 0).

b. If another metal sphere of  $-3 \mu\text{C}$  charge and mass of 20 g is placed at the coordinate (6 m, 0) and left free to move, what will its speed be just before it collides with the metal sphere at the origin?

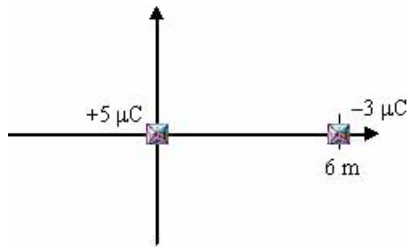

22. Collisions of electrons with the surface of your television set give rise to the images you see. How are the electrons accelerated to high speed? Consider the following: two metal plates (The right hand one has small holes allow electrons to pass through to the surface of the screen.), separated by 30 cm, have a uniform electric field between them of 400 N/C.

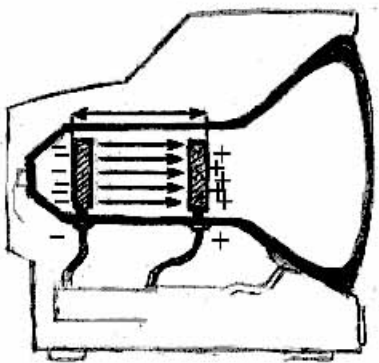

a. Find the force on an electron located at a point midway between the plates

b. Find the voltage difference between the two plates

c. Find the change in electric potential energy of the electron when it travels from the back plate to the front plate

d. Find the speed of the electron just before striking the front plate (the screen of your TV)



23. Two pith balls of equal and like charges are repulsed from each other as shown in the figure below. They both have a mass of 2 g and are separated by  $30^\circ$ . One is hanging freely from a 0.5 m string, while the other, also hanging from a 0.5 m string, is stuck like putty to the wall.

- Draw the free body diagram for the hanging pith ball
- Find the distance between the leftmost pith ball and the wall (this will involve working a geometry problem)
- Find the tension in the string (Hint: use y-direction force balance)
- Find the amount of charge on the pith balls (Hint: use x-direction force balance)

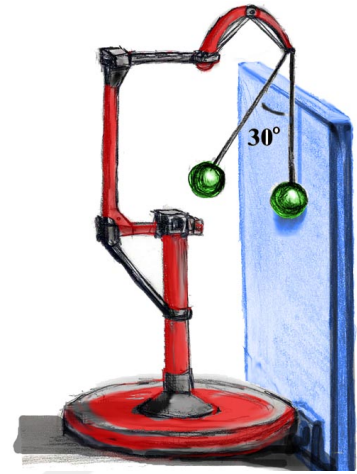

DRAFT

# 14. Electric Circuits: Batteries and Resistors

AUTHOR: James H. Dann, Ph.D., James J. Dann SOURCE: The People's Physics Book LICENSE: CCSA

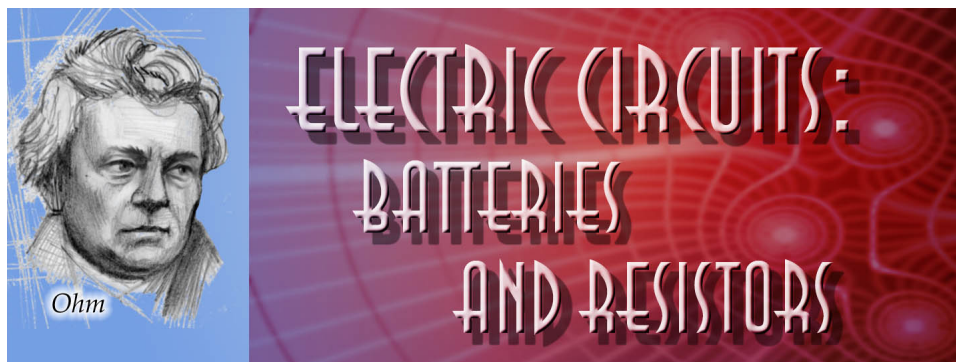

## The Big Ideas

The name *electric current* is given to the phenomenon that occurs when an electric field moves down a wire at close to the speed of light. *Voltage* is the electrical energy density (energy divided by charge) and differences in this density (voltage) cause electric current. *Resistance* is the amount a device in the wire resists the flow of current by converting electrical energy into other forms of energy. A device, the resistor, could be a light bulb, transferring electrical energy into heat and light or an electric motor that converts electric energy into mechanical energy. The difference in energy density across a resistor or other electrical device is called *voltage drop*.

In electric *circuits* (closed loops of wire with resistors and constant voltage sources) energy must be conserved. It follows that changes in energy density, the algebraic sum of voltage drops and voltage sources, around any closed loop will equal zero.

In an electric *junction* there is more than one possible path for current to flow. For charge to be conserved at a junction the current into the junction must equal the current out of the junction.

## Key Concepts:

- **Ohm's Law**  $V=IR$  (Voltage drop equals current times resistance.)



This is the main equation for electric circuits but it is often misused. In order to calculate the voltage drop across a light bulb use the formula:  $V_{lightbulb} = I_{lightbulb}R_{lightbulb}$ . For the *total* current flowing out of the power source, you need the *total* resistance of the circuit and the *total*

$$\text{current: } V_{total} = I_{total}R_{total}$$

- **Power** is the rate that energy is released. The units for power are Watts (W), which equal Joules per second  $[W] = [J]/[s]$ . Therefore, a 60 W light bulb releases 60 Joules of energy every second.

The equations used to calculate the **power** dissipated in a circuit is  $P=IV$ . As with Ohm's Law, one must be careful not to mix apples with oranges. If you want the power of the entire circuit, then you multiply the *total* voltage of the power source by the *total* current coming out of the power source. If you want the power dissipated (i.e. released) by a light bulb, then you multiply the *voltage drop* across the light bulb by the *current*

going through that light bulb.

Name	Symbol	Electrical Symbol	Units	Analogy	Everyday device
Voltage	<b>V</b>		Volts (V)	A water dam with pipes coming out at different heights. The lower the pipe along the dam wall, the larger the water pressure, thus the higher the voltage.	Battery, the plugs in your house, etc.
Current	<b>I</b>		Amps (A) A = C/s	A river of water. Objects connected in series are all on the same river, thus receive the same current. Objects connected in parallel make the main river branch into smaller rivers. These guys all have different currents.	Whatever you plug into your wall sockets draws current
Resistance	<b>R</b>		Ohm (Ω)	If current is analogous to a river, then resistance is the amount of rocks in the river. The bigger the resistance the less current that flows	Light bulb, Toaster, etc.

- **Resistors in Series:** All resistors are connected end to end. There is only one river, so they all receive the same current. But since there is a voltage drop across each resistor, they may all have different voltages across them. The more resistors in series the more rocks in the river, so the less current that flows.

$$R_{total} = R_1 + R_2 + R_3 + \dots$$

- **Resistors in Parallel:** All resistors are connected together at both ends. There are many rivers (i.e. The main river branches off into many other rivers), so all resistors receive different amounts of current. But since they are all connected to the same point at both ends they all receive the same voltage.

$$\frac{1}{R_{total}} = \frac{1}{R_1} + \frac{1}{R_2} + \frac{1}{R_3} + \dots$$

- **DC Power:** Voltage and current flow in one direction. Examples are batteries and the power supplies we use in class. **AC Power:** Voltage and current flow in alternate directions. In the US they reverse direction 60 times a second. (This is a more efficient way to transport electricity and electrical devices do not care which way it flows as long as current is flowing. Note: your TV and computer screen are actually flickering 60 times a second due to the alternating current that comes out of household plugs. Our eyesight does not work this fast, so we never notice it. However, if you film a TV or computer screen the effect is observable due to the mismatched frame rates of the camera and TV screen.) Electrical current coming out of your plug is an example.

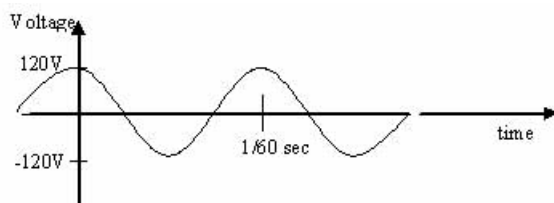

- **Ammeter:** A device that measures electric current. You must break the circuit to measure the current. Ammeters have very low resistance; therefore you must wire them in series.
- **Voltmeter:** A device that measures voltage. In order to measure a voltage difference between two points, place the probes down on the wires for the two points. Do not break the circuit. Volt meters have very high resistance; therefore you must wire them in parallel.
- **Voltage source:** A power source that produces fixed voltage regardless of what is hooked up to it. A battery is a real-life voltage source. A battery can be thought of as a perfect voltage source with a small resistor (called internal resistance) in series. The electric energy density produced by the chemistry of the battery is called **emf**, but the amount of voltage available from the battery is called **terminal voltage**. The terminal voltage equals the emf minus the voltage drop across the internal resistance (current of the external circuit times the internal resistance.)

### Key Equations:

$I = \Delta q / \Delta t$	current is the rate at which charge passes by; the units of current are Amperes ( $1 \text{ A} = 1 \text{ C/s}$ ).
$\Delta V = I R$	the current flow through a resistor depends on the applied electric potential difference across it; the units of resistance are Ohms ( $1 \Omega = 1 \text{ V/A}$ ).
$P = I \cdot \Delta V$	the power dissipated by a resistor is the product of the current through the resistor and the applied electric potential difference across it; the units of power are Watts ( $1 \text{ W} = 1 \text{ J/s}$ ).

### Electric Circuits Problem Set

- The current in a wire is 4.5 A.
  - How many coulombs per second are going through the wire?
  - How many electrons per second are going through the wire?
- A light bulb with resistance of  $80 \Omega$  is connected to a 9 V battery.
  - What is the electric current going through it?
  - What is the power (i.e. wattage) dissipated in this light bulb with the 9 V battery?
  - How many electrons leave the battery every hour?
  - How many Joules of energy leave the battery every hour?
- A 120 V, 75 W light bulb is shining in your room and you ask yourself...
  - What is the resistance of the light bulb?
  - How bright would it shine with a 9 V battery (i.e. what is its power output)?
- A bird is standing on an electric transmission line carrying 3000A of current. A wire like this has about  $3.0 \times 10^{-5} \Omega$  of resistance per meter. The bird's feet are 6 cm apart. The bird, itself, has a resistance of about  $4 \times 10^5 \Omega$ .
  - What voltage does the bird feel?
  - What current goes through the bird?

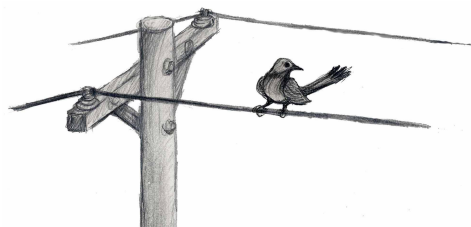

c. What is the power dissipated by the bird?

d. By how many Joules of energy does the bird heat up every hour?

5. Which light bulb will shine brighter? Which light bulb will shine for a longer amount of time? Draw the schematic diagram for both situations. Note that the objects on the right are batteries, not resistors.

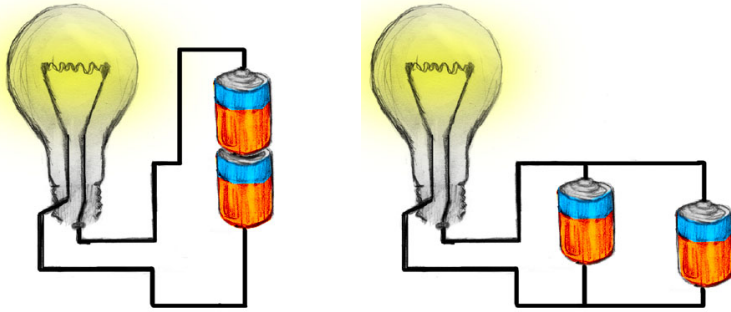

6. Regarding the circuit to the right.

a. If the ammeter reads 2 A, what is the voltage?

b. How many watts is the power supply supplying?

c. How many watts are dissipated in each resistor?

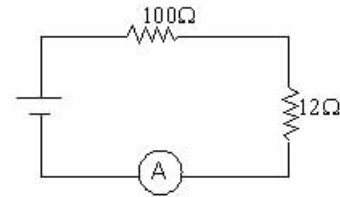

7. Three  $82 \Omega$  resistors and one  $12 \Omega$  resistor are wired in parallel with a 9 V battery.

a. Draw the schematic diagram.

b. What is the total resistance of the circuit?

8. What will the ammeter read for the circuit shown to the right?

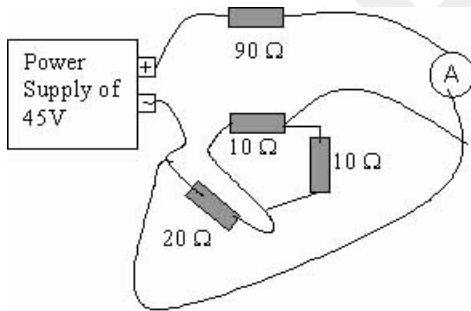

9. Draw the schematic of the following circuit.

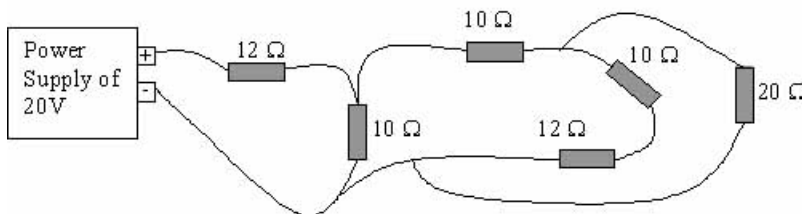

10. What does the ammeter read and which resistor is dissipating the most power?

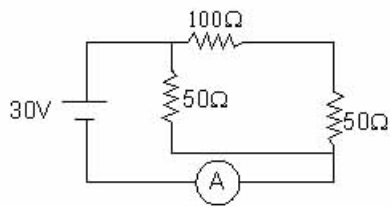

11. Analyze the circuit below.

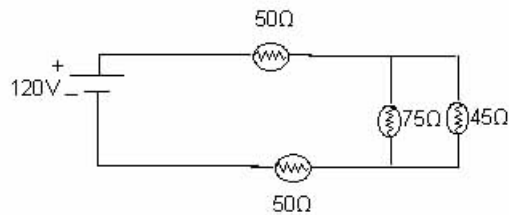

- Find the current going out of the power supply
- How many Joules per second of energy is the power supply giving out?
- Find the current going through the 75 Ω light bulb.
- Find the current going through the 50 Ω light bulbs (hint: it's the same, why?).
- Order the light bulbs in terms of brightness
- If they were all wired in parallel, order them in terms of brightness.

12. Find the total current output by the power supply and the power dissipated by the 20Ω resistor.

13. You have a 600 V power source, two 10Ω toasters that both run on 100 V and a 25 Ω resistor.

- Show me how you would wire them up so the toasters run properly.
- What is the power dissipated by the toasters?
- Where would you put the fuses to make sure the toasters don't draw more than 15 Amps?
- Where would you put a 25 Amp fuse to prevent a fire (if too much current flows through the wires they will heat up and possibly cause a fire)?

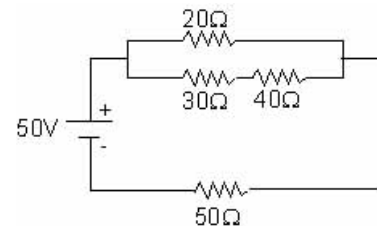

14. Look at the following scheme of four identical light bulbs connected as shown. Answer the questions below giving a justification for your answer:

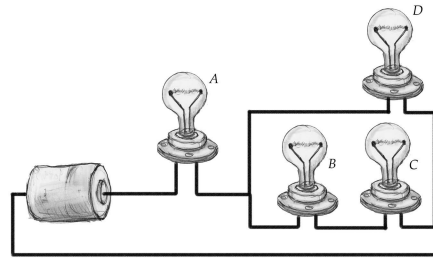

- Which of the four light bulbs is the brightest?
- Which light bulbs are the dimmest?
- Tell in the following cases which other light bulbs go out if:
  - bulb A goes out
  - bulb B goes out
  - bulb D goes out
- Tell in the following cases which other light bulbs get dimmer, and which get brighter if:
  - bulb B goes out
  - bulb D goes out

15. Refer to the circuit diagram below and answer the following questions.

- What is the resistance between A and B?
- What is the resistance between C and B?
- What is the resistance between D and E?
- What is the the total equivalent resistance of the circuit?
- What is the current leaving the battery?
- What is the voltage drop across the  $12\ \Omega$  resistor?
- What is the voltage drop between D and E?
- What is the voltage drop between A and B?
- What is the current through the  $25\ \Omega$  resistor?
- What is the total energy dissipated in the  $25\ \Omega$  if it is in use for 11 hours?

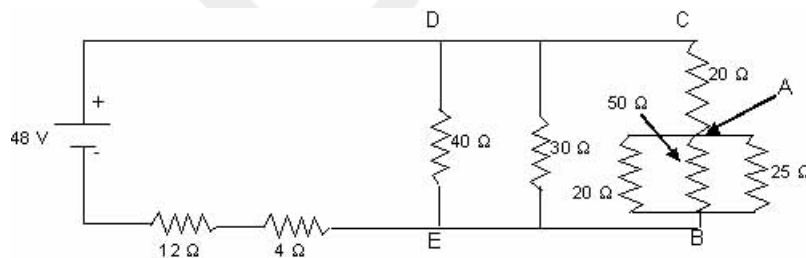

16. In the circuit shown here, the battery produces an *emf* of  $1.5\ \text{V}$  and has an internal resistance of  $0.5\ \Omega$ .

- Find the total resistance of the external circuit.
- Find the current drawn from the battery.
- Determine the terminal voltage of the battery

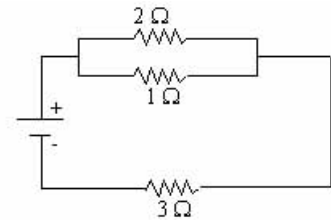

d. Show the proper connection of an ammeter and a voltmeter that could measure voltage across and current through the  $2\ \Omega$  resistor. What measurements would these instruments read?

17. Students measuring an unknown resistor take the following measurements:

Voltage (v)	Current (a)
15	.11
12	.08
10	.068
8	.052
6	.04
4	.025
2	.01

- Show a circuit diagram with the connections to the power supply, ammeter and voltmeter.
- Graph voltage vs. current; find the best-fit straight line.
- Use this line to determine the resistance.
- How confident can you be of the results?
- Use the graph to determine the current if the voltage were 13 V.

18. Students are now measuring the terminal voltage of a battery hooked up to an external circuit. They change the external circuit four times and develop the following table of data:

Terminal Voltage (v)	Current (a)
14.63	.15
14.13	.35
13.62	.55
12.88	.85

- Graph this data, with the voltage on the vertical axis.
- Use the graph to determine the emf of the battery.
- Use the graph to determine the internal resistance of the battery.
- What voltage would the battery read if it were not hooked up to an external circuit?

19. Students are using a variable power supply to quickly increase the voltage across a resistor. They measure the current and the time the power supply is on. The following table of data is developed:

Time (sec)	Voltage (v)	Current (a)
0	0	0



2	10	1.0
4	20	2.0
6	30	3.0
8	40	3.6
10	50	3.8
12	60	3.5
14	70	3.1
16	80	2.7
18	90	2.0

- a. Graph voltage vs. current
- b. Explain the probable cause of the anomalous data after 8 seconds
- c. Determine the likely value of the resistor and explain how you used the data to support this determination.
- d. Graph power vs. time
- e. Determine the total energy dissipation during the 18 seconds.

20. You are given the following three devices and a power supply of exactly 120v.

\* Device X is rated at 60 V and 0.5 A \* Device Y is rated at 15 w and 0.5 A \* Device Z is rated at 120 V and 1800 w

Design a circuit that obeys the following rules: you may only use the power supply given, one sample of each device, and an extra, single resistor of any value (you choose). Also, each device must be run at their rated values.

21. Given three resistors, 200  $\Omega$ , 300  $\Omega$  and 600  $\Omega$  and a 120 V power source connect them in a way to heat a container of water as rapidly as possible.

- a. Show the circuit diagram
- b. How many joules of heat are developed after 5 minutes?

22. Construct a circuit using the following devices: a 120 V power source. Two 9  $\Omega$  resistors, device A rated at 1 A, 6 V; device B rated at 2 A, 60 V; device C rated at 225 w, 3 A; device D rated at 15w, 15 V.

23. You have a battery with an emf of 12 V and an internal resistance of 1.00  $\Omega$ . Some 2.00 A are drawn from the external circuit.

- a. What is the terminal voltage
- b. The external circuit consists of device X, 0.5 A and 6 V; device Y, 0.5 A and 10 V, and two resistors. Show how this circuit is connected.
- c. Determine the value of the two resistors.

24. Students use a variable power supply an ammeter and three voltmeters to measure the voltage drops across three unknown resistors. The power supply is slowly cranked up and the following table of data is developed:

Current (ma)	Voltage $R_1$ (v)	Voltage $R_2$ (v)	Voltage $R_3$ (v)
100	2.1	3.6	5.1

150	3.0	5.0	7.7
200	3.9	7.1	10.0
250	5.0	8.9	12.7
300	6.2	10.8	15.0
350	7.1	12.7	18.0
400	7.9	14.3	20.0
450	9.0	16.0	22.0
500	10.2	18.0	25.0
600	12.5	21.0	31.0
700	14.0	25.0	36.0

- Draw a circuit diagram, showing the ammeter and voltmeter connections.
- Graph the above data with voltage on the vertical axis.
- Use the slope of the best-fit straight line to determine the values of the three resistors.
- Quantitatively discuss the confidence you have in the results
- What experimental errors are most likely might have contributed to any inaccuracies.

# 15. Magnetism

AUTHOR: James H. Dann, Ph.D., James J. Dann SOURCE: The People's Physics Book LICENSE: CCSA



## The Big Idea

For static electric charges, the electromagnetic force is manifested by the Coulomb electric force alone. If charges are moving, however, there is created an additional force, called magnetism. Our realization in the 19<sup>th</sup> century that electricity and magnetism are aspects of the same force completely changed the world we live in. Moving charges – electric current – create magnetic fields. Varying magnetic fields create electric fields. Thus a loop of wire in a changing magnetic field will have current induced in it. This is called *electromagnetic induction*.

## Key Concepts

- Magnetic fields are generated by charged particles in motion.
- Magnetic fields exert magnetic forces on charged particles in motion.
- Permanent magnets (like refrigerator magnets) consist of atoms, such as iron, for which the magnetic moments (roughly electron spin) of the electrons are “lined up” all across the atom. This means that their magnetic fields add up, rather than canceling each other out. The net effect is noticeable because so many atoms have lined up.
- Changing magnetic fields passing through a loop of wire generate currents in that wire; this is how electric power generators work. Likewise, the changing amounts of current in a wire create a changing magnetic field; this is how speakers and electric motors work.
- Magnetic fields have a “3-D” property, obliging you to use special vector rules (called right hand rules) to figure out the directions of forces, fields, and currents.

o **Right Hand Rule #1**

A wire with electric current going through it produces a magnetic field going in circles around it. To find the direction of the magnetic field, point your thumb in the direction of the current. Then, curl your fingers around the wire. The direction your fingers curl tells you the direction that the magnetic field is pointing. Be sure to use your right hand!

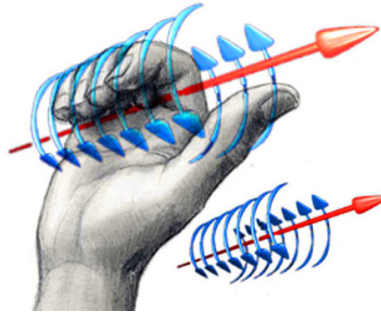

o **Right Hand Rule #2**

Point your index finger along the direction of the particle's velocity or the direction of the current. Your middle finger goes in the direction of the magnetic field and your thumb tells you the direction of the force. NOTE: For negative charge reverse the direction of the force (or use your left hand)

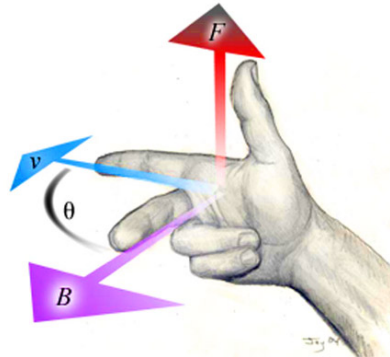

**Key Equations and Applications**

$\mathbf{F}_B = q\mathbf{v} \times \mathbf{B} = qvB\sin(\theta)$	<p>The force due to a magnetic field on a moving particle depends on the charge and speed of the particle. The direction is given by RHR #2. If <math>v</math> and <math>B</math> are not perpendicular, but instead separated by an angle <math>\theta</math>, use the second formula.</p>
	<p><i>If a positively charged particle is moving to the right, and it enters a magnetic field pointing towards the top of your page, it feels a force going out of the page.</i></p>
	<p><i>Use this figure to remember the geometry of the angle <math>\theta</math>.</i></p>
	<p><i>If a positively charged particle is moving to the left, and it enters a magnetic field pointing towards the top of your page, it feels a force going into the page.</i></p>
$\mathbf{F}_{\text{wire}} = L(\mathbf{I} \times \mathbf{B}) = LIB\sin(\theta)$	<p>A current-carrying wire is made up of a whole bunch of individually moving charges. Thus this wire will feel a force. In this equation, <math>L</math></p>

	refers to the length of the wire.
$\mu_0 = 4\pi \times 10^{-7} \text{ T}\cdot\text{m/A}$	Permeability of a Vacuum( approximately same for air also)
$B_{\text{wire}} = \mu_0 I / 2 \pi r$	The magnetic field generated by a current-carrying wire depends on the strength of the current and the distance from the wire.

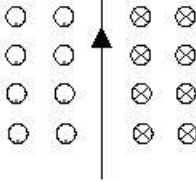
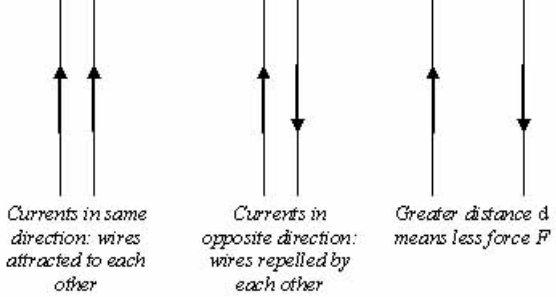
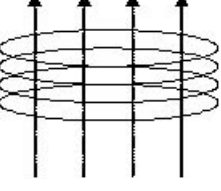
	<p>In the example to the left, a current is running along a wire towards the top of your page. The magnetic field is circling the wire in loops that are pierced through the center by the current. Where these loops intersect this piece of paper, we use the symbol <math>\odot</math> to represent where the magnetic field is coming “out of the page” and the symbol <math>\otimes</math> to represent where the magnetic field is going “into the page.” The distance <math>r</math> (for radius) is the distance from the wire.</p>
<p>Two current-carrying wires next to each other each exert magnetic fields and thereby forces on each other.</p>	
<p><math>\Phi = NB \cdot A</math></p>	<p>If you have a closed, looped wire of area <math>A</math> (measured in <math>\text{m}^2</math>) and <math>N</math> loops, and you pass a magnetic field <math>B</math> through, the magnetic flux is <math>\Phi</math>. The units of magnetic flux are <math>\text{T}\cdot\text{m}^2</math>, also known as a <i>Weber</i>(Wb).</p>
	<p>In the example to the left, there are four loops of wire (<math>N = 4</math>) and each has area <math>\pi r^2</math>. The magnetic field is pointing toward the top of the page, at a right angle to the loops. Think of the magnetic flux as the “bundle” of magnetic field lines “held” by the loop. Why does it matter? See the next equation</p>
<p><math>\varepsilon = - \Delta\Phi / \Delta t</math></p>	<p>The direction of the induced current is determined as follows: the current will flow so as to generate a magnetic field that <i>opposes</i> the change in flux. This is called Lenz’s Law.</p> <p>If you change the amount of magnetic flux that is passing through a loop of wire, electrons in the wire will feel a force, and this will generate a current. The equivalent <i>voltage</i> <math>\varepsilon</math> that they feel is equal to the change in flux <math>\Delta\Phi</math> divided by the amount of time <math>\Delta t</math> it takes to change the flux by that amount. This is Faraday’s Law of Induction</p>

### Magnetism Problem Set

1. Can you set a resting electron into motion with a stationary magnetic field? With an electric field? Explain.
2. How is electrical energy produced in a dam using a hydroelectric generator? Explain in a short essay involving as many different ideas from physics as you need.
3. A speaker consists of a diaphragm (a flat plate), which is attached to a magnet. A coil of wire surrounds the magnet. How can an electrical current be transformed into sound? Why is a coil better than a single loop? If you want to make music, what should you do to the current?

4. For each of the arrangements of velocity  $\mathbf{v}$  and magnetic field  $\mathbf{B}$  below, determine the direction of the force. Assume the moving particle has a positive charge.

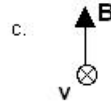
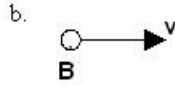
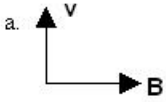

5. Sketch the magnetic field lines for the horseshoe magnet shown here. Then, show the direction in which the two compasses (shown as circles) should point considering their positions. In other words, draw an arrow in the compass that represents North in relation to the compass magnet.

6. As an electron that is traveling in the positive  $x$ -direction encounters a magnetic field, it begins to turn in the upward direction (positive  $y$ -direction). What is the direction of the magnetic field?

- " $x$ "-direction
- " $y$ "-direction (towards the top of the page)
- " $z$ "-direction (i.e. into the page)
- " $z$ "-direction (i.e. out of the page)
- none of the above

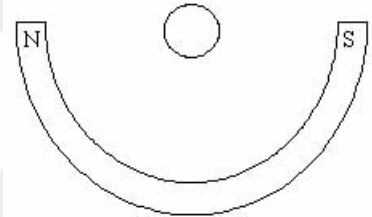

7. A positively charged hydrogen ion turns upward as it enters a magnetic field that points into the page. What direction was the ion going before it entered the field?

- " $x$ "-direction
- " $x$ "-direction
- " $y$ "-direction (towards the bottom of the page)
- " $z$ "-direction (i.e. out of the page)
- none of the above

8. An electron is moving to the east at a speed of  $1.8 \times 10^6$  m/s. It feels a force in the upward direction with a magnitude of  $2.2 \times 10^{-12}$  N. What is the magnitude and direction of the magnetic field this electron just passed through?

9. A vertical wire, with a current of 6.0 A going towards the ground, is immersed in a magnetic field of 5.0 T pointing to the right. What is the value and direction of the force on the wire? The length of the wire is 2.0 m.

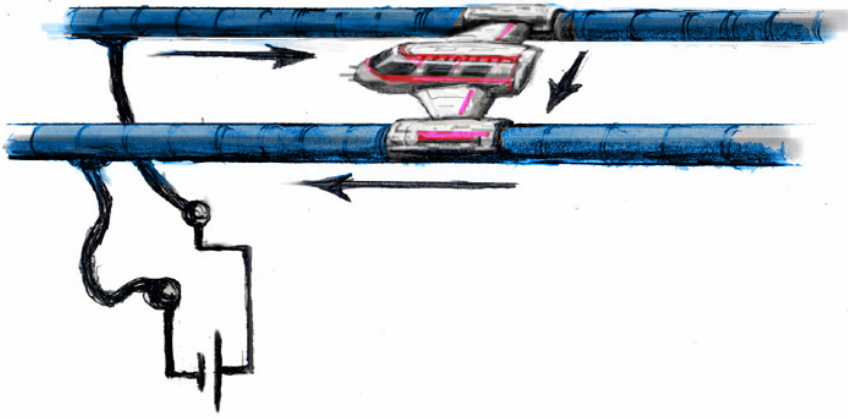

10. A futuristic magneto-car uses the interaction between current flowing across the magneto car and magnetic fields to propel itself forward. The device consists of two fixed metal tracks and a freely moving metal car (see illustration above). A magnetic field is pointing downward with respect to the car, and has the strength of 5.00 T. The car is 4.70 m wide and has 800 A of current flowing through it. The arrows indicate the direction of the current flow.

- Find the direction and magnitude of the force on the car.
- If the car has a mass of 2050 kg, what is its velocity after 10 s, assuming it starts at rest?
- If you want double the force for the same magnetic field, how should the current change?

11. A horizontal wire carries a current of 48 A towards the east. A second wire with mass 0.05 kg runs parallel to the first, but lies 15 cm below it. This second wire is held in suspension by the magnetic field of the first wire above it. If each wire has a length of half a meter, what is the magnitude and direction of the current in the lower wire?

12. Protons with momentum  $5.1 \times 10^{-20}$  kg·m/s are magnetically steered clockwise in a circular path. The path is 2.0 km in diameter. (This takes place at the Dann International Accelerator Laboratory, to be built in 2057 in San Francisco.) Find the magnitude and direction of the magnetic field acting on the protons.

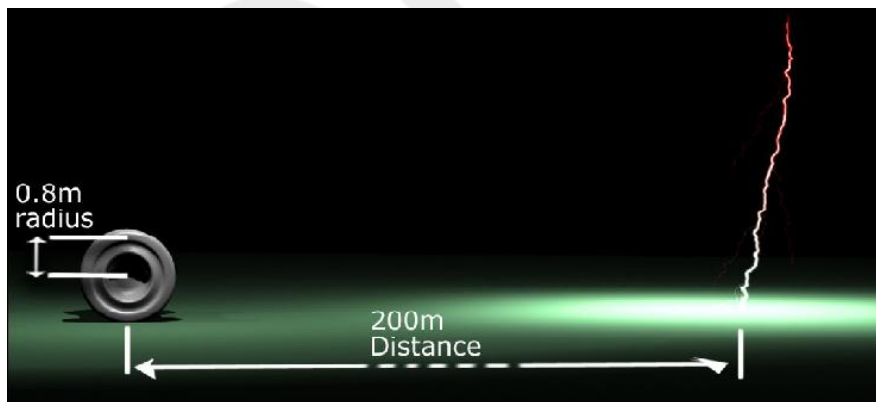

13. A bolt of lightning strikes the ground 200 m away from a 100-turn coil (see above). If the current in the lightning bolt falls from  $6.0 \times 10^6$  A to 0.0 A in 10 ms, what is the average *voltage*,  $\epsilon$ , induced in the coil? What is the *direction* of the induced current in the coil? (Is it clockwise or counterclockwise?) Assume that the distance to the center of the coil determines the average magnetic induction at the coil's position. Treat the lightning bolt as a vertical wire with the current flowing toward the ground.

14. A coil of wire with 10 loops and a radius of 0.2 m is sitting on the lab bench with an electro-magnet facing into the loop. For the purposes of your sketch, assume the magnetic field from the electromagnet is pointing out of the page. In 0.035 s, the magnetic field drops from 0.42 T to 0 T.

- What is the voltage induced in the coil of wire?
- Sketch the direction of the current flowing in the loop as the magnetic field is turned off. (Answer as if you are looking down at the loop).

15. A wire has 2 A of current flowing in the upward direction.

- What is the value of the magnetic field 2 cm away from the wire?
- Sketch the direction of the magnetic field lines in the picture to the right.
- If we turn on a magnetic field of 1.4 T, pointing to the right, what is the value and direction of the force per meter acting on the wire of current?
- Instead of turning on a magnetic field, we decide to add a loop of wire (with radius 1 cm) with its center 2 cm from the original wire. If we then increase the current in the straight wire by 3 A per second, what is the direction of the induced current flow in the loop of wire?

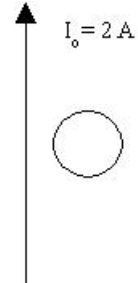

16. An electron is accelerated from rest through a potential difference of  $1.67 \times 10^5$  volts. It then enters a region traveling perpendicular to a magnetic field of 0.25 T.

- Calculate the velocity of the electron.
- Calculate the magnitude of the magnetic force on the electron.
- Calculate the radius of the circle of the electron's path in the region of the magnetic field

17. A beam of charged particles travel in a straight line through mutually perpendicular electric and magnetic fields. One of the particles has a charge,  $q$ ; the magnetic field is  $B$  and the electric field is  $E$ . Find the velocity of the particle.

18. Two long thin wires are on the same plane but perpendicular to each other. The wire on the  $y$ -axis carries a current of 6.0 A in the  $-y$  direction. The wire on the  $x$ -axis carries a current of 2.0 A in the  $+x$  direction. Point,  $P$  has the co-ordinates of (2.0, 2.0) in meters. A charged particle moves in a direction of  $45^\circ$  away from the origin at point,  $P$ , with a velocity of  $1.0 \times 10^7$  m/s.

- Find the magnitude and direction of the magnetic field at point,  $P$ .
- If there is a magnetic force of  $1.0 \times 10^{-6}$  N on the particle determine its charge.
- Determine the magnitude of an electric field that will cancel the magnetic force on the particle.

19. A rectangular loop of wire 8.0 m long and 1.0 m wide has a resistor of  $5.0 \Omega$  on the 1.0 side and moves out of a 0.40 T magnetic field at a speed of 2.0 m/s in the direction of the 8.0 m side.

- Determine the induced voltage in the loop.
- Determine the direction of current.
- What would be the net force needed to keep the loop at a steady velocity?
- What is the electric field across the .50 m long resistor?
- What is the power dissipated in the resistor?



20. A positron (same mass, opposite charge as an electron) is accelerated through 35,000 volts and enters the center of a 1.00 cm long and 1.00 mm wide capacitor, which is charged to 400 volts. A magnetic field is applied to keep the positron in a straight line in the capacitor. The same field is applied to the region (region II) the positron enters after the capacitor.

- a. What is the speed of the positron as it enters the capacitor?
- b. Show all forces on the positron.
- c. Prove that the force of gravity can be safely ignored in this problem.
- d. Calculate the magnitude and direction of the magnetic field necessary.
- e. Show the path and calculate the radius of the positron in region II.
- f. Now the magnetic field is removed; calculate the acceleration of the positron away from the center.
- g. Calculate the angle away from the center with which it would enter region II if the magnetic field were to be removed.

21. A small rectangular loop of wire 2.00 m by 3.00 m moves with a velocity of 80.0 m/s in a non-uniform field that diminishes in the direction of motion uniformly by .0400 T/m. Calculate the induced emf in the loop. What would be the direction of current?

22. An electron is accelerated through 20,000 V and moves along the positive x-axis through a plate 1.00cm wide and 2.00 cm long. A magnetic field of 0.020 T is applied in the -z direction.

- a. Calculate the velocity with which the electron enters the plate.
- b. Calculate the magnitude and direction of the magnetic force on the electron.
- c. Calculate the acceleration of the electron.
- d. Calculate the deviation in the y direction of the electron from the center.
- e. Calculate the electric field necessary to keep the electron on a straight path.
- f. Calculate the necessary voltage that must be applied to the plate.

23. A long straight wire is on the x-axis and has a current of 12 A in the  $-x$  direction. A point P, is located 2.0 m above the wire on the y-axis.

- a. What is the magnitude and direction of the magnetic field at P.
- b. If an electron moves through P in the  $-x$  direction at a speed of  $8.0 \times 10^7$  m/s what is the magnitude and direction of the force on the electron?
- c. What would be the magnitude and direction of an electric field to be applied at P that would counteract the magnetic force on the electron?

# 16. Electric Circuits:Capacitors

AUTHOR: James H. Dann, Ph.D., James J. Dann SOURCE: The People's Physics Book LICENSE: CCSA

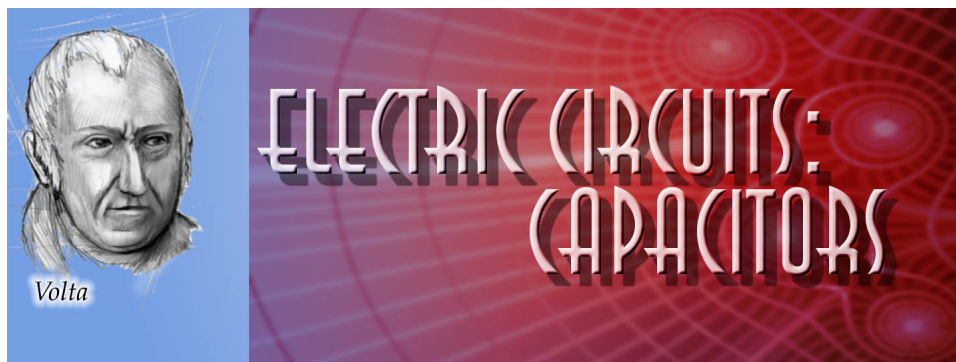

## The Big Idea

When current flows through wires and resistors in a circuit as a result of an electric potential, charge does not build up significantly anywhere on the path. Capacitors are devices placed in electric circuits where charge *can* build up. The amount of charge a capacitor can store before it “fills up” depends on its shape and how much electric potential is applied. The larger the electric potential in volts, the stronger the electric field that is used to “cram” the charge into the device. Eventually, all capacitors fill up when you put enough charge in them. This can be a way to store energy ... by *discharging* the capacitor, you release the stored charge to flow and do your bidding.

## Key Equations

$Q = CV$	the charge stored in a capacitor is equal to the capacitance multiplied by the electric potential. C is measured in farads (F).
$U = \frac{1}{2}CV^2$	the potential energy stored in a capacitor is equal to one half the stored charge multiplied by the electric potential squared. U is measured in joules.
$C = \kappa\epsilon_0 A/d$	the capacitance of two parallel metal plates of area A, separated by distance d, and filled with a substance with dielectric constant $\kappa$ is given by this formula. $\epsilon_0 = 8.85 \times 10^{-12} \text{ C}^2/\text{Nm}^2$ is a constant of nature, called the permittivity.
$Q = Q_0 e^{-t/\tau}$	where $\tau = RC$ . The amount of time, t, it takes to charge or discharge about 2/3 ( $1 - 1/e$ ) of a capacitor is equal to the product of the resistor through which you are running current times the capacitance of the capacitor.

## Electric Circuit Symbol



The symbol for a capacitor is two flat plates, mimicking the geometry of a capacitor, which typically consists of two flat plates separated by a small distance. The plates are normally wrapped around several times to form a cylindrical shape.

### Key Concepts

- Current can flow *into* a capacitor from either side, but current doesn't flow across the capacitor from one plate to another. The plates do not touch, and the substance in between is insulating, not conducting.
- One side of the capacitor fills up with negative charge, and the other fills up with positive charge. The reason for the thin, close plates is so that you can use the negative charge on one plate to attract and hold the positive charge on the other plate. The reason for the plates with large areas is so that you can spread out the charge on one plate so that its self-repulsion doesn't stop you from filling it with more charge.
- Typical dielectric constants  $\kappa$  are roughly 5.6 for glass and 80 for water. What these "dielectric" substances do is align their electric polarity with the electric field in a capacitor (much like atoms in a magnetic material) and, in doing so, amplify the electric field, allowing more charge to be stored without repelling.
- When a capacitor is initially uncharged, it is very easy to stuff charge in. As you put more charge in, it starts to build up and repel the additional charge you are attempting to stuff in there. The charging of a capacitor follows a logarithmic curve. The total amount of energy you need to expend to fully charge a capacitor with charge  $Q$  and electric potential  $V$  is  $U = \frac{1}{2}QV = \frac{1}{2}CV^2$ . When you pass current through a resistor into a capacitor, the capacitor eventually "fills up" and no more current flows. A typical RC circuit is shown below; when the switch is closed, the capacitor discharges with an exponentially decreasing current.

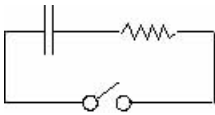

- $Q$  refers to the amount of positive charge stored on the high voltage side of the capacitor; an equal and opposite amount,  $-Q$ , of negative charge is stored on the low voltage side of the capacitor.
- The total capacitance of two or more capacitors placed in series add as resistors *in parallel*:  $1 / C_s = 1/C_1 + 1/C_2 \dots$ ; two or more capacitors wired in parallel add as resistors *in series*:  $C_p = C_1 + C_2 \dots$
- Many home-electronic circuits include capacitors; for this reason, it can be dangerous to mess around with old electronic components, as the capacitors may be charged even if the unit is unplugged. For example, old computer monitors (not flat screens) and TVs have capacitors that hold dangerous amounts of charge hours after the power is turned off.

### Chapter 15: Electric Circuits – Capacitors Problems

1. Design a parallel plate capacitor with a capacitance of 100 mF. You can select any area, plate separation, and dielectric substance that you wish.
2. You have a 5  $\mu$ F capacitor.
  - a. How much voltage would you have to apply to charge the capacitor with 200 C of charge?
  - b. Once you have finished, how much potential energy are you storing here?
  - c. If all this energy could be harnessed to lift you up into the air, how high would you be lifted?

3. Show, by means of a sketch illustrating the charge distribution, that two identical parallel-plate capacitors wired in parallel act exactly the same as a single capacitor with twice the area.

4. A certain capacitor can store 5 C of charge if you apply a voltage of 10 V.

a. How many volts would you have to apply to store 50 C of charge in the same capacitor?

b. Why is it harder to store more charge?

5. A certain capacitor can store 500 J of energy (by storing charge) if you apply a voltage of 15 V. How many volts would you have to apply to store 1000 J of energy in the same capacitor? (Important: why isn't the answer to this just 30 V?)

6. Marciel, a bicycling physicist, wishes to harvest some of the energy he puts into turning the pedals of his bike and store this energy in a capacitor. Then, when he stops at a stop light, the charge from this capacitor can flow out and run his bicycle headlight. He is able to generate 18 V of electric potential, on average, by pedaling (and using magnetic induction).

a. If Mars wants to provide 0.5 A of current for 60 seconds at a stop light, how big a 18V capacitor should he buy (i.e. how many farads)?

b. How big a resistor should he pass the current through so the RC time is three minutes?

7. Given a capacitor with 1 cm between the plates a field of 20,000 N/C is established between the plates.

a. What is the voltage across the capacitor?

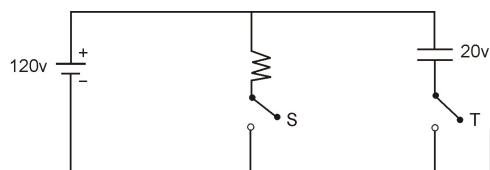

b. If the charge on the plates is 1  $\mu\text{C}$ , what is the capacitance of the capacitor?

c. If two identical capacitors of this capacitance are connected in series what is the total capacitance?

d. Consider the capacitor connected in the following circuit at point B with two switches S and T, a 20  $\Omega$  resistor and a 120 V power source:

i. Calculate the current through and the voltage across the resistor if S is open and T is closed

ii. Repeat if S is closed and T is open

Figure for Problems 8-10:

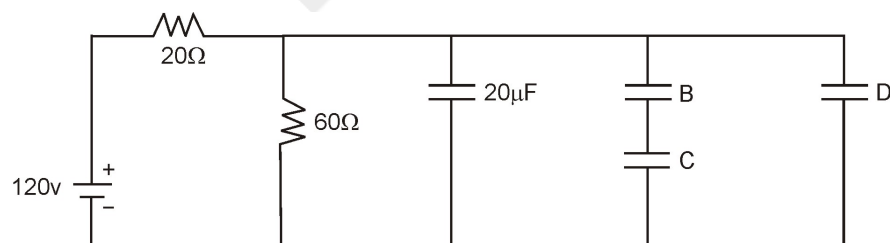

8. Consider the figure above with switch, S, initially open:

a. What is the voltage drop across the 20  $\Omega$  resistor?

- b. What current flows thru the  $60\ \Omega$  resistor?
- c. What is the voltage drop across the  $20\ \mu\text{F}$  capacitor?
- d. What is the charge on the capacitor?
- e. How much energy is stored in that capacitor?
- f. Find the capacitance of capacitors B, C, and D if compared to the  $20\ \mu\text{F}$  capacitor where...
- B has twice the plate area and half the plate separation
  - C has twice the plate area and the same plate separation
  - D has three times the plate area and half the plate separation
9. Now the switch in the previous problem is closed.
- What is the total capacitance of branch II?
  - What is the total capacitance of branches I, II, and III taken together?
  - What is the voltage drop across capacitor B?
10. Reopen the switch in the previous problem and look at the  $20\ \mu\text{F}$  capacitor. It has a plate separation of  $2.0\ \text{mm}$ .
- What is the magnitude and direction of the electric field?
  - If an electron is released in the center to traverse the capacitor and given a speed  $\frac{2}{3}$  the speed of light parallel to the plates, what is the magnitude of the force on that electron?
  - What would be its acceleration in the direction perpendicular to its motion?
  - If the plates are  $1.0\ \text{cm}$  long, how much time would it take to traverse the plate?
  - What displacement toward the plates would the electron undergo?
  - With what angle with respect to the direction of motion does the electron leave the plate?
11. Design a circuit that uses capacitors, switches, voltage sources, and light bulbs that will allow the interior lights of your car to dim slowly once you get out.
12. Design a circuit that would allow you to determine the capacitance of an unknown capacitor.
13. The voltage source in the circuit below provides  $10\ \text{V}$ . The resistor is  $200\ \Omega$  and the capacitor has a value of  $50\ \mu\text{F}$ . What is the voltage across the capacitor after the circuit has been hooked up for a long time?

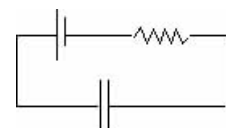

# 17. Electric Circuits Advanced Topics

AUTHOR: James H. Dann, Ph.D., James J. Dann SOURCE: The People's Physics Book LICENSE: CCSA

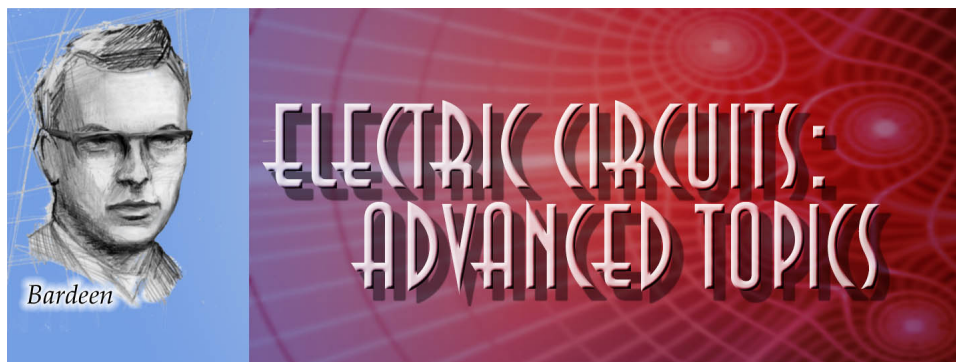

## The Big Idea

Modern circuitry depends on much more than just resistors and capacitors. The circuits in your computer, cell phone, and iPod depend on circuit elements called diodes, inductors, transistors, and operational amplifiers, as well as on other chips. In particular the invention of the transistor made the small size of modern devices possible. Transistors and op amps are known as *active* circuit elements. An active circuit element needs an external source of power to operate. This differentiates them from diodes, capacitors, inductors and resistors, which are *passive* elements.

## Key Concepts

- *Inductors* are made from coiled wires, normally wrapped around ferromagnetic material and operate according to the principles of magnetic induction presented in Magnetism. Inductors generate a *back-emf*. Back-emf is essentially an induced negative voltage which opposes changes in current. The amount of back-emf generated is proportional to how quickly the current changes. They can be thought of as automatic flow regulators that oppose any change in current. Thus electrical engineers call them *chokes*.

	In a circuit diagram, an inductor looks like a coil. The resistance $R$ and capacitance $C$ of an inductor are very close to zero. When analyzing a circuit diagram, assume $R$ and $C$ are precisely zero.
---	---





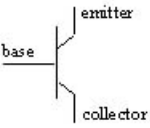

- *Diodes* are passive circuit elements that act like one-way gates. Diodes allow current to flow one way, but not the other. For example, a diode that “turns on” at 0.6 V acts as follows: if the voltage drop across the diode is less than 0.6 V, no current will flow. Above 0.6 V, current flows with essentially no resistance. If the voltage drop is negative (and not extremely large), no current will flow.

	Diodes have an arrow showing the direction of the flow.
---	---

- *Transistors* are active circuit elements that act like control gates for the flow of current. Although there are many types of transistors, let's consider just one kind for now. This type of transistor has three electrical leads: the base, the emitter, and the collector.

	<p>The voltage applied to the base controls the amount of current which flows from the emitter to the collector.</p>
---	--



- For example, if the base voltage is more than 0.8 V above the collector voltage, then current can freely flow from the emitter to the collector, as if it were just a wire. If the base voltage is less than 0.8 V above the collector voltage, then current does not flow from the emitter to the collector. Thus the transistor acts as a switch. (This 0.8 V is known as a “diode drop” and varies from transistor to transistor.)
- Transistors have an infinite *output resistance*. If you measure the resistance between the collector and the base (or between the emitter and the base), it will be extremely high. Essentially no current flows into the base from either the collector or the emitter; any current, if it flows, flows from the emitter to the collector..
- Transistors are used in *amplifier* circuits, which take an input voltage and magnify it by a large factor. Amplifiers typically run on the principle of positive and negative *feedback*. Feedback occurs when a small portion of an output voltage is used to influence the input voltage.

Circuit element	Symbol	Electrical symbol	Unit	Everyday device
Voltage Source	$\Delta V$		Volts (V)	Batteries, electrical outlets, power stations
Resistor	<b>R</b>		Ohm ( $\Omega$ )	Light bulbs, toasters, hair dryers
Capacitor	<b>C</b>		Farad (F)	Computer keyboards, timers
Inductor	<b>L</b>		Henry (H)	Electronic chokes, AC transformers
Diode	varies by type		none	Light-emitting diodes (LEDs)
Transistor	varies by type		none	Computer chips, amplifiers

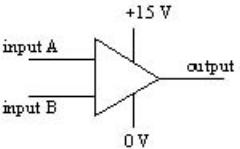
- An *operational amplifier* or op-amp is an active circuit element that performs a specific function. The most common op-amp has five leads: two input leads, one output lead, and two fixed-voltage leads.

	<p>The job of an op-amp is to use the voltage it is supplied to adjust its output voltage. The op-amp will adjust its output voltage until the two input voltages are brought closer together. In other words, the output voltage will change as it needs to until <math>V_A - V_B = 0</math>. This won't happen unless the output voltage is somehow “fed back” into one of the inputs</p>
---	---

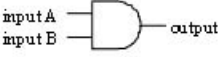
- *Digital circuits* only care about two voltages: for example, +5 V (known as “on”) and 0 V (known as “off”).
- *Logic devices*, which are active circuit elements, interpret voltages according to a simple set of mathematical rules known as Boolean logic. The most basic logic devices are the AND, OR, and NOT gates:

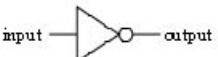
	<p>For an AND gate, the output will always be at an electric potential of 0 V (off) unless <i>both</i> the inputs are at 5 V (on), in which case the output will be at 5 V (on) as well.</p>
	<p>For an OR gate, the output will always be at an electric potential of 0 V (off) unless <i>either</i> of the inputs are at 5 V (on), in which case the output will be at 5 V (on) as well.</p>
	<p>For a NOT gate, the output will always be the <i>opposite</i> of the input. Thus, if the input is 5 V (on), the output will be 0 V (off) and vice-versa.</p>

- *Alternating current* changes direction of current flow. The frequency is the number of times the current reverses direction in a second. Household AC is 60 Hz. In AC circuits the current is impeded but not stopped by elements like capacitors and inductors.
- *Capacitive Reactance* is a measure of how a capacitor impedes the current flow from a given voltage in an AC circuit and is inversely proportional to capacitance. *Inductive Reactance* is a measure of how an inductor in an AC circuit impedes the current flow from a given voltage and is directly proportional to inductance.
- *The total impedance of an AC circuit* depends on resistance, capacitive reactance and inductive reactance.
- If the capacitive reactance and inductive reactance are both zero or unequal the voltage and current are *out of phase*. That is they peak at different times in the cycle. The *phase angle* measures the lag or lead of current over voltage.

### Key Equations

$\text{Emf} = -L(\Delta I/\Delta t)$	the emf across an inductor is proportional to the rate of change of the current through it; the emf is negative, meaning that it opposes current flow.
$L = \mu_0 N^2 A/l$	the inductance of a solenoid depends on the number of turns in the solenoid, the cross-sectional area, and the length; the SI unit of inductance is the Henry (H).
$X_L = \omega l$	the inductive reactance equals the inductance times $\omega$ where $\omega = 2\pi f$
$X_C = 1/\omega C$	the capacitive reactance is the reciprocal of $\omega C$
$Z = \sqrt{R^2 + (X_L - X_C)^2}$	the impedance of an AC circuit is given by the Pythagorean Theorem, when R and $X_L - X_C$ are plotted on opposite axes.
$V_m = \text{Im}Z$	Ohm's Law for AC circuits; relating the peak voltages and currents
$\tan\phi = X_L - X_C / R$	formula for the phase angle between peak currents and voltages

### Advanced Topics Problem Set

1. You purchase a circular solenoid with 100 turns, a radius of 0.5 cm, and a length of 2.0 cm.
  - a. Calculate the inductance of your solenoid in Henrys.



b. A current of 0.5 A is passing through your solenoid. The current is turned down to zero over the course of 0.25 seconds. What voltage is induced in the solenoid?

2. What is the voltage drop across an inductor if the current passing through it is not changing with time? Does your answer depend on the physical makeup of the inductor? Explain.

3. Consider the transistor circuit diagram shown here. The resistor is a light bulb that shines when current passes through it.

- If the base is raised to a voltage of 5 V, will the light bulb shine?
- If the base is lowered to a voltage of 0 V, will the light bulb shine?
- Why are transistors sometimes called electronic switches?

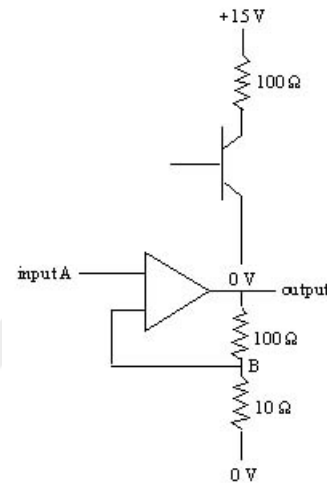

4. Consider the op-amp circuit diagram shown here. Note the fixed-voltage leads are omitted for clarity. (This is typical.)

Let's begin with an input voltage at point A of 0.5 V.

- If the op-amp is "doing its job," what is the electric potential at point B?
- What current is flowing through the 10 Ω resistor?
- Recall that no current ever flows *into* an op-amp. What current must be flowing through the 100 Ω resistor?
- What *must* the output voltage be?

Now let's adjust the input voltage at point A to 0.75 V.

- What is the output voltage now?
- By what factor is the op-amp amplifying the input voltage?
- What are some practical applications for such a device?

5. Consider the logic circuit shown here.

- If A, B, and C are all off, what is the state of D?
- If A, B, and C are all on, what is the state of D?
- Fill out the entire "logic table" for this circuit.

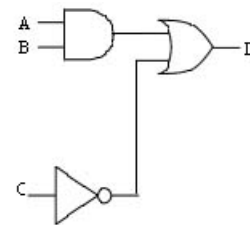

State of A	State of B	State of C	State of D
on	on	on	
on	on	off	
on	off	on	
on	off	off	
off	on	on	
off	off	on	
off	on	off	
off	off	off	

6. A series circuit contains the following elements: a  $125\ \Omega$  resistor, a  $175\ \text{mH}$  inductor, two  $30.0\ \mu\text{F}$  capacitors and a  $40.0\ \mu\text{F}$  capacitor. Voltage is provided by a  $235\ \text{V}_m$  generator operating at  $75.0\ \text{Hz}$ .

- a. Draw a schematic diagram of the circuit.
- b. Calculate the total capacitance of the circuit.
- c. Calculate the capacitive reactance.
- d. Calculate the impedance.
- e. Calculate the peak current.
- f. Calculate the phase angle.
- g. Resonance occurs at the frequency when peak current is maximized. What is that frequency?

DRAFT

# 18. Light

AUTHOR: James H. Dann, Ph.D., James J. Dann SOURCE: The People's Physics Book LICENSE: CCSA



## The Big Idea

Light is a *wave* of changing electric and magnetic fields. Light waves are caused by disturbances in the electromagnetic field, for example, the acceleration of charged particles (such as electrons). Light has a dual nature; at times, it acts like waves, while at other times it acts like particles, called *photons*. Light travels through space at the maximum speed allowed by the laws of physics, called the speed of light. Light has no mass, but it carries energy and momentum. Of all possible paths, *light will always take the path that takes the least amount of time* (not distance). This is known as Fermat's Principle.

Fermat's Principle governs the paths light will take and explains the familiar phenomena of reflection, refraction, diffraction, scattering and color absorption and dispersion. Light rarely travels in a straight line path. When photons interact with electrons in matter, the time it takes for this interaction determines the path. For example, higher frequency blue light is refracted more than red because blue interacts more frequently with electrons than red. Also, the path of least time is achieved when blue light bends more than red light so that it gets out of the 'slow' region faster. The rainbows we see are a result of this. Fermat's Principle explains the many fascinating phenomena of light from rainbows to sunsets to the halos around the moon.

## Key Concepts

- Light is produced when charged particles *accelerate*. As a result, changing electric and magnetic fields radiate outward. The traveling electric and magnetic fields of an accelerating (often oscillating) charged particle are known as electromagnetic radiation or light.
- The color of light that we observe is nothing more than the wavelength of the light: the *longer* the wavelength, the *redder* the light.
- The spectrum of electromagnetic radiation can be roughly broken into the following ranges:

EM wave	Wavelength range	Comparison size
---------	------------------	-----------------

gamma-ray ( $\gamma$ -ray)	$10^{-11}$ m and shorter	atomic nucleus
x-ray	$10^{-11}$ m – $10^{-8}$ m	hydrogen atom
ultraviolet (UV)	$10^{-8}$ m – $10^{-7}$ m	small molecule
violet (visible)	$\sim 4 \times 10^{-7}$ m (400 nm)*	typical molecule
blue (visible)	$\sim 450$ nm	typical molecule
green (visible)	$\sim 500$ nm	typical molecule
red (visible)	$\sim 650$ nm	typical molecule
infrared (IR)	$10^{-6}$ m – 1 mm	human hair
microwave	1 mm – 10 cm	human finger
radio	Larger than 10 cm	car antenna

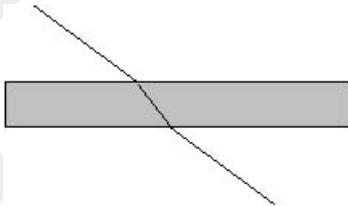
- Light can have any wavelength at all. Our *vision* is restricted to a very narrow range of colors between red and violet.
- Fermat's Principle makes the angle of incident light equal to the angle of reflected light. This is the *law of reflection*.
- When light travels from one type of material (like air) into another (like glass), the speed slows down due to interactions between photons and electrons. If the ray enters the material at an angle, Fermat's Principle dictates that the light also changes the direction of its motion. This is called *refraction*. See figure at right which demonstrates the refraction a light ray experiences as it passes from air into a rectangular piece of glass and out again. Because light travels at slower than usual speed in transparent materials (due to constantly being absorbed and re-emitted), this means that light doesn't always travel in a straight line.
 
- White light consists of a mixture of all the visible colors: red, orange, yellow, green, blue, indigo, and violet (ROYGBIV). Our perception of the color black is tied to the *absence* of light.
- Our eyes include color-sensitive and brightness-sensitive cells. The three different color-sensitive cells (cones) can have sensitivity in three colors: red, blue, and green. Our perception of other colors is made from the *relative amounts* of each color that the cones register from light reflected from the object we are looking at. Our brightness-sensitive cells work well in low light. This is why things look 'black and white' at night.
- The chemical bonds in pigments and dyes – like those in a colorful shirt – absorb light at frequencies that correspond to certain colors. When you shine white light on these pigments and dyes, some colors are absorbed and some colors are reflected. We only see the colors objects *reflect*.

## Color Addition

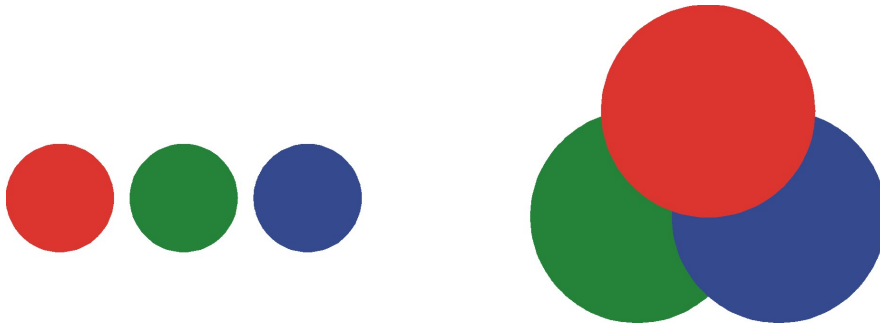

Red	Green	Blue	Perceived color
√	√	√	white
			black
√		√	magenta
√	√		yellow
	√	√	cyan

### Key Applications

- *Total internal reflection* occurs when light goes from a slow (high index of refraction) medium to a fast (low index of refraction) medium. With total internal reflection, light refracts so much it actually refracts back into the first medium. This is how fiber optic cables work: no light leaves the wire.
- *Rayleigh scattering* occurs when light interacts with our atmosphere. The shorter the wavelength of light, the more strongly it is disturbed by collisions with atmospheric molecules. So Fermat's Principle dictates that blue light from the Sun is preferentially *scattered* by these collisions into our line of sight. This is why the sky appears blue.
- *Beautiful sunsets* occur when light travels long distances through the atmosphere. The blue light and some green is scattered away, making the sun appear red.
- *Lenses*, made from curved pieces of glass, focus or de-focus light as it passes through. Lenses that focus light are called *converging* lenses, and these are the ones used to make telescopes and cameras. Lenses that de-focus light are called *diverging* lenses.
- Lenses can be used to make visual representations, called *images*.
- *Mirrors* are made from highly reflective metal that is applied to a curved or flat piece of glass. Converging mirrors can be used to focus light – headlights, telescopes, satellite TV receivers, and solar cookers all rely on this principle. Like lenses, mirrors can create images.
- The *focal length*,  $f$ , of a lens or mirror is the distance from the surface of the lens or mirror to the place where the light is focused. This is called the *focal point* or *focus*. For diverging lenses or mirrors, the focal length is negative.
- When light rays converge in front of a mirror or behind a lens, a *real* image is formed. Real images are useful in that you can place photographic film at the physical location of the real image, expose the film to the light, and make a two-dimensional representation of the world, a photograph.



Converging lens



Diverging lens

- When light rays diverge in front of a mirror or behind a lens, a *virtual* image is formed. A virtual image is a trick, like the person you see “behind” a mirror’s surface when you brush your teeth. Since virtual images aren’t actually “anywhere,” you can’t place photographic film anywhere to capture them.
- Real images are upside-down, or *inverted*. You can make a real image of an object by putting it farther from a mirror or lens than the focal length. Virtual images are typically right-side-up. You can make virtual images by moving the mirror or lens closer to the object than the focal length.

- Waves are characterized by their ability to constructively and destructively *interfere*. Light waves which interfere with themselves after interaction with a small aperture or target are said to *diffract*.
- Light creates interference patterns when passing through holes (“slits”) in an obstruction such as paper or the surface of a CD, or when passing through a thin film such as soap.

### Key Equations

$\lambda f = c$	The product of the wavelength $\lambda$ of the light (in meters) and the frequency $f$ of the light (in Hz, or 1/sec) is always equal to a constant, namely the speed of light $c = 300,000,000$ m/s.
$n = c / u$	The index of refraction, $n$ , is the ratio of the the speed $c$ it travels in a vacuum to the slower speed it travels in a material. $n$ can depend slightly on wavelength.
$n_i \sin(\theta_i) = n_r \sin(\theta_r)$	
$m\lambda = d\sin(\theta)$ double slit interference	$m$ is an integer counting up to the number of interference maxima in question, $d$ is the distance between slits (double-slit interference.) and $\theta$ is the angular separation of the maximum.
$m\lambda = d\sin\theta$ single slit diffraction	$m$ and $\theta$ are defined as above and $d$ is the width of the slit.
$m\lambda = d\sin\theta$ diffraction grating	$m$ and $\theta$ are defined as above and $d$ is the distance between the lines on the grating.
$m\lambda = 2nd$	Thin film interference: $n$ is the index of refraction of the film, $d$ is the thickness of the film, and $m$ is an integer. In the film interference, there is a $\lambda/2$ delay (phase change) if the light is reflected from an object with an index of refraction greater than that of the incident material.
$\frac{1}{f} = \frac{1}{d_o} + \frac{1}{d_i}$	For lenses, the distance from the center of the lens to the focus is $f$ . Focal lengths for foci behind the lens are positive in sign. The distance from the center of the lens to the object in question is $d_o$ , where distances to the left of the lens are positive in sign. The distance from the center of the lens to the image is $d_i$ . This number is positive for real images (formed to the right of the lens), and negative for virtual images

	(formed to the left of the lens). For mirrors, the same equation holds! However, the object and image distances are both positive for real images formed to the left of the mirror. For virtual images formed to the right of the mirror, the image distance is negative
$M = \frac{-d_i}{d_o}$	The size of an object's image is larger (or smaller) than the object itself by its magnification, $M$ . The level of magnification is proportional to the ratio of $d_i$ and $d_o$ . An image that is double the size of the object would have magnification $M = 2$ .
$R = 2f$	The radius of curvature of a mirror is twice its focal length

### Light Problem Set

1. Which corresponds to light of longer wavelength, UV rays or IR rays?
2. Which corresponds to light of lower frequency, x-rays or millimeter-wavelength light?
3. Approximately how many blue wavelengths would fit end-to-end within a space of one millimeter?
4. Approximately how many short ("hard") x-rays would fit end-to-end within the space of a single red wavelength?
5. Calculate the frequency in Hz of a typical green photon emitted by the Sun. What is the physical interpretation of this (very high) frequency? (That is, what is oscillating?)
6. FM radio stations list the frequency of the light they are emitting in MHz, or millions of cycles per second. For instance, 90.3 FM would operate at a frequency of  $90.3 \times 10^6$  Hz. What is the wavelength of the radio-frequency light emitted by this radio station? Compare this length to the size of your car's antenna, and make an argument as to why the length of a car's antenna should be about the wavelength of the light you are receiving.
7. Consult the color table for human perception under the 'Key Concepts' section and answer the questions which follow.
  - a. Your coat looks magenta in white light. What color does it appear in blue light? In green light?
  - b. Which secondary color would look black under a blue light bulb?
  - c. You look at a cyan-colored ribbon under white light. Which of the three primary colors is your eye *not* detecting?
8. Consider the following table, which states the indices of refraction for a number of materials.

Material	n
vacuum	1.00000
air	1.00029
water	1.33
typical glass	1.52
cooking oil	1.53
heavy flint glass	1.65
sapphire	1.77

diamond	2.42
---------	------

- a. For which of these materials is the speed of light *slowest*?
- b. Which two materials have the most similar indices of refraction?
- c. What is the speed of light in cooking oil?
9. A certain light wave has a frequency of  $4.29 \times 10^{14}$  Hz. What is the wavelength of this wave in empty space? In water?
10. A light ray bounces off a fish in your aquarium. It travels through the water, into the glass side of the aquarium, and then into air. Draw a sketch of the situation, being careful to indicate how the light will change directions when it refracts at each interface. Include a brief discussion of why this occurs.
11. Why is the sky blue? Find a family member who doesn't know why the sky is blue and explain it to them. Ask them to write a short paragraph explaining the situation and include a sketch.
12. Describe the function of the dye in blue jeans. What does the dye do to each of the various colors of visible light?
13. A light ray goes from the air into the water. If the angle of incidence is  $34^\circ$ , what is the angle of refraction?
14. In the "disappearing test tube" demo, a test tube filled with vegetable oil vanishes when placed in a beaker full of the same oil. How is this possible? Would a diamond tube filled with water and placed in water have the same effect?
15. Imagine a thread of diamond wire immersed in water. Can such an object demonstrate total internal reflection? If so, what is the critical angle? Draw a picture along with your calculations.
16. A light source sits in a tank of water, as shown.
- a. If one of the light rays coming from inside the tank of water hits the surface at  $35.0^\circ$ , as measured from the normal to the surface, at what angle will it enter the air?
- b. Now suppose the incident angle in the water is  $80^\circ$  as measured from the normal. What is the refracted angle? What problem arises?
- c. Find the *critical angle* for the water-air interface. This is the incident angle that corresponds to the largest possible refracted angle,  $90^\circ$ .

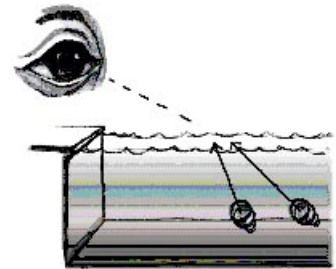



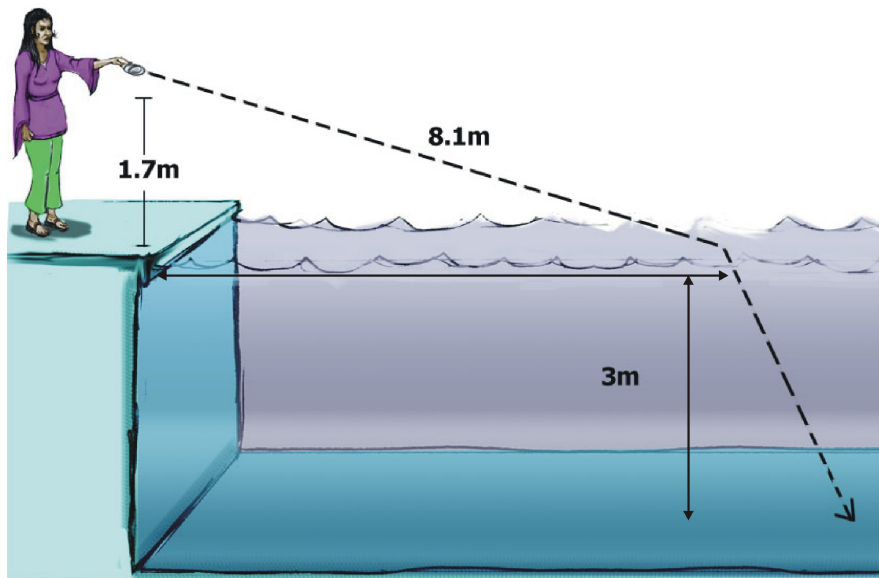

17. Nisha stands at the edge of an aquarium 3.0 m deep. She shines a laser at a height of 1.7 m that hits the water of the pool 8.1 m from the edge.

- Draw a diagram of this situation. Label all known lengths.
- How far from the edge of the pool will the light hit bottom?
- If her friend, James, were at the bottom and shined a light back, hitting the same spot as Nisha's, how far from the edge would he have to be so that the light never leaves the water?

18. Here's an example of the "flat mirror problem." Marjan is looking at herself in the mirror. Assume that her eyes are 10 cm below the top of her head, and that she stands 180 cm tall. Calculate the minimum length flat mirror that Marjan would need to see her body from eye level all the way down to her feet. Sketch at least 3 ray traces from her eyes showing the topmost, bottommost, and middle rays.

*In the following five problems, you will do a careful ray tracing with a ruler (including the extrapolation of rays for virtual images). It is best if you can use different colors for the three different ray tracings. When sketching diverging rays, you should use dotted lines for the extrapolated lines behind a mirror or in front of a lens in order to produce the virtual image. When comparing measured distances and heights to calculated distances and heights, values within 10% are considered "good." Use the following cheat sheet as your guide.*

CONVERGING(CONCAVE)MIRRORS	<p>Ray #1: Leaves tip of candle, travels parallel to optic axis, reflects back through focus.</p> <p>Ray #2: Leaves tip, travels through focus, reflects back parallel to optic axis.</p> <p>Ray #3: Leaves tip, reflects off center of mirror with an angle of reflection equal to the angle of incidence.</p>
DIVERGING (CONVEX) MIRRORS	<p>Ray #1: Leaves tip, travels parallel to optic axis, reflects OUTWARD by lining up with focus on the OPPOSITE side as the candle.</p>

	<p>Ray #2: Leaves tip, heads toward the focus on the OPPOSITE side, and emerges parallel to the optic axis.</p> <p>Ray #3: Leaves tip, heads straight for the mirror center, and reflects at an equal angle.</p>
CONVERGING (CONVEX) LENSES	<p>Ray #1: Leaves tip, travels parallel to optic axis, refracts and travels through to the focus.</p> <p>Ray #2: Leaves tip, travels through focus on same side, travels through lens, and exits lens parallel to optic axis on opposite side.</p> <p>Ray #3: Leaves tip, passes straight through center of lens and exits without bending.</p>
DIVERGING (CONCAVE) LENSES	<p>Ray #1: Leaves tip, travels parallel to optic axis, refracts OUTWARD by lining up with focus on the SAME side as the candle.</p> <p>Ray #2: Leaves tip, heads toward the focus on the OPPOSITE side, and emerges parallel from the lens.</p> <p>Ray #3: Leaves tip, passes straight through the center of lens and exits without bending.</p>

19. Consider a concave mirror with a focal length equal to two units, as shown below.

a. *Carefully* trace three rays coming off the top of the object in order to form the image.

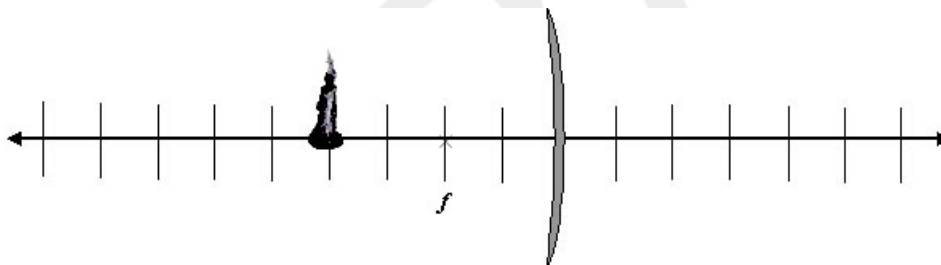

b. Measure  $d_o$  and  $d_i$ .

c. Use the mirror/lens equation to calculate  $d_i$ .

d. Find the percent difference between your measured  $d_i$  and your calculated  $d_i$ .

e. Measure the magnification  $M$  and compare it to the calculated magnification.

20. Consider a concave mirror with unknown focal length that produces a virtual image six units behind the mirror.

a. Calculate the focal length of the mirror and draw an  $\times$  at the position of the focus.

b. *Carefully* trace three rays coming off the top of the object and show how they converge to form the image.

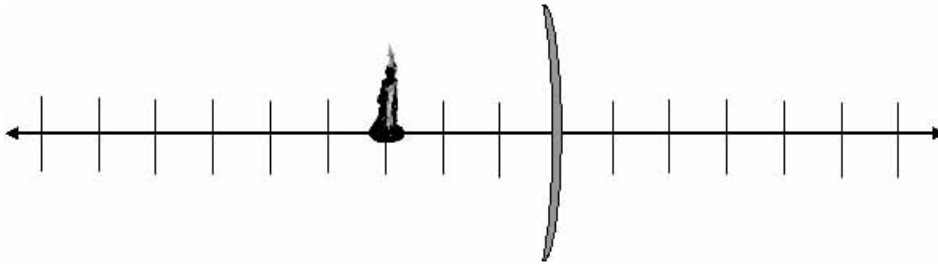

c. Does your image appear bigger or smaller than the object? Calculate the expected magnification and compare it to your sketch.

21. Consider a convex mirror with a focal length equal to two units.

a. *Carefully* trace three rays coming off the top of the object and form the image.

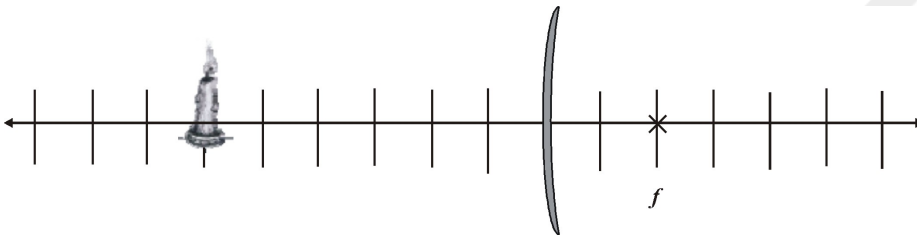

b. Measure  $d_o$  and  $d_i$ .

c. Use the mirror/lens equation to calculate  $d_i$ .

d. Find the percent difference between your measured  $d_i$  and your calculated  $d_i$ .

e. Measure the magnification  $M$  and compare it to the calculated magnification.

22. Consider a converging lens with a focal length equal to three units.

a. *Carefully* trace three rays coming off the top of the object and form the image.

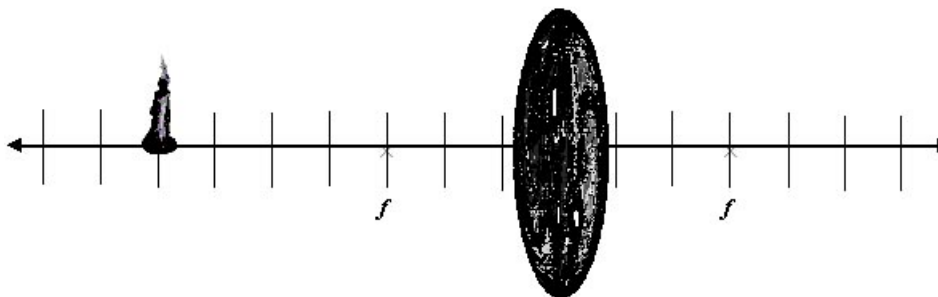

b. Measure  $d_o$  and  $d_i$ .

c. Use the mirror/lens equation to calculate  $d_i$ .

d. Find the percent difference between your measured  $d_i$  and your calculated  $d_i$ .

e. Measure the magnification  $M$  and compare it to the calculated magnification.

23. Consider a diverging lens with a focal length equal to four units.

a. *Carefully* trace three rays coming off the top of the object and show where they converge to form the image.

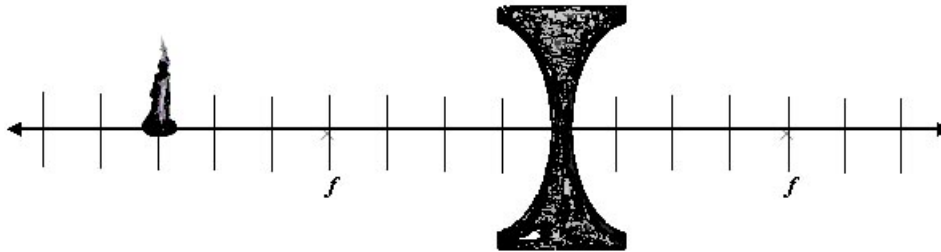

b. Measure  $d$  and  $d_i$ .

c. Use the mirror/lens equation to calculate  $d_i$ .

d. Find the percent difference between your measured  $d_i$  and your calculated  $d_i$ .

e. Measure the magnification  $M$  and compare it to the calculated magnification.

24. A piece of transparent goo falls on your paper. You notice that the letters on your page appear smaller than they really are. Is the goo acting as a converging lens or a diverging lens? Explain. Is the image you see real or virtual? Explain.

25. An object is placed 30 mm in front of a lens. An image of the object is located 90 mm behind the lens.

a. Is the lens converging or diverging? Explain your reasoning.

b. What is the focal length of the lens?

26. Little Red Riding Hood (*aka* R-Hood) gets to her grandmother's house only to find the Big Bad Wolf (*aka* BBW) in her place. R-Hood notices that BBW is wearing her grandmother's glasses and it makes the wolf's eyes look magnified (bigger).

a. Are these glasses for near-sighted or far-sighted people? For full credit, explain your answer thoroughly. You may need to consult some resources online.

b. Create a diagram of how these glasses correct a person's vision.

27. To the right is a diagram showing how to make a "ghost light bulb." The real light bulb is below the box and it forms an image of the exact same size right above it. The image looks very real until you try to touch it. What is the focal length of the concave mirror?

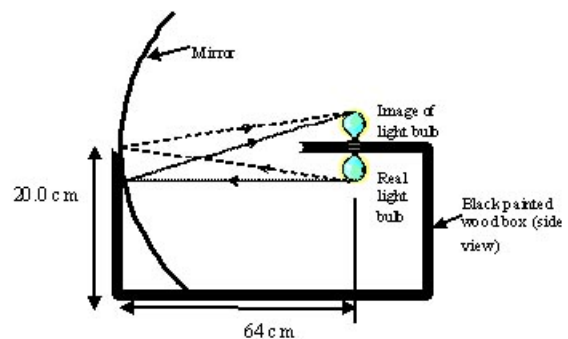

28. In your laboratory, light from a 650 nm laser shines on two thin slits. The slits are separated by 0.011 mm. A flat screen is located 1.5 m behind the slits.

a. Find the angle made by rays traveling to the third maximum off the optic axis.

b. How far from the center of the screen is the third maximum located?

c. How would your answers change if the experiment was conducted underwater?

29. Again, in your laboratory, 540 nm light falls on a pinhole 0.0038 mm in diameter. Diffraction maxima are observed on a screen 5.0 m away.

a. Calculate the distance from the central maximum to the first interference maximum.

b. Qualitatively explain how your answer to (a) would change if you ...

i. ...move the screen closer to the pinhole.

ii. ...increase the wavelength of light.

iii. ...reduce the diameter of the pinhole.

30. You are to design an experiment to determine the index of refraction of an unknown liquid. You have a small square container of the liquid, the sides of which are made of transparent thin plastic. In addition you have a screen, laser, ruler and protractors. Design the experiment. Give a detailed procedure; include a diagram of the experiment. Tell which equations you would use and give some sample calculations. Finally, tell in detail what level of accuracy you can expect and explain the causes of lab error in order of importance.

31. Students are doing an experiment with a Helium-neon laser, which emits 632.5 nm light. They use a diffraction grating with 8000 lines/cm. They place the laser 1 m from a screen and the diffraction grating, initially, 95 cm from the screen. They observe the first and then the second order diffraction peaks. Afterwards, they move the diffraction grating closer to the screen.

a. Fill in the table below with the *expected* data based on your understanding of physics. Hint: find the general solution through algebra *before* plugging in any numbers.

Distance of diffraction grating to screen (cm)	Distance from central maximum to first order peak (cm)
95	
75	
55	
35	
15	

b. Plot a graph of the first order distance as a function of the distance between the grating and the screen.

c. How would you need to manipulate this data in order to create a *linear* plot?

d. In a real experiment what could cause the data to deviate from the expected values? Explain.

e. What safety considerations are important for this experiment?

f. Explain how you could use a diffraction grating to calculate the unknown wavelength of another laser.

32. An abalone shell, when exposed to white light, produces an array of cyan, magenta and yellow. There is a thin film on the shell that both refracts and reflects the light. Explain clearly why these and only these colors are observed.

33. A crystal of silicon has atoms spaced 54.2 nm apart. It is analyzed as if it were a diffraction grating using an x-ray of wavelength 12 nm. Calculate the angular separation between the first and second order peaks from the central maximum.

34. Laser light shines on an oil film ( $n = 1.43$ ) sitting on water. At a point where the film is 96 nm thick, a 1<sup>st</sup> order dark fringe is observed. What is the wavelength of the laser?

35. You want to design an experiment in which you use the properties of thin film interference to investigate the variations in thickness of a film of water on glass.

- a. List all the necessary lab equipment you will need.
- b. Carefully explain the procedure of the experiment and draw a diagram.
- c. List the equations you will use and do a sample calculation using realistic numbers.
- d. Explain what would be the most significant errors in the experiment and what effect they would have on the data.

DRAFT

# 19. Fluids

AUTHOR: James H. Dann, Ph.D., James J. Dann SOURCE: The People's Physics Book LICENSE: CCSA



## The Big Idea

In studying fluids we apply the concepts of force, momentum, and energy, which we have learned previously, to new phenomena. Since fluids are made from a large number of individual molecules, we have to look at their behavior as a group. For this reason, we use the concept of conservation of *energy density* in place of conservation of energy. Energy density is energy divided by volume.

## Key Concepts

- The *pressure* of a fluid is a measure of the forces exerted by a large number of molecules when they collide and bounce off a boundary. The unit of pressure is the Pascal (Pa).
- Mass density represents the amount of mass in a given volume. We also speak of fluids as having gravitational potential energy *density*, kinetic energy *density*, and momentum *density*. These represent the amount of energy or momentum possessed by a given volume of fluid.
- Pressure and energy density have the same units:  $1 \text{ Pa} = 1 \text{ N/m}^2 = 1 \text{ J/m}^3$ . The pressure of a fluid can be thought of as an arbitrary level of energy density.
- For static fluids and fluids flowing in a steady state all locations in the connected fluid system must have the same total energy density. This means that the algebraic sum of pressure, kinetic energy density and gravitational energy density equals zero. Changes in fluid pressure must be equal to changes in energy density (kinetic and/or gravitational).
- Liquids obey a *continuity equation* which is based on the fact that liquids are very difficult to compress. This means that the total volume of a sample of fluid will always be the same. Imagine trying to compress a filled water balloon ...
- The *specific gravity* of an object is the ratio of the density of that object to the density of water. Objects with specific gravities greater than 1.0 (*i.e.*, greater than water) will sink in water; otherwise, they will float. The density of fresh water is  $1000 \text{ kg/m}^3$ .

## Key Equations

$P = F / A$	pressure is force per unit area.
$\rho = M / V$	mass density (“rho”) is mass over volume; the units of mass density are $\text{kg}/\text{m}^3$ .
$u_g = \rho gh$	gravitational potential energy density depends on the mass density of the fluid, the acceleration due to gravity, and the height of the fluid above an (arbitrary) ground level.
$k = \frac{1}{2}\rho v^2$	kinetic energy density is related to the mass density and speed of the fluid.
$P = \rho gh$	the pressure of a fluid depends on its depth.
$\Delta P + \Delta k + \Delta u_g = 0$	a conserved quantity – <i>Bernoulli’s Principle</i> .
$\Phi = A \cdot v$	the flux of a fluid through a certain cross-sectional area depends on its speed.
$F_{\text{buoy}} = \rho_{\text{water}} g V_{\text{displaced}}$	the buoyant force is equal to the weight of the displaced water.

### Key Applications

- In a fluid at rest, pressure increases in proportion to its depth – this is due to the weight of the water above you.
- *Archimedes’ Principle* states that the upward buoyant force on an object in the water is equal to the weight of the displaced volume of water. The reason for this upward force is that the bottom of the object is at lower depth, and therefore higher pressure, than the top. If an object has a higher density than the density of water, the weight of the displaced volume will be less than the object’s weight, and the object will sink. Otherwise, the object will float.
- *Pascal’s Principle* reminds us that, for a fluid of uniform pressure, the force exerted on a small area in contact with the fluid will be smaller than the force exerted on a large area. Thus, a small force applied to a small area in a fluid can create a large force on a larger area. This is the principle behind hydraulic machinery.
- *Bernoulli’s Principle* is a restatement of the conservation of energy, but for fluids. The sum of pressure, kinetic energy density, and gravitational potential energy density is conserved. In other words,  $\Delta P + \Delta k + \Delta u_g$  equals zero. One consequence of this is that a fluid moving at higher speed will exhibit a *lower* pressure, and vice versa. There are a number of common applications for this: when you turn on your shower, the moving water and air reduce the pressure in the shower stall, and the shower curtain is pulled inward; when a strong wind blows outside your house, the pressure decreases, and your shutters are blown open; due to the flaps on airplane wings, the speed of the air below the wing is lower than above the wing, which means the pressure below the wing is higher, and provides extra lift for the plane during landing. There are many more examples.
- Due to the conservation of flux,  $\Phi$ , which means that a smaller fluid-carrying pipe requires a faster moving fluid, and also due to Bernoulli’s Principle, which says that fast-moving fluids have low pressure, a useful rule emerges: pressure in a smaller pipe must be lower than pressure in a larger pipe.
- If the fluid is not in a steady state, energy can be lost in fluid flow. The loss of energy is related to *viscosity*, or deviation from smooth flow. Viscosity is related to *turbulence*, the tendency of fluids to become chaotic in their motion. In a high viscosity fluid, energy is lost from a fluid in a way that is quite analogous to energy loss due to current flow through a resistor. A pump can add energy to a fluid system also. The full Bernoulli Equation takes these two factors, viscosity and pumps, into account.



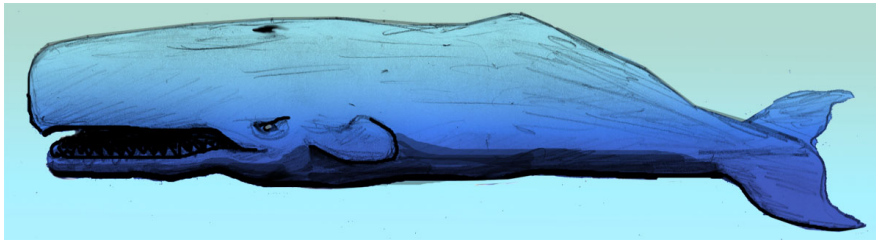

### Fluids Problem Set

1. A block of wood with a density of  $920 \text{ kg/m}^3$  is floating in a fluid of density  $1100 \text{ kg/m}^3$ . What fraction of the block is submerged, and what fraction is above the surface?

2. A rectangular barge 17 m long, 5 m wide, and 2.5 m in height is floating in a river. When the barge is empty, only 0.6 m is submerged. With its current load, however, the barge sinks so that 2.2 m is submerged. Calculate the mass of the load.

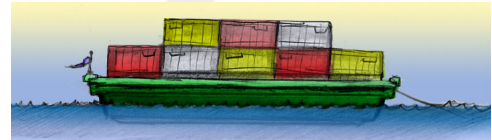

3. The density of ice is 90% that of water.

a. Why does this fact make icebergs so dangerous?

b. A form of the liquid naphthalene has a specific gravity of 1.58. What fraction of an ice cube would be submerged in a bath of naphthalene?

4. A cube of aluminum with a specific gravity of 2.70 and side length 4.00 cm is put into a beaker of methanol, which has a specific gravity of 0.791.

a. Draw a free body diagram for the cube.

b. Calculate the buoyant force acting on the cube.

c. Calculate the acceleration of the cube toward the bottom when it is released.

5. A cube of aluminum (specific gravity of 2.70) and side length 4.00 cm is put in a beaker of liquid naphthalene (specific gravity of 1.58). When the cube is released, what is its acceleration?

6. Your class is building boats out of aluminum foil. One group fashions a boat with a square 10 cm by 10cm bottom and sides 1 cm high. They begin to put 2.5 g coins in the boat, adding them until it sinks. Assume they put the coins in evenly so the boat doesn't tip. How many coins can they put in? (You may ignore the mass of the aluminum boat ... assume it is zero.)

7. You are riding a hot air balloon. The balloon is a sphere of radius 3.0 m and it is filled with hot air. The density of hot air depends on its temperature: assume that the density of the hot air is  $0.925 \text{ kg/m}^3$ , compared to the usual  $1.29 \text{ kg/m}^3$  for air at room temperature. The balloon and its payload (including you) have a combined mass of 100 kg.



- Draw a free body diagram for the cube.
- Is the balloon accelerating upward or downward?
- What is the magnitude of the acceleration?
- Why do hot air ballooners prefer to lift off in the morning?
- What would limit the maximum height attainable by a hot air balloon?

8. You are doing an experiment in which you are slowly lowering a tall, empty cup into a beaker of water. The cup is held by a string attached to a spring scale that measures tension. You collect data on tension as a function of depth. The mass of the cup is 520 g, and it is long enough that it never fills with water during the experiment. The following table of data is collected:

String tension (N)	Depth (cm)	Buoyant force (N)
5.2	0	
4.9	1	
4.2	3	
3.7	5	
2.9	8	
2.3	10	
1.7	12	
0.7	15	
0.3	16	
0	17	

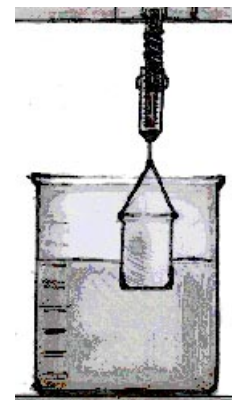

- Complete the chart by calculating the buoyant force acting on the cup at each depth.
- Make a graph of buoyant force vs. depth, find a best-fit line for the data points, and calculate its slope.
- What does this slope physically represent? (That is, what would a *greater* slope mean?)
- With this slope, and the value for the density of water, calculate the area of the circular cup's bottom and its radius.
- Design an experiment using this apparatus to measure the density of an unknown fluid.

9. A 1500 kg car is being lifted by a hydraulic jack attached to a flat plate. Underneath the plate is a pipe with radius 24 cm.

a. If there is no net force on the car, calculate the pressure in the pipe.

b. The other end of the pipe has a radius of 2.00cm. How much force must be exerted at this end?

c. To generate an upward acceleration for the car of  $1.0 \text{ m/s}^2$ , how much force must be applied to the small end of the pipe?

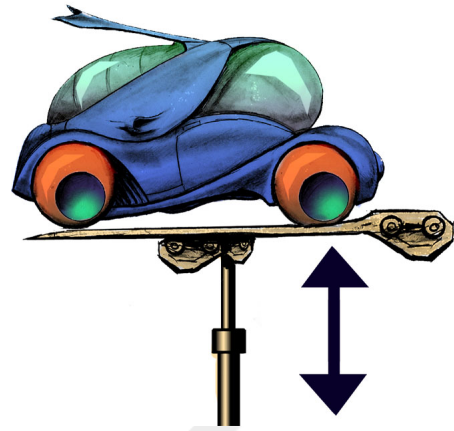

10. A SCUBA diver descends deep into the ocean. Calculate the water pressure at each of the following depths.

a. 15 m

b. 50 m

c. 100 m

11. What happens to the gravitational potential energy density of water when it is siphoned out of a lower main ditch on your farm and put into a higher row ditch? How is this consistent with Bernoulli's principle?

12. Water flows through a horizontal water pipe 10.0 cm in diameter into a smaller 3.00 cm pipe. What is the ratio in water pressure between the larger and the smaller water pipes?

13. A pump is required to pipe water from a well 7.0 m in depth to an open-topped water tank at ground level. The pipe at the top of the pump, where the water pours into the water tank, is 2.00 cm in diameter. The water flow in the pipe is 5.00 m/s.

a. What is the kinetic energy density of the water flow?

b. What pressure is required at the bottom of the well? (Assume no energy is lost – i.e., that the fluid is traveling smoothly.)

c. What power is being delivered to the water by the pump? (Hint: For the next part, refer to Chapter 12)

d. If the pump has an efficiency of 45%, what is the pump's electrical power consumption?

e. If the pump is operating on a 220 V power supply (typical for large pieces of equipment like this), how much electrical current does the pump draw?

f. At 13.5 cents per kilowatt-hour, how much does it cost to operate this pump for a month if it is running 5% of the time?

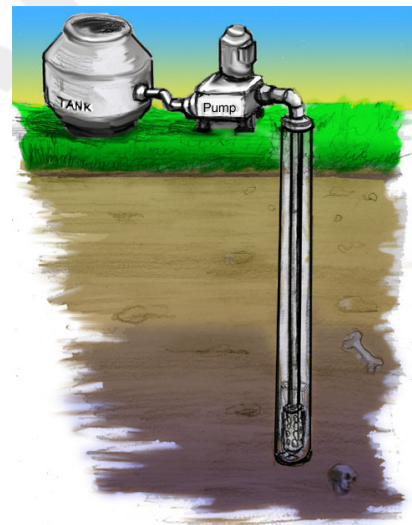

14. Ouch! You stepped on my foot! That is, you put a force of 550 N in an area of  $9 \text{ cm}^2$  on the tops of my feet!

a. What was the pressure on my feet?

b. What is the ratio of this pressure to atmospheric pressure?

15. A submarine is moving directly upwards in the water at constant speed. The weight of the submarine is 500,000 N. The submarine's motors are off.

a. Draw a sketch of the situation and a free body diagram for the submarine.

b. What is the magnitude of the buoyant force acting on the submarine?

16. You dive into a deep pool in the river from a high cliff. When you hit the water, your speed was 20m/s. About 0.75 seconds after hitting the water surface, you come to a stop before beginning to rise up towards the surface. Take your mass to be 60 kg.

a. What was your average acceleration during this time period?

b. What was the average net force acting on you during this time period?

c. What was the buoyant force acting on you during this time period?

17. A glass of water with weight 10 N is sitting on a scale, which reads 10 N. An antique coin with weight 1 N is placed in the water. At first, the coin accelerates as it falls with an acceleration of  $g/2$ . About half-way down the glass, the coin reaches terminal velocity and continues at constant speed. Eventually, the coin rests on the bottom of the glass.

What was the scale reading when...

a. ... the coin had not yet been released into the water?

b. ... the coin was first accelerating?

c. ... the coin reached terminal velocity?

d. ... the coin came to rest on the bottom?



18. You are planning a trip to the bottom of the Mariana Trench, located in the western Pacific Ocean. The trench has a maximum depth of 11,000 m, deeper than Mt. Everest is tall! You plan to use your bathysphere to descend to the bottom, and you want to make sure you design it to withstand the pressure. A bathysphere is a spherical capsule used for ocean descent – a cable is attached to the top, and this cable is attached to a winch on your boat on the surface.

a. Name and sketch your bathysphere.

b. What is the radius of your bathysphere in meters? (You choose – estimate from your picture.)

c. What is the volume of your bathysphere in  $m^3$ ?

d. What is the pressure acting on your bathysphere at a depth of 11,000 m? The density of sea water is  $1027 \text{ kg/m}^3$ .

e. If you had a circular porthole of radius 0.10 m (10 cm) on your bathysphere, what would the inward force on the porthole be?

f. If the density of your bathysphere is  $1400 \text{ kg/m}^3$ , what is the magnitude of the buoyant force acting on it when it is at the deepest point in the trench?

g. In order to stop at this depth, what must the tension in the cable be? (Draw an FBD!)

## 20. Thermodynamics and Heat Engines

AUTHOR: James H. Dann, Ph.D., James J. Dann SOURCE: The People's Physics Book LICENSE: CCSA

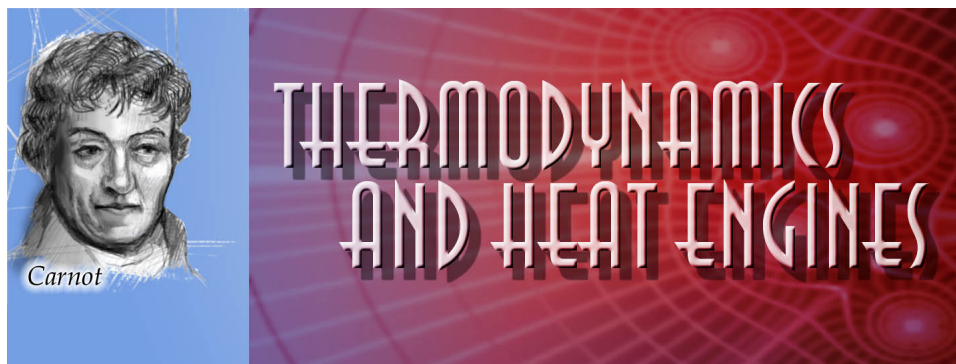

### The Big Ideas

Heat is a form of energy transfer. It can change the kinetic energy of a substance. For example, the average molecular kinetic energy of gas molecules is related to temperature. A heat engine provides heat to an engine in order to turn a portion of the input heat into mechanical work. A second portion of the input heat must be exhausted in order for the engine to have repetitive motion. Therefore, in a practical engine it is impossible for all the input heat to be converted to work.

Entropy is a measure of disorder, or the variety of ways in which a system can organize itself with the same total energy. The entropy of any isolated system always tends to disorder (i.e. entropy is always increasing). In the universe, the entropy of a subset (like evolution on Earth) can decrease (i.e. more order) but the total entropy of the universe is increasing (i.e. more disorder).

Thermodynamics is the study of heat engines. Any engine or power plant obeys the laws of thermodynamics. The *first law of thermodynamics* is a statement of conservation of energy. Total energy, including heat, is conserved in any process and in the complete cycle of a heat engine. The *second law of thermodynamics* as it applies to heat engines gives an absolute limit on the efficiency of any heat engine that goes through repetitious cycles.

### Key Concepts

- The temperature of a gas is a measure of the amount of average kinetic energy that the atoms in the gas possess.
- The pressure of a gas is the force the gas exerts on a certain area. For a gas in a container, the amount of pressure is directly related to the number and intensity of atomic collisions on a container wall.
- An *ideal* gas is a gas for which interactions between molecules are negligible, and for which the gas atoms or molecules themselves store no potential energy. For an “ideal” gas, the pressure, temperature, and volume are simply related by the ideal gas law.
- Atmospheric pressure (1 atm = 101,000 Pascals) is the pressure we feel at sea level due to the weight of the atmosphere above us. As we rise in elevation, there is less of an atmosphere to push down on us and thus less pressure.

- When gas pressure-forces are used to move an object then work is done on the object by the expanding gas. Work can be done on the gas in order to compress it.
- Adiabatic process: a process where no heat enters or leaves the heat engine.
- Isothermal: a process where the temperature does not change.
- Isobaric: a process where the pressure does not change.
- Isochoric: a process where the volume of the container does not change.
- If you plot pressure on the vertical axis and volume on the horizontal axis, the work done in any complete cycle is the area enclosed by the graph. For a partial process, work is the area underneath the curve, or  $P\Delta V$ .
- In a practical heat engine, the change in internal energy must be zero over a complete cycle. Therefore, over a complete cycle  $W = \Delta Q$ .
- The work done by a gas during a portion of a cycle =  $P\Delta V$ , note  $\Delta V$  can be positive or negative.
- The efficiency of any heat engine :  $\eta = W/Q_{in}$
- An ideal engine, i.e.: the most efficient even theoretically possible, is called a Carnot Engine. Its efficiency,  $\eta = 1 - T_{cold}/T_{hot}$  The temperatures are in Kelvins and are respectively the temperature of the exhaust environment and the temperature of the heat input. In a Carnot engine heat is inputted and exhausted in isothermal cycles.

### Key Equations

$\langle 1/2 mv^2 \rangle_{AVG} = 3/2 kT$	The average kinetic energy of atoms (each of mass $m$ and average speed $v$ ) in a gas is related to the temperature $T$ of the gas, measured in Kelvin. The Boltzmann constant $k$ is a constant of nature, equal to $1.38 \times 10^{-23}$ J/K.
$P = F / A$	The pressure on an object is equal to the force pushing on the object divided by the area over which the force is exerted. Unit for pressure are $N/m^2$ (called Pascals)
$PV = NkT$	An ideal gas is a gas where the atoms are treated as point-particles and assumed to never collide or interact with each other. If you have $N$ molecules of such a gas at temperature $T$ and volume $V$ , the pressure can be calculated from this formula. Note that $k=1.38 \times 10^{-23}$ J/K; this is the ideal gas law
$PV = nRT$	$V$ is the volume, $n$ is the number of moles; $R$ is the universal gas constant = $8.315$ J/K-n; this is the most useful form of the gas law for thermodynamics.
$Q_{in} = Q_{out} + W + \Delta U$	$U$ is the internal energy of the gas. (This is the first law of Thermodynamics and applies to all heat engines.)

### Thermodynamics and Heat Engines Problem Set

1. Consider a molecule in a closed box. If the molecule collides with the side of the box, how is the force exerted by the molecule on the box related to the momentum of the molecule? Explain conceptually, in words rather than with equations.

2. If the number of molecules is increased, how is the pressure on a particular area of the box affected? Explain conceptually, in words rather than with equations.
3. The temperature of the box is related to the average speed of the molecules. Use momentum principles to relate temperature to pressure. Explain conceptually, in words rather than with equations.
4. What would happen to the number of collisions if temperature and the number of molecules remained fixed, but the volume of the box increased? Explain conceptually, in words rather than with equations.
5. Use the reasoning in the previous four questions to qualitatively derive the ideal gas law.
6. Typical room temperature is about 300 K. As you know, the air in the room contains both  $O_2$  and  $N_2$  gases, with nitrogen the lower mass of the two. If the average kinetic energies of the oxygen and nitrogen gases are the same (since they are at the same temperature), which gas has a higher average speed?
7. Use the formula  $P = F / A$  to argue why it is easier to pop a balloon with a needle than with a finger (pretend you don't have long fingernails).
8. Take an empty plastic water bottle and suck all the air out of it with your mouth. The bottle crumples. Why, exactly, does it do this?
9. You will notice that if you buy a large drink in a plastic cup, there will often be a small hole in the top of the cup, in addition to the hole that your straw fits through. Why is this small hole necessary for drinking?
10. Suppose you were swimming in a lake of liquid water on a planet with a lower gravitational constant  $g$  than Earth. Would the pressure 10 meters under the surface be the same, higher, or lower, than for the equivalent depth under water on Earth? (You may assume that the density of the water is the same as for Earth.)
11. Why is it a good idea for Noreen to open her bag of chips before she drives to the top of a high mountain?
12. Explain, using basic physics conservation laws, why the following conditions would cause the ideal gas law to be violated:
  - a. There are strong intermolecular forces in the gas.
  - b. The collisions between molecules in the gas are inelastic.
  - c. The molecules are not spherical and can spin about their axes.
  - d. The molecules have non-zero volume.

To the right is a graph of the pressure and volume of a gas in a container that has an adjustable volume. The lid of the container can be raised or lowered, and various manipulations of the container change the properties of the gas within. The points  $a$ ,  $b$ , and  $c$  represent different stages of the gas as the container undergoes changes (for instance, the lid is raised or lowered, heat is added or taken away, etc.) The arrows represent the flow of time. Use the graph to answer the following questions.

13. Consider the change the gas undergoes as it transitions from point  $b$  to point  $c$ . What type of process is this?

- a. adiabatic
- b. isothermal
- c. isobaric
- d. isochoric

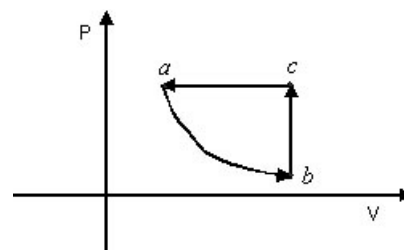

e. entropic

14. Consider the change the gas undergoes as it transitions from point *c* to point *a*. What type of process is this?

a. adiabatic

b. isothermal

c. isobaric

d. isochoric

e. none of the above

15. Consider the change the gas undergoes as it transitions from point *a* to point *b*. Which of the following *best* describes the type of process shown?

a. isothermal

b. isobaric

c. isochoric

16. How would an isothermal process be graphed on a P-V diagram?

17. Write a scenario for what you would do to the container to make the gas within undergo the cycle described above.

---

18. Calculate the average speed of N<sub>2</sub> molecules at room temperature (300 K). (You remember from your chemistry class how to calculate the mass (in kg) of an N<sub>2</sub> molecule, right?)

19. How high would the temperature of a sample of O<sub>2</sub> gas molecules have to be so that the average speed of the molecules would be 10% the speed of light?

20. How much pressure are you exerting on the floor when you stand on one foot? (You will need to estimate the area of your foot in square meters.)

21. Calculate the amount of force exerted on a 2 cm × 2 cm patch of your skin due to atmospheric pressure ( $P_0 = 101,000$  Pa). Why doesn't your skin burst under this force?

22. Use the ideal gas law to estimate the number of gas molecules that fit in a typical classroom.

23. Assuming that the pressure of the atmosphere decreases exponentially as you rise in elevation according to the formula  $P = P_0 e^{-\frac{h}{a}}$ , where  $P_0$  is the atmospheric pressure at sea level (101,000 Pa),  $h$  is the altitude in km and  $a$  is the *scale height* of the atmosphere ( $a \approx 8.4$  km).

a. Use this formula to determine the change in pressure as you go from San Francisco to Lake Tahoe, which is at an elevation approximately 2 km above sea level.

b. If you rise to half the scale height of Earth's atmosphere, by how much does the pressure decrease?

c. If the pressure is half as much as on sea level, what is your elevation?



24. At Noah's Ark University the following experiment was conducted by a professor of Intelligent Design (formerly Creation Science). A rock was dropped from the roof of the Creation Science lab and, with expensive equipment, was observed to gain 100 J of internal energy. Dr. Dumb explained to his students that the law of conservation of energy required that if he put 100 J of heat into the rock, the rock would then rise to the top of the building. When this did *not* occur, the professor declared the law of conservation of energy invalid.

- a. Was the law of conservation of energy violated in this experiment, as was suggested? Explain.
- b. If the law wasn't violated, then why didn't the rock rise?

25. An instructor has an ideal monatomic helium gas sample in a closed container with a volume of  $0.01\text{m}^3$ , a temperature of 412 K, and a pressure of 474 kPa.

- a. Approximately how many gas atoms are there in the container?
- b. Calculate the mass of the individual gas atoms.
- c. Calculate the speed of a typical gas atom in the container.
- d. The container is heated to 647 K. What is the new gas pressure?
- e. While keeping the sample at constant temperature, enough gas is allowed to escape to decrease the pressure by half. How many gas atoms are there now?
- f. Is this number half the number from part (a)? Why or why not?
- g. The closed container is now compressed isothermally so that the pressure rises to its original pressure. What is the new volume of the container?
- h. Sketch this process on a P-V diagram.
- i. Sketch cubes with volumes corresponding to the old and new volumes.

26. A famous and picturesque dam, 80 m high, releases 24,000 kg of water a second. The water turns a turbine that generates electricity.

- a. What is the dam's maximum power output? Assume that all the gravitational potential energy of the water is converted into electrical energy.
- b. If the turbine only operates at 30% efficiency, what is the power output?
- c. How many Joules of heat are exhausted into the atmosphere due to the plant's inefficiency?

27. A heat engine operates at a temperature of 650 K. The work output is used to drive a pile driver, which is a machine that picks things up and drops them. Heat is then exhausted into the atmosphere, which has a temperature of 300 K.

- a. What is the ideal efficiency of this engine?
- b. The engine drives a 1200 kg weight by lifting it 50m in 2.5 sec. What is the engine's power output?
- c. If the engine is operating at 50% of ideal efficiency, how much power is being consumed?
- d. How much power is exhausted?
- e. The fuel the engine uses is rated at  $2.7 \times 10^6$  J/kg. How many kg of fuel are used in one hour?

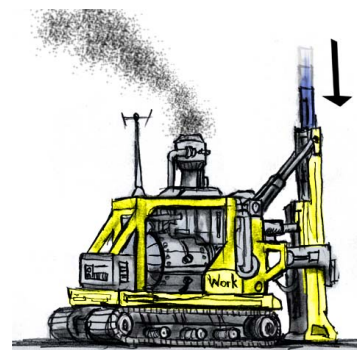

28. Calculate the ideal efficiencies of the following sci-fi heat engines:

a. A nuclear power plant on the moon. The ambient temperature on the moon is 15 K. Heat input from radioactive decay heats the working steam to a temperature of 975 K.

b. A heat exchanger in a secret underground lake. The exchanger operates between the bottom of a lake, where the temperature is 4 C, and the top, where the temperature is 13 C.

c. A refrigerator in your dorm room at Mars University. The interior temperature is 282 K; the back of the fridge heats up to 320 K.

29. How much external work can be done by a gas when it expands from 0.003 m<sup>3</sup> to 0.04 m<sup>3</sup> in volume under a constant pressure of 400 kPa? Can you give a practical example of such work?

30. In the above problem, recalculate the work done if the pressure linearly decreases from 400 kPa to 250kPa under the same expansion. Hint: use a PV diagram and find the area under the line.

31. One mole ( $N = 6.02 \times 10^{23}$ ) of an ideal gas is moved through the following states as part of a heat engine. The engine moves from state A to state B to state C, and then back again.

State	Volume (m <sup>3</sup> )	Pressure (atm)	Temperature (K)
A	0.01	0.60	
B	0.01	0.25	
C	0.02	0.25	

a. Draw a P-V diagram.

b. Determine the temperatures in states A, B, and C and then fill out the table.

c. Determine the type of process the system undergoes when transitioning from A to B and from B to C. (That is, decide for each if it is isobaric, isochoric, isothermal, or adiabatic.)

d. During which transitions, if any, is the gas doing work on the outside world? During which transitions, if any, is work being done on the gas?

e. What is the amount of net work being done by this gas?

32. A sample of gas is used to drive a piston and do work. Here's how it works:

The gas starts out at standard atmospheric pressure and temperature. The lid of the gas container is locked by a pin.

The gas pressure is increased isochorically through a spigot to twice that of atmospheric pressure.

The locking pin is removed and the gas is allowed to expand isobarically to twice its volume, lifting up a weight. The spigot continues to add gas to the cylinder during this process to keep the pressure constant.

Once the expansion has finished, the spigot is released, the high-pressure gas is allowed to escape, and the sample settles back to 1 atm.

Finally, the lid of the container is pushed back down. As the volume decreases, gas is allowed to escape through the spigot, maintaining a pressure of 1 atm. At the end, the pin is locked again and the process restarts.

a. Draw the above steps on a P-V diagram.

b. Calculate the highest and lowest temperatures of the gas.

33. A heat engine operates through 4 cycles according to the PV diagram sketched below. Starting at the top left vertex they are labeled clockwise as follows: a, b, c, and d.

- From a-b the work is 75 J and the change in internal energy is 100 J; find the net heat.
- From the a-c the change in internal energy is -20 J. Find the net heat from b-c.
- From c-d the work is -40 J. Find the net heat from c-d-a.
- Find the net work over the complete 4 cycles.
- The change in internal energy from b-c-d is -180 J. Find:
  - the net heat from c-d
  - the change in internal energy from d-a
  - the net heat from d-a

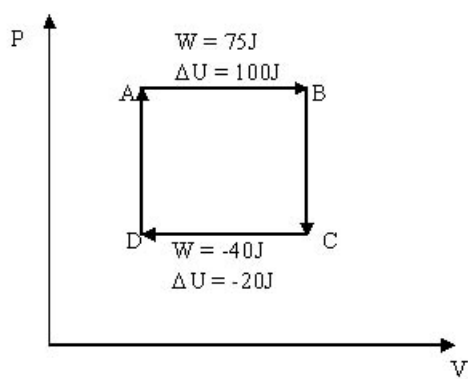

34. A 0.1 sample mole of an ideal gas is taken from state A by an isochoric process to state B then to state C by an isobaric process. It goes from state C to D by a process that is linear on a PV diagram, and then it goes back to state A by an isobaric process. The volumes and pressures of the states are given below:

state	Volume in $\text{m}^3 \times 10^{-3}$	Pressure in $\text{N/m}^2 \times 10^5$
A	1.04	2.50
B	1.04	4.00
C	1.25	4.00
D	1.50	2.50

- Find the temperature of the 4 states
- Draw a PV diagram of the process
- Find the work done in each of the four processes
- Find the net work of the engine through a complete cycle
- If 75 J of heat is exhausted in D-A and A-B and C-D are adiabatic, how much heat is inputted in B-C?
- What is the efficiency of the engine?

# 21. Radioactivity and Nuclear Physics

AUTHOR: James H. Dann, Ph.D., James J. Dann SOURCE: The People's Physics Book LICENSE: CCSA



## The Big Idea

The nuclei of atoms are affected by three forces: the strong nuclear force which causes protons and neutrons to bind together, the electric force, which is manifested by repulsion of the protons and tends to rip the nucleus apart, and the weak nuclear force, which causes neutrons to change into protons and vice versa.

The strong force predominates and can cause nuclei of complex atoms with many protons to be stable. The electric force of repulsion is responsible for fission, the breaking apart of nuclei, and it is responsible for atom bombs and nuclear power. A form of fission, where a helium nucleus is a product, is called *alpha radiation*. The actions of the weak force give rise to *beta radiation*. A change in nuclear energy can also give rise to *gamma radiation*, high energy electromagnetic waves. Particles that emit alpha radiation, beta radiation, and gamma radiation go through the process of *radioactive decay*, which causes the heating of the molten core of the earth, and has even played a role in the mutations in our evolutionary history. Fission and fusion, the latter occurring when light nuclei combine to form new elements, are accompanied by copious amounts of gamma radiation. These processes often produce radioactive nuclei; in nature these radioactive nuclei were forged in the explosive deaths of ancient stars.

## Key Equations

$N = N_0 \left(\frac{1}{2}\right)^{t/t_H}$	the number $N$ of nuclei surviving after an original $N_0$ nuclei decay for time $t$ with a half-life of $t_H$ .
$t = t_H \ln(N/N_0)/\ln(1/2)$	the amount of time $t$ it takes a set of nuclei to decay to a specified amount.
${}^A_Z X$	$X$ is the symbol for the element involved. For example, $U$ is the symbol for the element uranium. $Z$ is the atomic number. $A$ is the atomic mass number, the total number of nucleons (protons and neutrons). $A$ would be 235 for uranium.
$E = \Delta mc^2$	energy produced when some mass is lost during radioactive decay.

### Key Concepts

- Some of the matter on Earth is unstable and undergoing nuclear decay.
- Alpha decay is the emission of a helium nucleus, causing the product to have an atomic number 2 less than the original and an atomic mass number 4 less than the original.
- Beta minus decay is the emission of an electron, causing the product to have an atomic number 1 greater than the original
- Beta plus decay is the emission of a positron, causing the product to have an atomic number one less than the original.
- When an atomic nucleus decays, it does so by releasing one or more particles. The atom often (but not always) turns into a different element during the decay process. The amount of radiation given off by a certain sample of radioactive material depends on the amount of material, how quickly it decays, and the nature of the decay product. Big, rapidly decaying samples are most dangerous.
- The measure of how quickly a nucleus decays is given by the *half-life* of the nucleus. Half-life is the amount of time it will take for half of the radioactive material to decay.
- The type of atom is determined by the atomic number (i.e. the number of protons). The atomic mass of an atom is approximately the number of protons plus the number of neutrons. Typically, the atomic mass listed in a periodic table is an average, weighted by the natural abundances of different isotopes.
- The atomic mass number in a nuclear decay process is conserved. This means that you will have the same *total* atomic mass number on both sides of the equation. Charge is also conserved in a nuclear process.
- It is impossible to predict when an individual atom will decay; one can only predict the probability. However, it is possible to predict when a portion of a macroscopic sample will decay extremely accurately because the sample contains a vast number of atoms.
- The nuclear process is largely random in direction. Therefore, radiation strength decreases with distance by the inverse square of the distance (the  $1/r^2$  law, which also holds for gravity, electric fields, light intensity, sound intensity, and so on.)

### Key Applications

#### Alpha Decay



- *Alpha decay* is the process in which an isotope releases a helium nucleus (2 protons and 2 neutrons,



) and thus decays into an atom with two less protons.

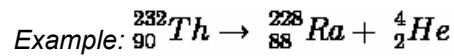

### Beta Decay



- *Beta decay* is the process in which one of the neutrons in an isotope decays, leaving a proton, electron and anti-neutrino. As a result, the nucleus decays into an atom that has the same number of nucleons, with one neutron replaced by a proton. (Beta positive decay is the reverse process, in which a proton decays into a neutron, anti-electron and neutrino.)

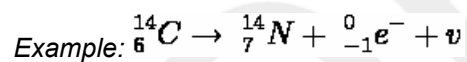

### Gamma Decay



- *Gamma decay* is the process in which an excited atomic nucleus kicks out a photon and releases some of its energy. The makeup of the nucleus doesn't change, it just loses energy. (It can be useful to think of this as energy of motion – think of a shuddering nucleus that only relaxes after emitting some light.)

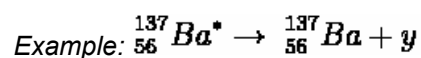

- *Fission* is the process in which an atomic nucleus breaks apart into two less massive nuclei. Energy is released in the process in many forms, heat, gamma rays and the kinetic energy of neutrons. If these neutrons collide with nuclei and induce more fission, then a runaway *chain reaction* can take place. Fission is responsible for nuclear energy and atom-bomb explosions: the fission of uranium acts as a heat source for the Earth's molten interior.

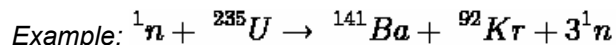

- *Fusion* is the process in which two atomic nuclei fuse together to make a single nucleus. Energy is released in the form of nuclear particles, neutrons, and gamma-rays.

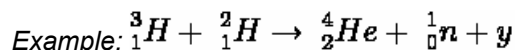

- *Radioactive carbon dating* is a technique that allows scientists to determine the era in which a sample of biological material died. A small portion of the carbon we ingest every day is actually the radioactive isotope  ${}^{14}\text{C}$  rather than the usual  ${}^{12}\text{C}$ . Since we ingest carbon every day until we die (we do this by eating plants; the plants do it through photosynthesis), the amount of  ${}^{14}\text{C}$  in us should begin to decrease from the moment we die. By analyzing the ratio of the number of  ${}^{14}\text{C}$  to  ${}^{12}\text{C}$  atoms in dead carbon-based life forms (including cloth made from plants!), we can determine how long ago the life form died.

### Radioactivity and Nuclear Physics Problem Set

1. After 6 seconds, the mass of a sample of radioactive material has reduced from 100 grams to 25 grams. Its half-life must be

- 1 s
- 2 s
- 3 s
- 4 s
- 6 s

2. Which of the following is true for the following reaction?

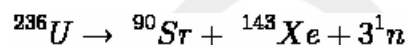

- This is a fission reaction.
- This is a fusion reaction.
- This is not a valid reaction, because the equations don't balance.

3. For any radioactive material, its half-life...

- ...first decreases and then increases.
- ...first increases and then decreases.
- ...increases with time.
- ...decreases with time.
- ...stays the same.

4. If the half-life of a substance is 5 seconds, it ceases to be radioactive (i.e. it ceases emitting particles), ...

- a. ... after 5 seconds.
- b. ... after 10 seconds
- c. ... after 20 seconds.
- d. ... after a very long time.

5. You detect a high number of alpha particles every second when standing a certain distance from a radioactive material. If you triple your distance from the source, the number of alpha particles you detect will decrease. By what factor will it decrease?

- a.  $\sqrt{3}$
- b. 3
- c. 9
- d. 27
- e. It will stay the same.

6. You have 5 grams of radioactive substance A and 5 grams of radioactive substance B. Both decay by emitting alpha-radiation, and you know that the higher the number of alpha-particles emitted in a given amount of time, the more dangerous the sample is. Substance A has a short half-life (around 4 days or so) and substance B has a longer half-life (around 10 months or so).

- a. Which substance is more dangerous right now? Explain.
- b. Which substance will be more dangerous in two years? Explain.

7. Write the nuclear equations  $A \rightarrow B + C$  for the following reactions.

- a. The alpha decay of  $^{219}\text{Ra}$ .
- b. The beta decay of  $^{158}\text{Eu}$ .
- c. The beta decay of  $^{53}\text{Ti}$ .
- d. The alpha decay of  $^{211}\text{Bi}$ .

8. A certain radioactive material has a half-life of 8 minutes. Suppose you have a large sample of this material, containing  $10^{25}$  atoms.

- a. How many atoms decay in the first 8 minutes?
- b. Does this strike you as a dangerous release of radiation? Explain.
- c. How many atoms decay in the second 8 minutes?
- d. What is the ratio of the number of atoms that decay in the first 8 minutes to the number of atoms that decay in the second 8 minutes?
- e. How long would you have to wait until the decay *rate* drops to 1% of its value in the first 8 minutes?



9. There are two equal amounts of radioactive material. One has a short half-life and the other has a very long half-life. If you measured the decay rates coming from each sample, which would you expect to have a higher decay *rate*? Why?
10. Hidden in your devious secret laboratory are 5.0 grams of radioactive substance A and 5.0 grams of radioactive substance B. Both emit alpha-radiation. Quick tests determine that substance A has a half-life of 4.2 days and substance B has a half-life of 310 days.
- How many grams of substance A and how many grams of substance B will you have after waiting 30 days?
  - Which sample (A or B) is more dangerous at this point (i.e., after the 30 days have passed)?
11. The half-life of a certain radioactive material is 4 years. After 24 years, how much of a 75 g sample of this material will remain?
12. The half life of  $^{53}\text{Ti}$  is 33.0 seconds. You begin with 1000 g of  $^{53}\text{Ti}$ . How much is left after 99.0 seconds?
13. You want to determine the half-life of a radioactive substance. At the moment you start your stopwatch, the radioactive substance has a mass of 10 g. After 2.0 minutes, the radioactive substance has 0.5 grams left. What is its half-life?
14. The half-life of  $^{239}\text{Pu}$  is 24,119 years. You have 31.25 micrograms left, and the sample you are studying started with 2000 micrograms. How long has this rock been decaying?
15. A certain fossilized plant is 23,000 years old. Anthropologist Hwi Kim determines that when the plant died, it contained 0.250 g of radioactive  $^{14}\text{C}$  ( $t_{1/2} = 5730$  years). How much should be left now?
16. A young girl unearths a guinea pig skeleton from the backyard. She runs a few tests and determines that 99.7946% of the original  $^{14}\text{C}$  is still present in the guinea pig's bones. The half-life of  $^{14}\text{C}$  is 5730 years. When did the guinea pig die?
17. You use the carbon dating technique to determine the age of an old skeleton you found in the woods. From the total mass of the skeleton and the knowledge of its molecular makeup you determine that the amount of  $^{14}\text{C}$  it began with was 0.021 grams. After some hard work, you measure the current amount of  $^{14}\text{C}$  in the skeleton to be 0.000054 grams. How old is this skeleton? Are you famous?
18. Micol had in her lab two samples of radioactive isotopes:  $^{151}\text{Pm}$  with a half-life of 1.183 days and  $^{134}\text{Ce}$  with a half-life of 3.15 days. She initially had 100 mg of the former and 50 mg of the latter.
- Do a graph of quantity remaining (vertical axis) vs. time for both isotopes on the same graph.
  - Using the graph* determine at what time the quantities remaining of both isotopes are exactly equal and what that quantity is.
  - Micol can detect no quantities less than 3.00 mg. Again, *using the graph*, determine how long she will wait until each of the original isotopes will become undetectable.
  - The Pm goes through  $\beta^-$  decay and the Ce decays by means of electron capture. What are the two immediate products of the radioactivity?
  - It turns out both of these products are themselves radioactive; the Pm product goes through  $\beta^-$  decay before it becomes stable and the Ce product goes through  $\beta^+$  decay before it reaches a stable isotope. When all is said and done, what will Micol have left in her lab?

## 22. Standard Model of Particle Physics

AUTHOR: James H. Dann, Ph.D., James J. Dann SOURCE: The People's Physics Book LICENSE: CCSA



### The Big Idea

All matter is composed of fundamental building blocks, called particles. These building blocks are much smaller than an atom, and so are sometimes referred to as *subatomic* particles. Particles interact with one another according to a set of rules. Sometimes particles interact by *exchanging* other particles. The set of particles and interactions we believe to exist is called the Standard Model. We know that this model is not complete, but it includes what we know today.

The fifth of the five conservation laws is called CPT symmetry. The law states that if you reverse the spatial coordinates of a particle, change it from matter to anti-matter, and reverse it in time the new object is now indistinguishable from the original.

### Matter

- Particles can be grouped into two camps: *fermions* and *bosons*. Typically matter is made up of fermions, while interactions (which lead to forces of nature such as gravity and electromagnetism) occur through the exchange of particles called bosons. (There are exceptions to this.) Electrons and protons are fermions, while photons (light particles) are bosons.
- Fermions (matter particles) can be broken into two groups: *leptons* and *quarks*. Each of these groups comes in three families.
- The first family of leptons consists of the *electron* and the *electron neutrino*. The second family consists of the *muon* and the *muon neutrino*. The third consists of the *tau* and the *tau neutrino*. Particles in each successive family are more massive than the family before it.
- The first family of quarks consists of the up and down quark. The second family consists of the charm and strange quarks. The third family consists of the top and bottom quarks.
- Up and down quarks combine (via the strong force) to form nucleons. Two ups and a down quark make a proton, while an up quark and two down quarks make a neutron. Different combinations of quarks are called *mesons*.

- Particles differ in their mass, their electric charge, their family (in the case of leptons), and their “spin.” Spin is a quantum mechanical concept that is best explained as a magnetic moment intrinsic to the particle and manifested as angular momentum.

### Interactions

- There are four fundamental forces in nature. From weakest to strongest, these are the gravitational force, the weak nuclear force, the electromagnetic force, and the strong nuclear force.
- Each fundamental force is transmitted by its own boson(s): for gravity, they are called gravitons; for the weak nuclear force, they are called  $W^-$ ,  $W^+$ , and  $Z^0$  bosons; for the electromagnetic force, they are called photons; and for the strong nuclear force, they are called gluons.
- In summary, the building blocks of matter and the interactions between matter consist of the following fundamental particles :

Fermions	Fermions
<i>Leptons</i>	<i>Quarks</i>
electron	up
electron neutrino	down
muon	strange
muon neutrino	charm
tau	top
tau neutrino	bottom

Bosons	Bosons
<i>Force Transmitted</i>	<i>Associated Boson</i>
gravity	graviton
electromagnetic	photon
weak	$W^-$ , $W^+$ , and $Z^0$
strong	gluons

### Rules

- For any interaction between particles, the five conservation laws (energy, momentum, angular momentum, charge, and CPT) must be followed. For instance, the total electric charge must always be the same before and after an interaction.
- Electron lepton number is conserved. This means that the total number of electrons *plus* electron neutrinos must be the same before and after an interaction. Similarly, muon lepton number and tau lepton number are also (separately) conserved. Note that matter gets lepton number of +1 and antimatter has lepton number of -1.
- Total quark number is conserved. Unlike leptons, however, this total includes *all* families. Again matter particles get quark number of +1 and antimatter -1.
- Photons can only interact with objects that have electric charge. This means that particles without charge (such as the electron neutrino) can never interact with photons.

- The strong nuclear force can only act on quarks. This means that gluons (the particle that carries the strong nuclear force) can only interact with quarks, or other gluons.
- The gravitational force can only act on objects with energy, and hence any object with mass.
- The weak nuclear force interacts with both quarks and leptons. However, the weak force is carried by any of three particles, called *intermediate vector bosons*:  $W^-$ ,  $W^+$ , and  $Z^0$ . Note that the  $W$  particles carry electric charge. This means you have to be more careful in making sure that any weak force interaction conserves electric charge.
- Any interaction which obeys all of these rules, and also obeys the usual rules of energy and momentum conservation, is allowed. Due to the randomness of particle interactions, any allowed interaction must eventually happen and thus has a non-zero probability of happening.

### Antimatter

- In addition to all of this, there is a further complication: each type of particle that exists (such as an electron or an up quark) has an antiparticle. Antiparticles are strange beasts: they have the same properties as their corresponding particles (mass, size, interactions) but their quantum numbers are exactly reversed electric charge, electron, muon, or tau lepton number, and quark number).
- There are two ways to denote something as an antiparticle. The most common is to draw a horizontal line above the thing. So, for instance, the antiparticle of the up quark is the anti-up quark:

$u$                        $\bar{u}$   
 up quark                      anti-up quark

- For charged leptons, you can merely switch the charge. So, for instance, an electron has negative charge and is written  $e^-$ , while its antiparticle, the anti-electron (also called a *positron*) is written  $e^+$ .

$e^-$                        $e^+$   
 electron                      anti-electron (*aka* positron)

- Particles and antiparticles annihilate each other, and convert their mass directly to energy in the form of gamma rays. Likewise, gamma rays can spontaneously revert to particle-antiparticle pairs. Matter and energy exchange places frequently in this process, with a conversion formula given by the famous equation  $E = mc^2$ .

### Resources

- Ask your teacher to provide you with a copy of the Standard Model of Particles and Interactions. If there aren't any available, please download and print out a copy of the Standard Model of Particles and Interactions, available at <http://particleadventure.org/>

### Standard Model of Particle Physics Problem Set

You will need a copy of the Standard Model to do this assignment. See above.

1. Which is more massive, the strange quark or the muon?
2. If you bound an up quark to an anti-strange quark using gluons, would the result be a proton, a neutron, an electron, or some type of meson?
3. Name three particles that do not interact with gluons.
4. Name three particles that do not interact with photons.

5. Which nucleon does not interact with photons? Why?
6. Does the electron neutrino interact with photons? Why or why not?
7. What quarks make up an anti-proton?
8. What rule would be violated if Dr. Shapiro attempted to turn an anti-electron (positron) into a proton?
9. Can any of the intermediate vector bosons ( $W^-$ ,  $W^+$ , and  $Z^0$ ) interact with light? If so, which?
10. What force (of the four) **must** be involved in the process of beta decay, in which a neutron disappears and turns into a proton, an electron, and an electron anti-neutrino?
11. In the world-view provided by the Standard Model, the universe of the very small contains which of the following? (Choose any and all that apply.)
  - a. Boson-exchange interactions between different types of quarks and leptons
  - b. Annihilation and creation of particle-antiparticle pairs
  - c. Electromagnetic interactions between charged objects
  - d. Electromagnetic interactions between  $Z^0$  bosons
  - e. Weak interactions involving quarks and leptons
  - f. Strong interactions between water molecules

Explain.

12. What is string theory? Why isn't string theory mentioned anywhere on the Standard Model? (If you are not already familiar with string theory, you may have to do some research online.)
13. Name three winners of the Nobel Prize who were directly investigating atomic and subatomic particles and interactions. Investigate online.

# 23. Feynman's Diagrams

AUTHOR: James H. Dann, Ph.D., James J. Dann SOURCE: The People's Physics Book LICENSE: CCSA

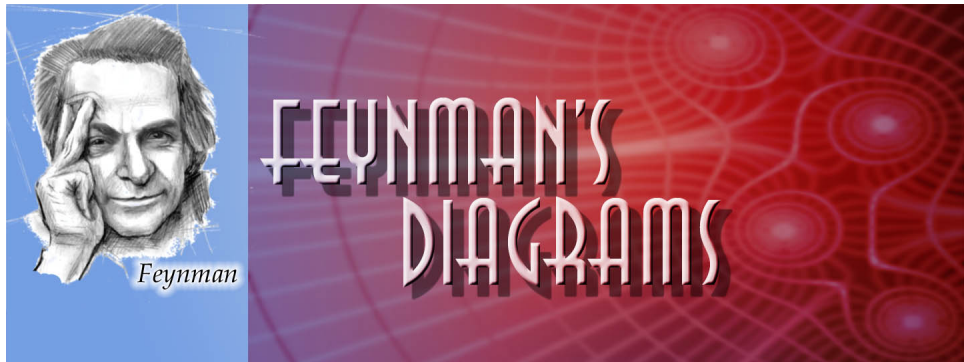

## The Big Idea

The interaction of subatomic particles through the four fundamental forces is the basic foundation of all the physics we have studied so far. There's a simple way to calculate the probability of collisions, annihilations, or decays of particles, invented by physicist Richard Feynman, called Feynman diagrams. Drawing Feynman diagrams is the first step in visualizing and predicting the subatomic world. All the Standard Model rules of the previous chapter are used here. You are now entering the weird world of particle physics.

## Key Concepts

- To make a Feynman diagram, you plot time on the horizontal axis and position on the vertical axis. This is called a space-time diagram.
- The fifth conservation law: CPT symmetry. States that if you charge conjugate (i.e. change matter to anti-matter), Parity reversal (i.e. mirror reflection) and then reverse the flow of time, a matter particle is exactly the same as the anti-matter particle (see below)

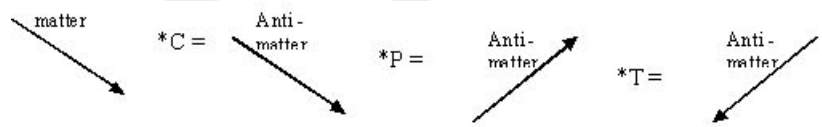
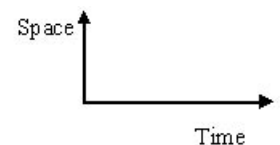

This is why anti-matter has its time arrow pointing backwards. And on collision diagrams, the matter is identical to the anti-matter after a CPT operation.

- If a particle is not moving, then we say that its space coordinate is fixed. Of course, if it's just sitting there, then it's moving through *time*. On the diagram below (left), the horizontal line shows the path of motion of a stationary particle. The diagram to the right shows the path of motion of a particle moving away from the origin at some speed.

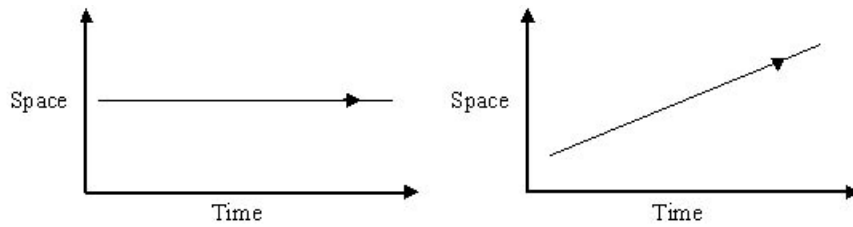

- Here are two particles colliding! Watch out!

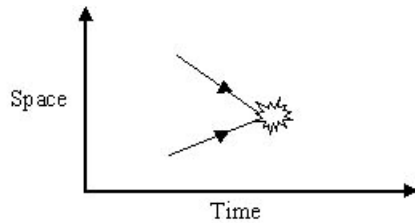

- We use the following symbols in Feynman diagrams:

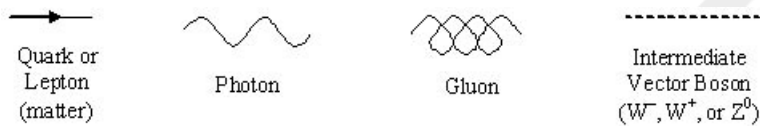

- *Annihilation Diagram:* When matter and antimatter particles collide, they annihilate, leaving behind pure energy for the example below in the form of electromagnetic radiation (photons!). A different set of matter and anti-matter is recreated soon thereafter. The Feynman diagram for that process looks like this:



Note that space and time axes have been left out; they are understood to be there. Also note that the arrow on the bottom is supposed to be backwards. We do that any time we have an antiparticle. Most people like to think of antiparticles as traveling backwards in time, and this is roughly explained by CPT symmetry.

It is very important that you remember that time is the horizontal axis! A lot of people see the drawing above and think of it as two particles coming together at an angle. These two particles are in a *head-on* collision, not hitting at an angle.

- *Scattering Diagram:* Here is the Feynman diagram for two electrons coming towards each other then repelling each other through the electromagnetic force (via *exchange* of a *virtual* photon). Note that the particles are always separated in space (vertical axis) so that they never touch. Hence they are scattering by exchanging virtual photons which cause them to repel. You can think of a virtual photon as existing for an instant of time. Therefore there is no movement in time (horizontal) axis.

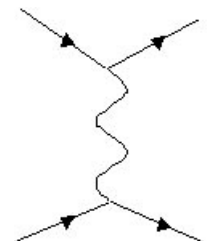

### Feynman Diagrams Problem Set

For the following Feynman diagrams, describe in words the process that is occurring. For instance: (a) what type of interaction: annihilation or scattering (b) what are the incoming articles? (c) which kind of boson mediates the interaction? (d) which fundamental force is involved in the interaction? (e) what are the outgoing particles?

Also, for each, decide if the interaction shown is *allowed*. An interaction is allowed if it does not violate any of the rules set out by the Standard Model of physics. If the interactions violate some rule, state which rule it violates. If they do not violate a rule, say that the interactions are allowed.

*Hint:* the best approach is to verify that the incoming and outgoing particles can interact with the boson (force particle) then to look at each vertex where more than one particle is coming together. Look immediately to the left of the vertex (before) and immediately to the right of the vertex (after). For instance, one rule states that the total electric charge before a vertex must equal the total electric charge after a vertex. Is that true? Check all the conserved quantities from the previous chapter in this way.

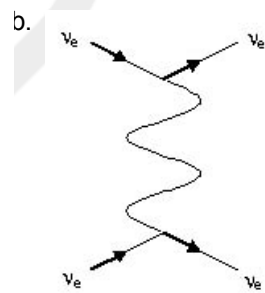
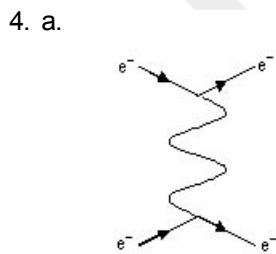
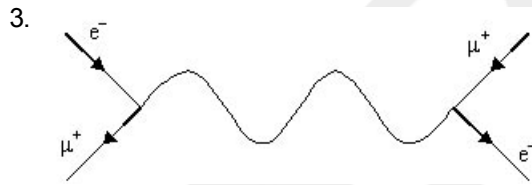
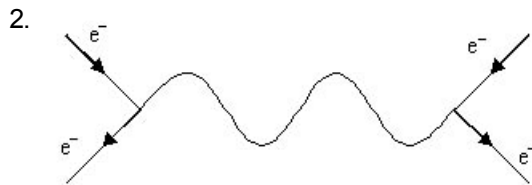
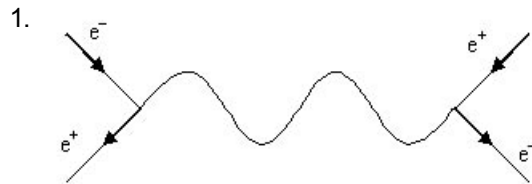



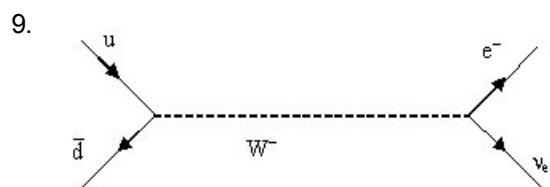
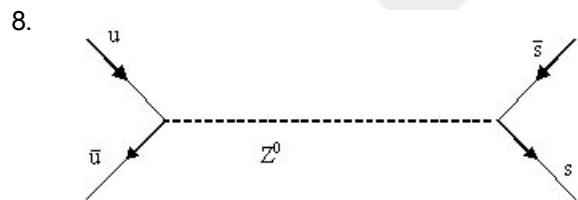
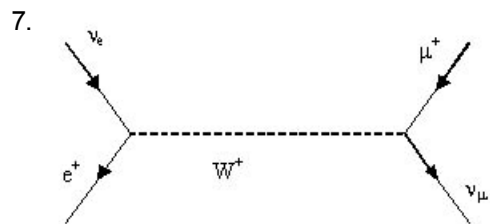
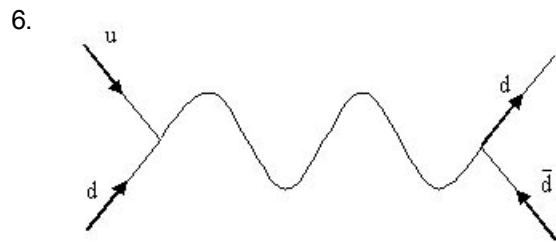
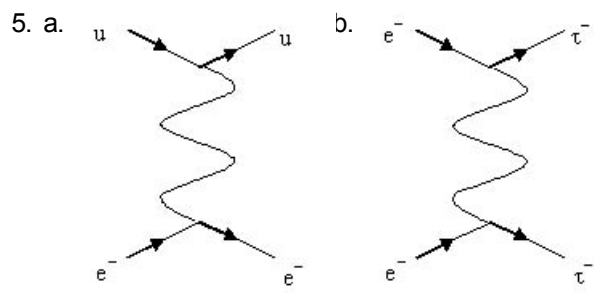

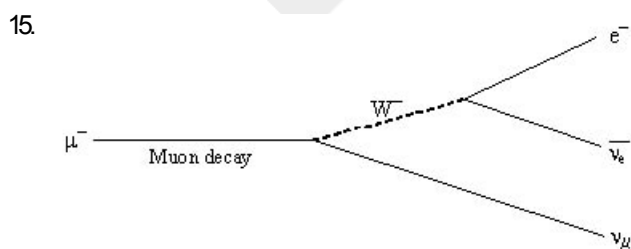
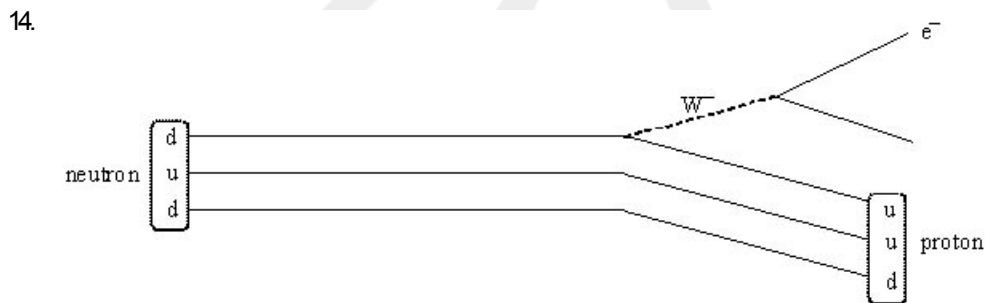
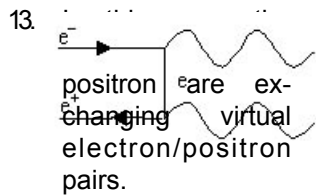
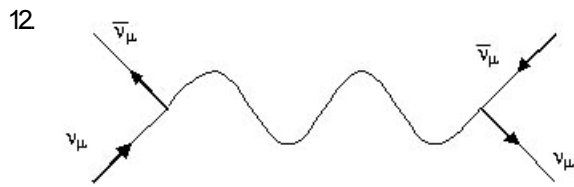
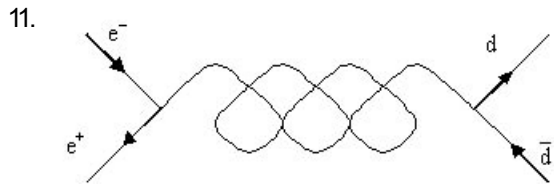
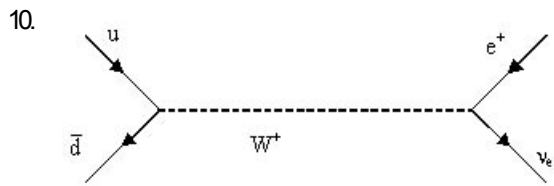

16. Draw all of the possible Feynman diagrams for the annihilation of an electron and positron, followed by motion of an exchange particle, followed by the creation of a new electron and positron. }

17. Draw the Feynman diagram for the collision of an up and anti-down quark followed by the production of a positron and electron neutrino. }

DRAFT

# 24. Quantum Mechanics

AUTHOR: James H. Dann, Ph.D., James J. Dann SOURCE: The People's Physics Book LICENSE: CCSA



## The Big Idea

Quantum Mechanics, discovered early in the 20<sup>th</sup> century, completely shook the way physicists think. Quantum Mechanics is the description of how the universe works on the very small scale. It turns out that we can predict not what will happen, but only the probability of what will happen. The uncertainty of quantum events is extremely important at the atomic or smaller level but not important at the macroscopic level. In fact the correspondence principle states that all results from quantum mechanics must agree with classical physics as the mass increases. The foundation of quantum mechanics was developed on the observation of *wave-particle duality*.

Electromagnetic Radiation is carried by particles, called photons, which interact with electrons. Depending on the experiment, photons can behave as particles or waves. The reverse is also true; electrons can also behave as particles or waves.

Because the electron has a wavelength, its position and momentum can never be precisely established. This is called the uncertainty principle. (What has been said above about the electron is true for protons or any other particle, but, experimentally, the effects become undetectable with increasing mass.)

## The Key Concepts

- The energy of a photon is the product of the frequency and Planck's Constant. This is the exact amount of energy an electron will have if it absorbs a photon.
- A photon, which has neither mass nor volume, carries energy and momentum; the quantity of either energy or momentum in a photon depends on its frequency. The photon travels at the speed of light.
- The five conservation laws hold true at the quantum level. Energy, momentum, angular momentum, charge and CPT are all conserved from the particle level to the astrophysics level.
- If an electron loses energy the photon emitted will have its frequency (and wavelength) determined by the difference in the electron's energy. This obeys the conservation of energy, one of the five conservation laws.
- An electron, which has mass (but probably no volume) has energy and momentum determined by its speed, which is always less than that of light. The electron has a wavelength determined by its momentum.

- If a photon strikes some *photoelectric* material its energy must first go into releasing the electron from the material (This is called the work function of the material.) The remaining energy, if any, goes into kinetic energy of the electron and the voltage of an electric circuit can be calculated from this. The current comes from the number of electrons/second and that corresponds exactly to the number of photons/second.
- Increasing the number of photons will not change the amount of energy an electron will have, but will increase the number of electrons emitted.
- The momentum of photons is equal to Planck's constant divided by the wavelength.
- The wavelength of electrons is equal to Planck's constant divided by the electron's momentum. If an electron is traveling at about  $.1c$  this wavelength is then not much smaller than the size of an atom.
- The size of the electron's wavelength determines the possible energy levels in an atom. These are negative energies since the electron is said to have zero potential energy when it is ionized. The lowest energy level (ground state) for hydrogen is  $-13.6$  eV. The second level is  $-3.4$  eV. Atoms with multiple electrons have multiple sets of energy levels. (And energy levels are different for partially ionized atoms.)
- When an electron absorbs a photon it moves to higher energy level, depending on the energy of the photon. If a  $13.6$  eV photon hits a hydrogen atom it ionizes that atom. If a  $10.2$  eV photon strikes hydrogen the electron is moved to the next level.
- Atomic spectra are unique to each element. They are seen when electrons drop from a higher energy level to a lower one. For example when an electron drops from  $-3.4$  eV to  $-13.6$  eV in the Hydrogen atom a  $10.2$  eV photon is emitted. The spectra can be in infra-red, visible light, ultra-violet and even X-rays. (The  $10.2$  eV photon is ultra-violet.)
- The wave nature of electrons makes it impossible to determine exactly both its momentum and position. The product of the two uncertainties is of the order of Planck's Constant. (Uncertainty in the electron's energy and time are likewise so related.)

### The Key Equations

$E = hf$	Relates energy of a photon to its frequency.
$p = h/\lambda$	Relates the momentum of a photon to its wavelength.
$\lambda = h/p$	The DeBroglie wavelength of an electron.
$(\Delta x) (\Delta p) \geq h/4\pi$	This is the Heisenberg Uncertainty Principle, (HUP) and relates the minimum measurable quantities in momentum and position of a particle.
$(\Delta E) (\Delta t) \geq h/4\pi$	Relates the uncertainty in measuring the energy of a particle and the time it takes to do the measurement.
$h = 6.626 \times 10^{-34}$ J-sec	Planck's constant.
$1 \text{ eV} = 1.602 \times 10^{-19}$ J	The most convenient unit of energy at the atomic scale is the electron volt, defined as the potential energy of the charge of an electron across a potential difference of 1 volt.
$1240\text{nm} \rightarrow 1\text{eV}$	A photon of energy of $1.00$ eV has a wavelength of $1240$ nm and vice versa. This is a convenient shortcut for determining the wavelengths of photons emitted

**Problems Set: Quantum Mechanics**

1. Calculate the energy and momentum of photons with the following frequency:
  - a. From an FM station at 101.9 MHz
  - b. Infrared radiation at  $0.90 \times 10^{14}$  Hz
  - c. From an AM station at 740 kHz
2. Find the energy and momentum of photons with a wavelength:
  - a. red light at 640 nm
  - b. ultraviolet light at 98.0 nm
  - c. gamma rays at .248 pm
3. Given the energy of the following particles find the wavelength of:
  - a. X-ray photons at 15.0 keV
  - b. Gamma ray photons from sodium 24 at 2.70 MeV
  - c. A 1.70 eV electron
4. The momentum of an electron is measured to an accuracy of  $5.10 \times 10^{-15}$  kg-m/s. What is the corresponding uncertainty in the position of the electron?
5. The four lowest energy levels in electron-volts in a hypothetical atom are respectively: -34 eV, -17 eV, -3.5 eV, -.27 eV.
  - a. Find the wavelength of the photon that can ionize this atom.
  - b. Is this visible light? Why?
  - c. If an electron is excited to the fourth level what are the wavelengths of all possible transitions? Which are visible?
6. Light with a wavelength of 620 nm strikes a photoelectric surface with a work function of 1.20 eV. What is the stopping potential for the electron?
7. For the same surface in the previous problem but different frequency light, a stopping potential of 1.40 V is observed. What is the wavelength of the light?
8. An electron is accelerated through 5000 V. It collides with a positron of the same energy. All energy goes to produce a gamma ray.
  - a. What is the wavelength of the gamma ray ignoring the rest mass of the electron and positron?
  - b. Now calculate the contribution to the wavelength of the gamma ray of the masses of the particles? Recalculate the wavelength.
  - c. Was it safe to ignore their masses? Why or why not?

9. An photon of 42.0 eV strikes an electron. What is the increase in speed of the electron assuming all the photon's momentum goes to the electron?

10. A 22.0 keV X-ray in the x-direction strikes an electron initially at rest. This time a 0.1 nm X-ray is observed moving in the x-direction after collision. What is the magnitude and direction of the velocity of the electron after collision?

11. The highly radioactive isotope Polonium 214 has a half-life of 163.7  $\mu\text{s}$  and emits a 799 keV gamma ray upon decay. The isotopic mass is 213.99 amu.

a. How much time would it take for 7/8 of this substance to decay?

b. Suppose you had 1.00 g of  $\text{Po}^{214}$  how much energy would the emitted gamma rays give off while 7/8 decayed?

c. What is the power generated in kilowatts?

d. What is the wavelength of the gamma ray?

12. Ultra-violet light of 110 nm strikes a photoelectric surface and requires a stopping potential of 8.00 volts. What is the work function of the surface?

13. Students doing an experiment to determine the value of Planck's constant shined light from a variety of lasers on a photoelectric surface with an unknown work function and measured the stopping voltage. Their data is summarized below:

Laser	Wavelength (nm)	Voltage (V)
Helium-Neon	632.5	.50
Krypton-Flouride	248	3.5
Argon	488	1.1
Europium	612	.60
Gallium arsenide	820	.05

a. Construct a graph of energy vs. frequency of emitted electrons.

b. Use the graph to determine the *experimental value of* Planck's constant

c. Use the graph to determine the work function of the surface

d. Use the graph to determine what wavelength of light would require a 6.0 V stopping potential.

e. Use the graph to determine the stopping potential required if 550 nm light were shined on the surface.

14. An element has the following six lowest energy (in eV) levels for its outermost electron: -24 eV, -7.5 eV, -2.1 eV, -1.5 eV, -.92 eV, -.69 eV.

a. Construct a diagram showing the energy levels for this situation.

b. Show all possible transitions; how many are there?

c. Calculate the wavelengths for transitions to the -7.5 eV level

d. Arrange these to predict which would be seen by infrared, visible and ultraviolet spectroscopes

15. A different element has black absorption lines at 128 nm, 325 nm, 541 nm and 677 nm when white light is shined upon it. Use this information to construct an energy level diagram.

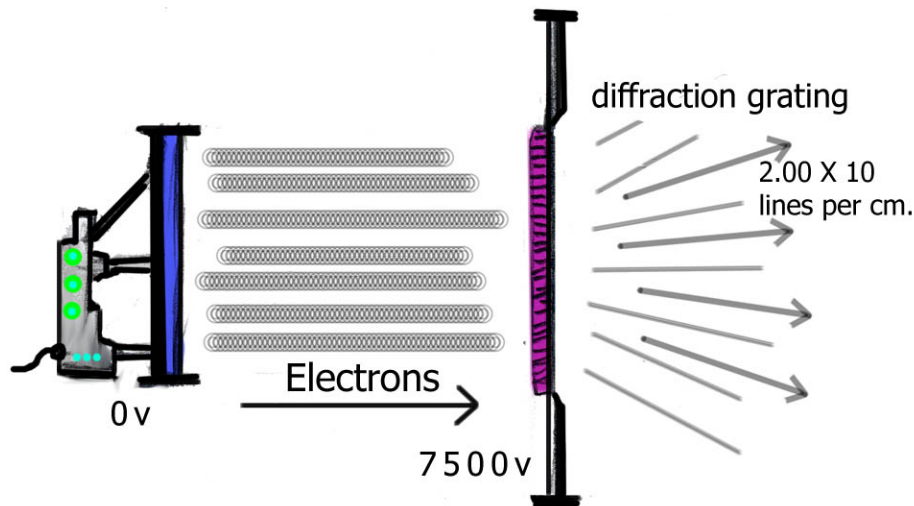

16. An electron is accelerated through 7500 V and is beamed through a diffraction grating, which has  $2.00 \times 10^7$  lines per cm.

- Calculate the speed of the electron
- Calculate the wavelength of the electron
- Calculate the angle in which the first order maximum makes with the diffraction grating
- If the screen is 2.00 m away from the diffraction grating what is the separation distance of the central maximum to the first order?

17. A light source of 429 nm is used to power a photovoltaic cell with a work function of 0.900 eV. The cell is struck by  $1.00 \times 10^{19}$  photons per second.

- What voltage is produced by the cell?
- What current is produced by the cell?
- What is the cell's internal resistance?

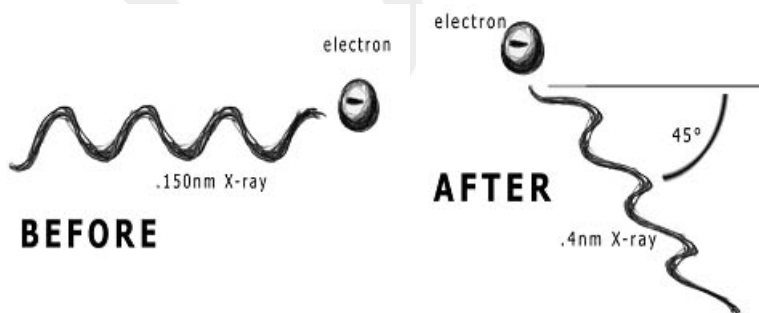

18. A .150 nm X-ray moving in the positive x-direction strikes an electron, which is at rest. After the collision an X-ray of 0.400 nm is observed to move 45 degrees from the positive x-axis.

- What is the initial momentum of the incident X-ray?
- What are the x and y components of the secondary X-ray?



c. What must be the x and y components of the electron after collision?

d. Give the magnitude and direction of the electrons' final velocity.

19. Curium 242 has an isotopic mass of 242.058831 amu and decays by alpha emission; the alpha particle has a mass of 4.002602 amu and has a kinetic energy of 6.1127 Mev.

a. What is the momentum of the alpha particle?

b. What is its wavelength?

c. Write a balanced nuclear equation for the reaction.

d. Calculate the isotopic mass of the product.

e. If the alpha particle is placed in a magnetic field of .002 T what is the radius of curvature? (The alpha particle has a double positive charge.)

f. If the alpha particle is moving in the x-direction and the field is in the z-direction find the direction of the magnetic force.

g. Calculate the magnitude and direction of the electric field necessary to make the alpha particle move in a straight line.

20. A student lab group has a laser of unknown wavelength, a laser of known wavelength, a photoelectric cell of unknown work function, a voltmeter and test leads, and access to a supply of resistors.

a. Design an experiment to measure the work function of the cell, and the wavelength of the unknown laser. Give a complete procedure and draw an appropriate circuit diagram. Give sample equations and graphs if necessary.

b. Under what circumstances would it be impossible to measure the wavelength of the unknown laser?

c. How could one using this apparatus also measure the intensity of the laser (number of photons emitted/second)?

21. The momentum of an electron is measured to an accuracy of  $\pm 5.1 \times 10^{-24}$  kg·m/s. What is the corresponding uncertainty in the position of the same electron at the same moment? Express your answer in Angstroms ( $1 \text{ \AA} = 10^{-10}$  m, about the size of a typical atom).

22. Thor, a baseball player, passes on a pitch clocked at a speed of  $45 \pm 2$  m/s. The umpire calls a strike, but Thor claims that the uncertainty in the position of the baseball was so high that Heisenberg's uncertainty principle dictates the ball *could* have been out of the strike zone. What is the uncertainty in position for this baseball? A typical baseball has a mass of 0.15 kg. Should the umpire rethink his decision?

23. Consider a box of empty space (vacuum) that contains nothing, and has total energy  $E = 0$ . Suddenly, in seeming violation of the law of conservation of energy, an electron and a positron (the anti-particle of the electron) burst into existence. Both the electron and positron have the same mass,  $9.11 \times 10^{-31}$  kg.

a. Use Einstein's formula ( $E = mc^2$ ) to determine how much energy must be used to create these two particles out of *nothing*.

b. You don't get to violate the law of conservation of energy forever – you can only do so as long as the violation is "hidden" within the HUP. Use the HUP to calculate how long (in seconds) the two particles can exist before they wink out of existence.

c. Now let's assume they are both traveling at a speed of 0.1 c. (Do a non-relativistic calculation.) How far can they travel in that time? How does this distance compare to the size of an atom?

d. What if, instead of an electron and a positron pair, you got a proton/anti-proton pair? The mass of a proton is about 2000× higher than the mass of an electron. Will your proton/anti-proton pair last a *longer* or *shorter* amount of time than the electron/positron pair? Why?

DRAFT

## 25. Physics with Calculus

AUTHOR: James H. Dann, Ph.D., James J. Dann SOURCE: The People's Physics Book LICENSE: CCSA

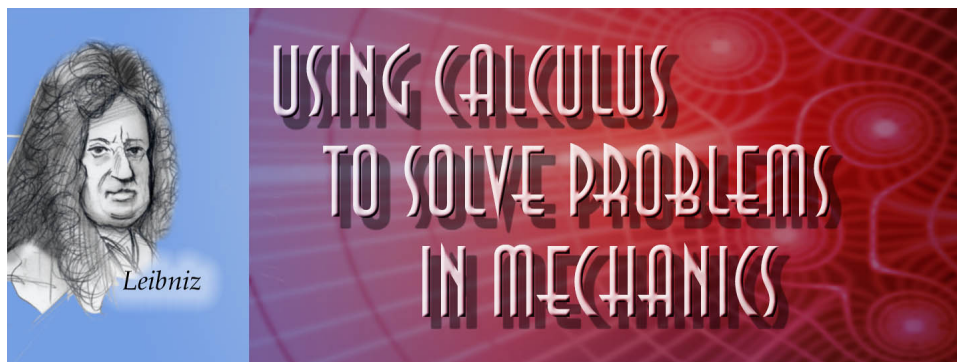

### The Big Idea

In most realistic situations forces and accelerations are not fixed quantities, but vary with time or displacement. In these situations, algebraic formulas cannot do better than approximate the situation, but the tools of calculus can give exact solutions. The *derivative* gives the instantaneous rate of change of displacement (velocity) and of the instantaneous rate of change of velocity (acceleration). The *integral* gives an infinite sum of the product of a force that varies with displacement times displacement (work), or similarly if the force varies with time (impulse).

### The Key Concepts:

- **Acceleration** is the derivative of velocity with respect to time. The slope of the tangent to the line of a graph of velocity vs. time is the acceleration.
- **Velocity** is the derivative of displacement with respect to time. The slope of the tangent to the line of a graph of displacement vs. time is the velocity.
- **Work** is the integral of the dot product of force as a function of displacement with respect to displacement. The area under the curve of a graph of force vs. displacement is the work. Note that the Force must be the component of force in the direction of displacement.
- **Impulse** is the time integral of force as a function of time. The area under the curve of a graph of force vs. time is the impulse.
- **Other Derivatives** include rotational velocity—angle with respect to time; angular acceleration—rotational velocity with respect to time.
- **Other Integrals** include moment of inertia, where mass varies with radius and rotational work, where torque varies with angle.
- **Harmonic Motion** can be written as a *differential equation*.

### The Key Equations:

$\mathbf{a} = d\mathbf{v}/dt = d^2 \mathbf{x}/dt^2$	Acceleration is the time derivative of velocity.
$\mathbf{v} = d\mathbf{x}/dt = \int \mathbf{a} dt$	Velocity is the time derivative of displacement.
$x = \int v dt$	The third of the "Big Three" equations for kinematics.
$W = \int \mathbf{F}(\mathbf{x}) \cdot d\mathbf{x}$	Work is the integral of force times displacement.
$P = dW/dt$	Power is the time derivative of work.
$\mathbf{J} = \int \mathbf{F}(t) dt = \Delta \mathbf{p}$	Impulse is the integral of force times time.
$\mathbf{r}_c = 1/M \int \mathbf{r}(m) dm$	The vector position of the center of mass can be found by integration. $M = \sum m_i$ where $\mathbf{r}(m)$ is the radius as a function of mass, for non-uniform bodies.
$\boldsymbol{\omega} = d\theta/dt$	Angular velocity is a derivative too.
$\alpha = d\boldsymbol{\omega}/dt$	Angular acceleration is a derivative.
$W = \int \boldsymbol{\tau}(\theta) d\theta$	Work in rotational motion integrates torque and angle.
$\boldsymbol{\tau} = d\mathbf{L}/dt$	Torque is the derivative of angular momentum.
$m d^2x/dt^2 = -k x(t)$	The differential equation of a spring in simple harmonic motion.
$d^2\theta/dt^2 = -g/l \theta(t)$	The differential equation of a pendulum, if $\theta$ is small such that $\sin \theta \approx \theta$ .

### Problem Set: Mechanics with Calculus

1. A particle moves in a straight line with its position,  $x$ , given by the following equation:  $x(t) = t^4 - 4t^3 + 2t^2 + 3t + 6$ .

- Find its position after 1 second
- Find its velocity after 2 seconds.
- Find its acceleration after 3 seconds.
- What is the rate of change of the acceleration at 1 second?
- Graph the rate of change of acceleration vs. time.

2. A coffee filter of mass,  $m$ , is dropped and finds that the air resistance,  $F_a$ , is given by the formula  $F_a = bv$ , where  $b$  is a constant and  $v$  is the velocity.

- Set up, but do not solve a differential equation for velocity as a function of time.
- Set up but do not solve a differential equation for distance as a function of time.
- Find the terminal velocity in terms of  $m$ ,  $b$ , and  $g$ .

d. If in a different situation the formula for air resistance were  $F_a = bv + cv^2$ , where  $c$  is another constant find the terminal velocity in terms of the above plus  $c$ .

3. Students are pulling a 2 kg friction block along a rough, but level, surface. In one case it is determined that the position of the block as a function of time is given by:  $x(t) = .3t^3 - .1t^2 + .2t$ .

- Find the speed of the block at  $t = 2$  sec.
- Find an expression for acceleration as a function of time.
- Find an expression for force as a function of time.

d. Find the initial kinetic energy of the block

e. Find the change in kinetic energy of the block from  $t = 0$  to  $t = 2$  sec.

f. Another lab group determines that the force as a function of distance is given by:  $F(x) = x^2 + 2x + 2$  and the block is pulled at an angle of 15 degrees to the horizontal. Find the change in kinetic energy from  $x=0$  to  $x=2$  meters.

g. For the above group find a differential equation for power.

4. An 800 kg sports car traveling at 20 m/s crashes into a SUV in a completely inelastic collision. The position of the wreck for the first 3 seconds is given by:  $x(t) = 8t + t^1 + 2t^2$ , where  $t = 0$  is the time of collision.

a. Give an expression for the velocity of the wreck as a function of time.

b. Find an expression for the acceleration of the wreck as a function of time.

c. Find the mass of the SUV.

d. Find an expression for the force as a function of time.

e. Find the impulse from  $t = 0$  to  $t = 3$  sec.

5. The vector position of a particle is given by  $\mathbf{r} = 3 \sin(2\pi t) \mathbf{i} + 2 \cos(2\pi t) \mathbf{j}$  where  $t$  is in seconds.

a. Plot the path of the particle in the x-y plane.

b. Find the velocity vector.

c. Find the acceleration vector and show that its direction is along  $\mathbf{r}$ ; that is, it is radial.

d. Find the times for which the speed is a maximum or minimum

6. Consider a bead of mass  $m$  that is free to move on a thin, circular wire of radius  $r$ . The bead is given an initial speed  $v_0$  and there is a coefficient of sliding friction  $\mu_k$ . The experiment is performed in a spacecraft drifting in space (i.e. no gravity to worry about)

a. Show that the speed of the bead at any subsequent time  $t$  is given by  $v(t) = v_0/[1+(\mu_k/r)v_0t]$ .

b. Plot  $v$  vs.  $t$  for  $v_0 = 10$  m/s,  $r = 5$  m, and  $\mu_k = 0.5$ . Label both axes with at least 5 numbers.

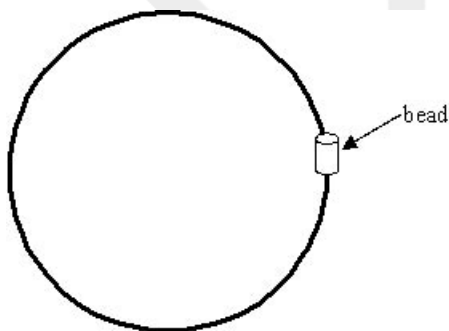

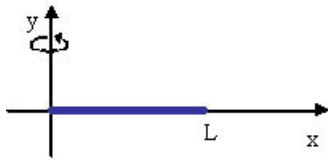

7. The above rod of length  $L$  is rotating about one end. It has a linear density given by

$$\lambda = \lambda_0 \left[ 1 + \frac{x}{L} \right] \text{ where } \lambda_0 = \frac{M}{L}$$

a. Find  $I_y$ .

b. Find the moment of inertia about an axis perpendicular to the rod and through its CM, letting  $x_0$  be the coordinate of its CM.

c. Where is the CM?

8. The position of a certain system with mass of 10 kg exhibits simple harmonic motion, where  $x(t) = 20 \cos\left(15.2t + \frac{\pi}{4}\right)$  and is in units of meters.

a. What is the total Energy of the system (let the Potential Energy be zero at the equilibrium position)?

b. At  $t = 0$ , what is the Potential Energy?

9. A device when compressed has a restoring force given by:  $F(x) = k_1x + k_2x^2$ . When  $x = 0$ ,  $F = 0$ .

a. Find an expression for the potential energy as a function of  $x$ .

b. When the device is released it goes through damped harmonic motion. The resisting friction force is given by  $-k_3v$ , where  $v$  is the velocity. Write but do not solve a differential equation describing the motion.

## 26. The Physics of Global Warming

AUTHOR: James H. Dann, Ph.D., James J. Dann SOURCE: The People's Physics Book LICENSE: CCSA



### The Big Idea

The observed global warming on Earth is a manifestation of the Second Law of Thermodynamics. The Earth operates like any heat engine. The input heat from solar radiation and the exhaust heat (terrestrial radiation) largely determine the operating temperature (global surface temperature). Over geological periods this heat exchange reaches equilibrium and the temperature is stable. If the input heat increases or the exhaust heat decreases the temperature rises and vice versa. Natural processes over geologic time have changed the input and affected both output heat and temperature. In the present era the quantity of exhaust heat is being rapidly restricted by the greenhouse effect and consequently the temperature must rise to reach a higher equilibrium temperature. How much higher depends entirely on human activity.

The input heat, solar energy received, is a function of solar activity and oscillations in characteristics of the Earth's orbit

The quantity of exhaust heat, terrestrial radiation, is largely a function of the presence of certain gases in the atmosphere that absorb outgoing infrared radiation. This is known as the greenhouse effect. The greenhouse effect is due to the differential absorption of certain wavelengths of solar as compared to terrestrial radiation.

The solar energy reaching the surface of the Earth is concentrated in short wavelengths, which can easily penetrate the greenhouse gases, such as Carbon Dioxide and Methane. The Earth, however, is cooler than the sun and it radiates its heat in the form of energy in the far infrared range. These longer wavelengths are partially absorbed by the greenhouse gases and some of the solar heat is returned to Earth. At a certain temperature these processes are in equilibrium and the surface temperature of the Earth is stable. However, if more greenhouse gases are put in the atmosphere the amount of trapped terrestrial radiation increases, leading to an increase in global temperature.

Currently the heating effect of extra greenhouse gases (since the start of the industrial revolution) is equal to about  $1.0 \text{ W/m}^2$ . Thus the recent period has recorded parallel increases in concentration of carbon dioxide and average global temperature. As more greenhouse gases are put into the atmosphere the temperature will increase further. There are certain effects of a warmer Earth (discussed below) which could accelerate the process, even if no more greenhouse gases are put into the atmosphere (an unlikely prospect for the foreseeable future).

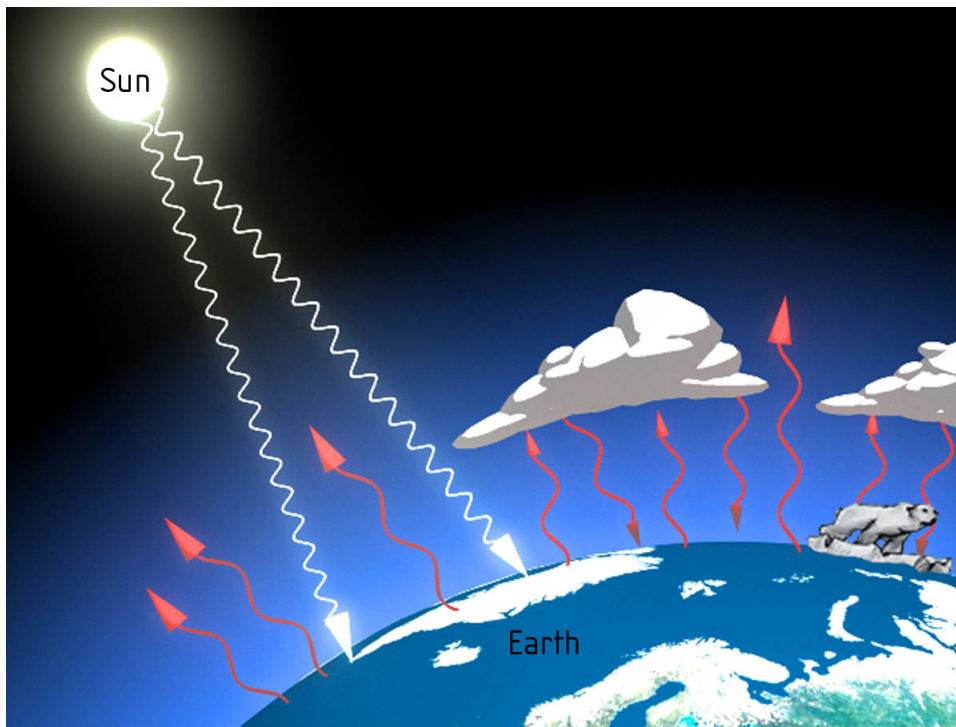

### The Key Concepts (Possible Effects That Can Accelerate Global Warming):

1. **Time Lag:** The excess energy warms the ocean very slowly, due to water's high heat capacity. Even in the unlikely event that no more greenhouse gases are added to the atmosphere the temperature increase already measured will be almost doubled.
2. **The Effect of Water Vapor:** Increasing temperatures will lead to more evaporation and more water vapor in the atmosphere. Water vapor is a greenhouse gas and its increased presence may cause further warming in a positive feedback loop. On the other hand if the water vapor results in more clouds more solar radiation will be reflected, a possible negative feedback.
3. **Albedo** is the amount of light reflected by a surface. Sea ice has an albedo of .85, meaning 85% of light is reflected back from its surface (and leaves the Earth) and 15% is absorbed and stays in the Earth; ice-free water has an albedo of .07. (93% of the solar energy is absorbed.) Thus the observed melting of sea ice could amplify the effect of global warming
4. The **melting of the Arctic Permafrost** also has an amplifying effect by releasing carbon dioxide and methane that is normally trapped in the tundra.
5. Warmer oceans are hostile to **algae and cytoplankton**, which are the most important absorbers of carbon dioxide. The loss of these two photosynthesizers would remove the most important natural CO<sub>2</sub> sink.
6. **Loss of Rainforests** would have a similar effect. Global warming is likely to lead to desertification of the habitats of rainforests. The rainforest is the second most important CO<sub>2</sub> sink.

### The Key Concepts (Physics Laws and Observations):

1. The relationship between temperature of a body and its radiation wavelength is given by **Wien's Law**: For any body that radiates energy, the wavelength of maximum energy radiated is inversely related to the temperature.
2. The effect of global warming on the solubility of Carbon Dioxide (CO<sub>2</sub>) and methane (CH<sub>4</sub>) is governed by two laws that partly contravene each other. **Henry's Law**: The solubility of a gas is directly proportional to the partial pressure of that gas. The constant of proportionality is Henry's Law Constant. This constant



of proportionality is temperature dependent and decreases as temperature increases. Therefore as carbon dioxide increases in the atmosphere the partial pressure of  $\text{CO}_2$  increases and more of it tends to dissolve in the oceans, but as the temperature increases the constant decreases and less of it tends to dissolve. The net effect at a given temperature will have to be calculated.

3. The **Solar Radiation** peaks at 610 nm; there is 61.2% of solar radiation is in the visible band (400-750 nm) with less than 9% in the uv band and about 30 % in the near infra red. Some 99% is radiated between 275 and 5000nm. This band largely is unabsorbed by any atmospheric gases. The most significant of the greenhouse gases are  $\text{H}_2\text{O}$  and  $\text{CO}_2$ . The plot above details the absorbance of various wavelengths of radiation by atmospheric gases in the shortwave region.

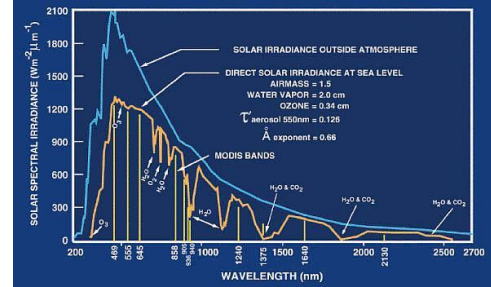

4. The **Earth's radiation** peaks at 11,000 nm, with an intensity of  $.04 \text{ W/cm}^2$ . Some 99% is radiated between 40,000 nm and 3000 nm in the longer infrared regions. This band is unabsorbed by nitrogen, oxygen and argon (99% of the Earth's current atmosphere), but partially absorbed by carbon dioxide, methane, water vapor, nitrous oxide and some minor gases. The gases that absorb this band of radiation are called *greenhouse gases*.

5. **Earth Orbital Changes:** There are three principal variations in orbit that are collectively known as the Milankovitch Cycles:

- a. precession of the rotational axis (period: 23,000 years)
- b. variation in tilt of rotational axis from  $21.5^\circ$  to  $24.5^\circ$  (period: 41,000 years)
- c. eccentricity of the elliptical orbit (period: 100,000 years)

Atmospheric concentrations of methane closely followed this cycle historically and on a larger time frame so have concentrations of  $\text{CO}_2$ .

6. **Departures from the historical cyclical trend** began 8000 years ago with the development of agriculture. This led to a temperature rise of  $0.8^\circ \text{C}$  above expected trends and concentrations of  $\text{CO}_2$  rising 30 ppm above expected trends with the concentration of methane 450 ppb above natural trends. In the last 100 years of industrialization these departures from normal have accelerated with temperature rising an additional  $0.8^\circ \text{C}$  and  $\text{CO}_2$  concentrations rising to 370 ppm, which is 90 ppm higher than the recorded  $\text{CO}_2$  concentrations at the warmest points in the interglacial periods. Methane concentrations are at 1750 ppb, 1000 ppb above historical highs. Over 70% of the extra greenhouse gases were added after 1950.  $\text{CO}_2$  is emitted whenever anything is burned, from wood to coal to gasoline. Methane is produced by animal husbandry, agriculture, and by incomplete combustion or leakage of natural gas. As more greenhouse gases are put into the atmosphere the temperature will increase further. The co-variation of  $\text{CO}_2$  concentrations and temperature has been demonstrated not only by recent observation, but by records of the last 700,000 years from Antarctic ice cores. There are many possible effects and feedback mechanisms that are currently being studied and modeled to better predict possible outcomes of this global trend. Many of these are identified above and in the following sections.

### The Key Applications:

1. Changing quantity of  $\text{CO}_2$  in oceans will lead to a **change in pH of the oceans**, changing its suitability as a habitat for some species of oceanic life.
2. **Human health problems** are associated with warmer temperatures including a projected 10-fold rise in mosquito populations and the diseases they bring as well as the already documented spread of malaria and dengue fever into areas in which these diseases were hitherto unknown.

3. **Loss of water supply:** A large part of human and other animal water supply is supplied from glaciers or melting snow-packs. This dependable supply will be disrupted or curtailed for many people. Especially vulnerable are Southeast Asia and India, which depend on the Himalayas, and much of South America, which depends on the Andes. In the US, California and the West stand to have a curtailed water supply in the summer months as a result of global warming.

#### 4. **Weather changes:**

a. Global Warming seems to cause the North Atlantic Oscillation to become stuck in the positive mode. The effect is to have warmer weather in Alaska, Siberia and western Canada, but colder weather in eastern Canada, Europe, and northeast US.

b. The same effect likely will lead to dry windy conditions in Europe and North America and dry conditions in much of Africa.

c. Models show global warming leading to droughts in most of the northern hemisphere, particularly in the grain belts of North America, Europe, and Asia.

d. At the same time, there is predicted to be increased rain overall, but coming in the form of severe storms and consequent flooding.

e. The conditions that lead to hurricanes and tornadoes are powered by solar energy. More solar energy in the ocean may lead to more severe hurricanes. There is some evidence to support that this has already occurred. The combination of warm Gulf waters and windy plains cause tornadoes. Both of these conditions will be increased by global warming.

5. Melting of the land glaciers will lead to **rising sea levels**. The Greenland ice sheet is moving into irreversible melting, which together with the loss of other land ice raise the ocean levels 8 meters in a century. Thermal expansion of water would add several tens of centimeters to this rising sea level.

6. **Ecosystems under stress:** When temperature changes occur over thousands of years, plants and animals adapt and evolve. When they happen over decades, adaptation is not always possible. The first flowering days of 385 plant species were on average 4.5 days earlier in 1991-2000 than normal. This can lead to lack of pollination and loss of fruiting.

A study in the Netherlands showed that weather changes caused oak buds to leaf sooner, causing winter moth caterpillars to peak in biomass earlier. The birds that depend on the caterpillars to feed their chicks did not delay their egg laying. This led to a mismatch of 13 days between food availability and food needs for these birds.

#### **The Key Equations:**

1.  $T\lambda_{\max} = A$ ; where  $A = 2.8978 \text{ m-K}$ ; Wien's Law

2.  $C = kP_{\text{partial}}$ ; Where  $k$  is temperature dependent and gas dependent;  $\text{CO}_2 @ 20^\circ = 3.91 \times 10^{-3} \text{ molal/atm}$ ,  $\text{CO}_2 @ 25^\circ = 3.12 \times 10^{-2} \text{ molal/atm}$ ;  $\text{CH}_4 @ 20^\circ = 1.52 \times 10^{-3} \text{ molal/atm}$ . The concentration is given in molals (Molal is moles of solute/kg of solvent) The partial pressure is given in atmospheres. Henry's Law

3. Energy imbalance of  $12 \text{ watt/m}^2\text{-year}$  leads to deglaciation that raises sea levels 1 meter.

4. Climate Sensitivity: Energy imbalance of  $1 \text{ W/m}^2 \rightarrow .75^\circ \text{ C} \pm .25^\circ \text{ C}$  change in average global temperature

5. Present Energy Imbalance = about  $1 \text{ W/m}^2 (\pm .5 \text{ W/m}^2)$

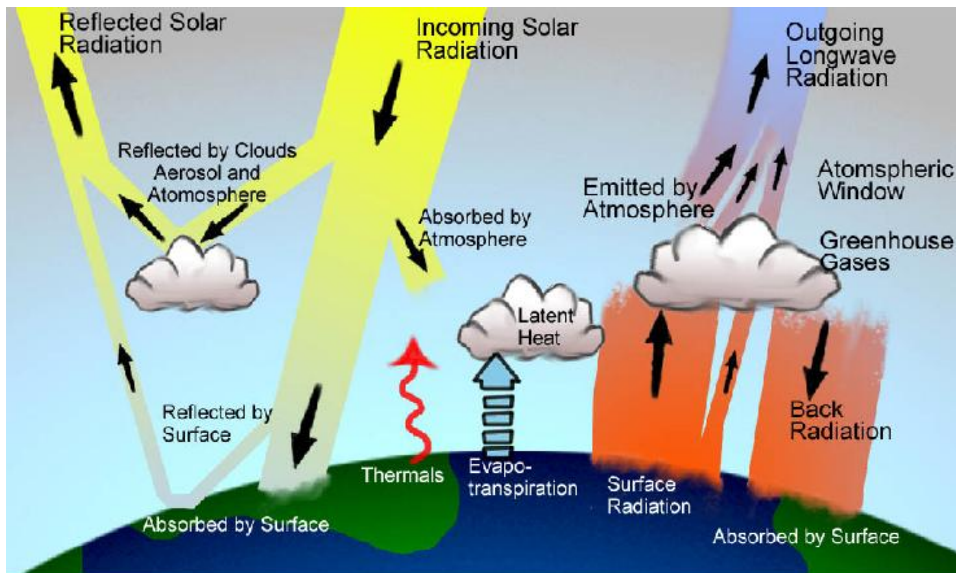

6. The picture above shows the normal energy balance of the Earth. Note that normally the  $342 \text{ W/m}^2$  incoming is balanced by  $235 \text{ W/m}^2$  outgoing +  $107 \text{ W/m}^2$  reflected radiation. At present, the atmospheric window allows only  $39 \text{ W/m}^2$  out resulting in a total of  $234 \text{ W/m}^2$  outgoing and an energy surplus of  $1 \text{ W/m}^2$  that results in temperature increases. (These figures are  $\pm .5 \text{ W/m}^2$ ).

7.  $1 \text{ kWh} = .68 \text{ kg CO}_2$  (EPA estimates)

8.  $10,000 \text{ kWh} = 1.4 \text{ cars off the road} = 2.9 \text{ acres of trees planted}$  (EPA estimates)

### Problem Set Chapter 26

1. One  $\text{W/m}^2$  energy imbalance may not seem much. (In the following calculations assume for the sake of significant digits that this is an exact number. It is in fact  $\pm 0.5 \text{ W/m}^2$ )

a. Calculate the total watts received by Earth. Surface area of a sphere is  $4\pi r^2$ .

b. Convert to energy in kWh.

c. How many joules of extra energy are received by Earth in a year?

d. To estimate the contrasting energy of an atomic bomb, assume  $100 \text{ kg}$  of  $\text{U}^{235}$ , isotopic mass of  $235.043924$ , is split into  $\text{Xe}^{142}$ , isotopic mass of  $141.929630$ ,  $\text{Sr}^{90}$ , isotopic mass of  $89.907738$  and 3 neutrons, each with mass of  $1.008665$ . All masses are given in amu's. First, find the mass difference between reactant and products. Then, converting to kilograms and using  $E = \Delta mc^2$ , find the energy in joules of an atomic bomb.

e. How many atomic bombs would have to be set off to equal the extra energy the Earth receives in one year from global warming?



2. It is estimated that a  $12 \text{ W/m}^2$  energy imbalance leads to sufficient melting of land ice to cause the sea levels to rise one meter.

- a. How many joules is that?
- b. What mass of ice is melted? The heat of fusion of water is  $3.33 \times 10^5 \text{ J/kg}$ .
- c. What volume of water is that? ( $\rho = 1000 \text{ kg/m}^3$ )
- d. From the above result, you should be able to estimate the surface area of the world's oceans and check the given estimate.

3. Given the uncertainty of  $\pm 0.5 \text{ W/m}^2$ , give the high and low estimates of global sea level rise in a century. Draw two new world maps using this data. Draw maps of your state, if it is a coastal state, 100 years from now given these estimates. (Perhaps your inland state will become a coastal state.)

4. Given the following table involving the growth in concentration of greenhouse gases:

year	$[\text{CO}_2]$ ppm	$[\text{CH}_4]$ ppb
1940	310	1100
1960	315	1250
1980	335	1550
2000	370	1750
2020 (IPCC* projection)	420	2150

\* *Intergovernmental Panel on Climate Change*

- a. Graph this data with time on the horizontal axis
- b. Determine the rate of increase in the concentrations of the two gases
  - i. 1940 - 2000
  - ii. 1960 - 2000
  - iii. 1980 - 2000
  - iv. the instantaneous rates of change in 2000
  - v. the instantaneous rates of change projected for 2020

5. Climate forcings can come from a variety of sources besides methane and carbon dioxide. Determine whether the following are positive feedbacks (contribute to global warming) or negative. You may have to

do some research on this.

- a. Black Carbon Soot
- b. Reflective Aerosols
- c. Chlorofluorocarbons
- d. Nitrous Oxide
- e. Ozone
- f. Cloud Droplet Changes



6. An overlooked area of additional global warming is the traditional cook stove. In one Honduran study, the soot smoke produced from one stove absorbed 65% of terrestrial radiation that then went into warming the atmosphere. There are 400 million such cook stoves worldwide, each of which emit 1.5g of soot per kilogram of wood burned. The average daily use of wood is 7.5 kg per stove. Calculate the mass of soot released through cook stoves per day, per year.

For Problems 7 - 10 use the following tables:

Electricity Emission Rates: (EPA)

State or region	CO <sub>2</sub> in kg/ Mwh	CH <sub>4</sub> in kg/Mwh	N <sub>2</sub> O in kg/Mwh
California	364.8	.00304	.00168
Michigan	740.1	.00662	.0133
New York City	494.3	.00367	.00404
Oregon	304.3	.00149	.00154

Global Warming Potential of Gases Compared to Carbon Dioxide (IPCC):

Greenhouse gas	Multiplier
Carbon dioxide CO <sub>2</sub>	1
Methane CH <sub>4</sub>	23
Nitrous Oxide N <sub>2</sub> O	296
A/C refrigerant HFC-143a	4300
Auto A/C refriger HFC-134a	1300

SF <sub>6</sub>	22,000
C <sub>2</sub> F <sub>6</sub>	11,900



7. A typical household air conditioner draws about 20 a from a 240 v line.
- If used for 8 hours how many kwh does it use?
  - In the course of a 120 day summer how many Mwh is that?
  - Calculate the mass of carbon dioxide one summer's use of ac contributes. (Pick a state or region from above.)
  - Calculate the mass of methane and N<sub>2</sub>O emitted.
  - Using the global warming multipliers for the latter two gases calculate the global warming potential in equivalent kg of CO<sub>2</sub> for all 3 gases.
8. If you “shut down” your computer, but the LED light is still on, it consumes about 4 w of power. Suppose you do that for every weekend (60 hours) every week of the year. Repeat the calculations in problem 7 to find out the global warming potential in kg of CO<sub>2</sub>.
9. In 2006 Natomas High School in California used 1692 Mwh of electricity. Repeating the calculations above, find the kg of carbon dioxide emitted.
10. A large car or SUV typically carries 1.0 kg of refrigerant for the a/c.
- If this were released into the atmosphere calculate the equivalent of carbon dioxide released.
  - Repeat this calculation for a residential air conditioner (capacity is 2.8 kg.), using HFC-143a.
  - Your school has a commercial chiller maybe (1000 ton) with a refrigerant capacity of 1225 kg. If it uses HFC-134a calculate the equivalent of CO<sub>2</sub> emitted, if the chiller is decommissioned.

#### Emissions of Carbon Dioxide for Different Fuels

Fuel	Kg of carbon dioxide emitted/gallon
Gasoline	8.78
California reformulated gasoline, 5.7% ethanol	8.55
Ethanol	6.10



Diesel #2	10.05
biodiesel	9.52
Jet fuel	9.47
propane	5.67
Natural gas/gasoline gallon equivalent	6.86

11. Compare the carbon “footprint” of the following:

- a. a hybrid car (45 mpg) that drives 21,000 mile per year in Calif.
- b. an SUV (17 mpg) that drives 21,000 miles per year also in Calif.
- c. a mid-size car (24mpg) that uses ethanol and drives 21,000 miles per year
- d. a commercial flatbed (11 mpg) that drives 21,000 miles per year and uses bio diesel



12. Research some typical mileages, type of fuel used, and miles covered in a year and determine the carbon footprint for:

- a. a tractor-trailer truck
- b. a commercial airliner
- c. a corporate jet
- d. a bus
- e. Amtrack

13. Looking at the above problems another way, suppose you want to travel from California to New York find your carbon footprint for the trip using:

- a. Amtrack
- b. a jet plane
- c. a bus
- d. an SUV
- e. a hybrid

Assume 90% full loads on the commercial transports and 2 passengers on the cars. You will have to go on-line to find the loads of the commercial transports.

14. China is putting two coal-fired electrical plants in operation each week. These plants do not typically use any scrubbing or pollution controls. Research the typical Mwh output, and, using either the table for problem 7 (Michigan depends more on coal than the other states listed.) or a more direct source for CO<sub>2</sub> emissions for a coal plant, find the gain in greenhouse gas emissions each year from this source alone. Compare to the results in problem 4 and determine if the IPCC is underestimating the problem.

DRAFT



# 27. Answers to Selected Problems

AUTHOR: James H. Dann, Ph.D., James J. Dann SOURCE: The People's Physics Book LICENSE: CCSA

## Appendix A: Answers to Selected Problems (3e)

### Ch 1: Units and Problem Solving

- 1a. A person of height 5 ft. 11 in. is 1.80 m tall
- 1b. The same person is 180 cm
- 2a. 3 seconds = 1/1200 hours
- 2b.  $3 \times 10^3$  ms
3. 87.5 mi/hr
- 4c. if the person weighs 150 lb. this is equivalent to 668 N
5. Pascals (Pa), which equals  $\text{N/m}^2$
6. 168 lb., 76.2 kg
7. 5 mi/hr/s
8. 15.13 m
9. 11.85 m
10. 89,300 mm
- 11f.  $2025 \text{ mm}^2$
- 12b.  $196 \text{ cm}^2$
- 13c.  $250 \text{ cm}^3$
14. 8:1, each side goes up by 2 cm, so it will change by  $2^3$
15.  $3.5 \times 10^{51}:1$
16. 72,000 km/h
17. 0.75 kg/s
18.  $8 \times 2^N \text{ cm}^3/\text{sec}$ ;  $N$  is for each second starting with 0 seconds for  $8 \text{ cm}^3$
19. About 12 million
20. About  $1\frac{1}{2}$  trillion ( $1.5 \times 10^{12}$ )
21.  $[a] = \text{N/kg} = \text{m/s}^2$

### Ch 2: Energy Conservation

1. d
2. (discuss in class)
- 3a.  $5.0 \times 10^5 \text{ J}$
- 3b.  $3.7 \times 10^5 \text{ J}$
- 3c. Chemical bonds in the food.
- 3d. 99 m/s
- 4a.  $5.0 \times 10^5 \text{ J}$
- 4b. 108 m/s
- 5a. 450,000 J
- 5b. 22,500 J
- 5c. 5,625 J
- 5d. 21.2 m/s
- 5e. 9.18 m
- 7b.  $\text{KE} = 504,600 \text{ J}$ ;  $U_g = 1,058,400 \text{ J}$ ;  $E_{\text{total}} = 1,563,000 \text{ J}$
- 8a. 34 m/s at B; 28 m/s at D, 40 m/s at E, 49 m/s at C and F; 0 m/s at H
- 8b. 96 m
- 9a. 1.7 J
- 9b. 1.3 m/s
- 9c. 0.4 J, 0.63 m/s
- 10a.  $1.2 \text{ m/s}^2$
- 10b. 130 J
- 11a. 6750 J
- 11b.  $2.25 \times 10^5 \text{ J}$
- 11c.  $1.5 \times 10^5 \text{ J/gallon of gas}$

12. 0.76 m

### Ch 3: One-Dimensional Motion

5a. Zyan

5c. Ashaan

5f. Ashaan

9d. 20 meters

9f. 2.67 m/s

9h. Between  $t = 15$  s and  $t = 20$  sec because your position goes from  $x = 30$  m to  $x = 20$  m.

10a.  $7.7 \text{ m/s}^2$

10c. 34 m/s

11b. 4.9 m/s

11d. -4.9 m/s

12c. at 2 seconds

13a. 250 m

13c. 14 s for round trip

15.  $-31 \text{ m/s}^2$

16b. 3.6 seconds

16d. 45 m

17b. 30 m

18.  $2 \text{ m/s}^2$

19b.  $10 \text{ m/s}^2$

19d. 60 m

20b. 0.5 m/s

5b. Ashaan is accelerating because the distance he travels every 0.1 seconds is increasing, so the speed must be increasing

5d. Zyan

8. 6 minutes

9e. 40 meters

9g. 6 m/s

9i. You made some sort of turn

10b. 47 m, 150 feet

11a. 1.22 m

11c. 2.46 m/s

12b. 1 second

12d. 4 m

13b. 13 m/s, -13 m/s

14. Let's say we can jump 20 feet (6.1 m) in the air. ☹ Then, on the moon, we can jump 36.5 m straight up.

16a. 23 m/s

16c. 28 m

17a. 25 m/s

17c.  $2.5 \text{ m/s}^2$

19a.  $v_0 = 0$

19c.  $-10 \text{ m/s}^2$

20a.  $0.3 \text{ m/s}^2$

### Ch 4: Two-Dimensional and Projectile Motion

7a. 13 m

7c.  $v_y = 26 \text{ m/s}$ ;  $v_x = 45 \text{ m/s}$

9. 32 m

10b. 0.8 m/s

12.  $t = 0.60$  s, 1.8 m below target

14a. 3.5 s.

15. 40 m; 8.5 m

17. 50 m;  $v_{oy} = 30 \text{ m/s}$ ;  $50^\circ$ ; on the way up

19.  $19^\circ$

21. 2.3 m/s

23. 1.4 seconds

24b. 14 m/s @ 23 degrees from horizontal

7b. 41 degrees

7d. 56 degrees, 14 m/s

10a. 0.5 s

11. 104 m

13. 28 m.

14b. 35 m; 15 m

16. 1.3 seconds, 7.1 meters

18. 4.4 s

20. 0.5 s

22. 6 m

24a. yes

25. 22 m/s @ 62 degrees

## Ch 5: Newton's Laws

4. Zero; weight of the hammer minus the air resistance.
6. 1 force
8. The towel's inertia resists the acceleration
- 9b. You go farther
- 11a. 98 N
13. 32 N
17.  $F_x = 14 \text{ N}$ ,  $F_y = 20 \text{ N}$
19.  $3 \text{ m/s}^2$  east
21. 0.51
23. The rope will not break because his weight of 784 N is distributed between the two ropes.
25. Mass is 51 kg and weight is 82 N
- 26b. 686 N
- 27a. 390 N
28. 0.33
30.  $g \sin \theta$
- 31c. 4.9 N
- 31e. Eraser would slip down the wall
- 32b. 5600 N
- 32d. Friction between the tires and the ground
- 33b. 210 N
- 33d.  $2.8 \text{ m/s}^2$
- 33f. no
- 33h. 57 N
- 33j. 0.33
- 35a. zero
- 36b.  $f_1 = \mu_k m_1 g \cos \theta$ ;  $f_2 = \mu_k m_2 g \cos \theta$
- 36d.  $T_A = (m_1 + m_2)(a + \mu \cos \theta)$  and  $T_B = m_2 a + \mu m_2 \cos \theta$
- 37a. Yes, because it is static and you know the angle and  $m_1$
- 38a. 3 seconds
- 42a. 1.5 N; 2.1 N; 0.71
5. 2 forces
7. No
- 9a. Same distance
- 9c. Same amount of force
- 11b. 98 N
14.  $5.7 \text{ m/s}^2$
18. Left picture:  $F = 23 \text{ N}$   $98^\circ$ , right picture:  $F = 54 \text{ N}$   $5^\circ$
20.  $4 \text{ m/s}^2$ ;  $22.5^\circ$  NE
22. 0.2
24. Yes, because his weight of 784 N is greater than what the rope can hold.
- 26a. While accelerating down
- 26c. 826 N
- 27b. 490 N
29. 3.6 kg
- 31b. 20 N
- 31d. 1.63 kg
- 32a. 1450 N
- 32c. 5700 N
- 32e. Fuel, engine, or equal and opposite reaction
- 33c. no, the box is flat so the normal force doesn't change
- 33e. 28 m/s
- 33g. 69 N
- 33i. 40 N
- 33k. 0.09
- 35b.  $-kx_0$
- 36c.  $Ma$
- 36e. Solve by using  $d = 1/2at^2$  and substituting  $h$  for  $d$
- 37b. Yes,  $T_A$  and the angle gives you  $m_1$  and the angle and  $T_C$  gives you  $m_2$ ,  $m_1 = T_A \cos 25^\circ / g$  and  $m_2 = T_C \cos 30^\circ / g$
- 38d. 90 m

## Ch 6: Centripetal Forces

- 5a. 100 N
- 5b.  $10 \text{ m/s}^2$
- 6a. 25 N towards her
- 6b. 25 N towards you

- 7a.  $14.2 \text{ m/s}^2$   
 7b.  $7.1 \times 10^3 \text{ N}$   
 8.  $.0034g$   
 9b. The same as a.  
 11.  $4.2 \times 10^{-7} \text{ N}$ ; very small force
- 13a.  $4 \times 10^{26} \text{ N}$   
 13c.  $2 \times 10^{41} \text{ kg}$   
 15a.  $.765$   
 16a.  $\sim 10^{-8} \text{ N}$  very small force
- 17a.  $4.23 \times 10^7 \text{ m}$   
 17d. The same, the radius is independent of mass  
 19. You get two answers for  $r$ , one is outside of the two stars one is between them, that's the one you want,  $1.32 \times 10^{10} \text{ m}$  from the larger star.  
 22b.  $v$ -down,  $a$ -right  
 22d. Yes,  $640 \text{ N}$
- 7c. friction between the tires and the road  
 9a.  $6.2 \times 10^5 \text{ m/s}^2$   
 10.  $3.56 \times 10^{22} \text{ N}$   
 12.  $g = 9.8 \text{ m/s}^2$ ; you'll get close to this number but not exactly due to some other small effects  
 13b. gravity  
 14.  $.006 \text{ m/s}^2$   
 15b.  $4880 \text{ N}$   
 16b. Your pencil does not accelerate toward you because the frictional force on your pencil is much greater than this force.  
 17b.  $6.6 R_e$   
 18.  $1.9 \times 10^7 \text{ m}$   
 22a.  $v = 28 \text{ m/s}$   
 22c.  $f$ -right

### Ch 7: Momentum Conservation

8.  $37.5 \text{ m/s}$   
 10a. 24  
 $\frac{kg \cdot m}{s}$   
 10c. 22  
 $\frac{kg \cdot m}{s}$
- 10e.  $109 \text{ N}$  due to Newton's third law  
 12.  $21 \text{ m/s}$  to the left  
 14a. 90 sec  
 15a.  $60 \text{ m/s}$   
 15c. yes,  $8.16 \text{ m}$   
 17a.  $11000 \text{ N}$  to the left  
 17c.  $2500 \text{ lb.}$   
 18a. no change  
 19a.  $0.00912 \text{ s}$   
 20a.  $0.0058 \text{ m/s}^2$
9.  $v_1 = 2v_2$   
 10b.  $0.364 \text{ m/s}$   
 10d.  $109 \text{ N}$   
 11.  $2.0 \text{ kg}$ ,  $125 \text{ m/s}$   
 13.  $3250 \text{ N}$   
 14b.  $1.7 \times 10^5 \text{ sec}$   
 15b.  $.700 \text{ sec}$   
 16.  $0.13 \text{ m/s}$  to the left  
 17b. tree experienced same average force of  $11000 \text{ N}$  but to the right  
 17d. about  $2.5 \text{ "g"}$ s of acceleration  
 18b. the last two cars  
 20b.  $3.5 \text{ m/s}^2$

21a. 15 m/s

21b.  $49^\circ$  S of E

22b. 4.6 m/s  $68^\circ$

### Ch 8: Energy & Force

6a.  $7.18 \times 10^9$  J

6b. 204 m/s

7a. 34 m/s @ B; 28 m/s @ D; 40 m/s @ E; 49 m/s @ C and F; 0 m/s @ H

7b. 30 m

7c. Yes, it makes the loop

8a. 2.3 m/s

8c. No, the baby will not clear the hill.

9a. 29,500 J

9b. 7.9 m

11a. 86 m

11b. 220 m

12a. 48.5 m/s

12b. 128 N

13. 0.32 m/s each

14a. 10 m/s

14b. 52 m

15a.  $1.1 \times 10^4$  N/m

15b. 2 m above the spring

16. 96%

18a. .008 m

18b.  $5.12^\circ$

19. 8 m/s same direction as the cue ball and 0 m/s

20.  $v_{\text{golf}} = -24.5$  m/s;  $v_{\text{pool}} = 17.6$  m/s

21. 2.8 m

22a. 0.57 m/s

22b. Leonora's

22c. 617 J

23a. 19.8 m/s

23b. 8.8 m/s

23c. 39.5 m

24a. 89 kW

24b. 0.4

24c. 15.1 m/s

25. 43.8 m/s

29a.  $3.15 \times 10^5$  J

29b. 18.0 m/s

29c. 2.41 m

29d. 7900 J

30a.  $v_0 / 14$

30b.  $mv_0^2 / 8$

30c.  $7mv_0^2 / 392$

30d. 71%

### Ch 9: Rotational Motion

2a.  $9.74 \times 10^{37}$  kg m<sup>2</sup>

2b.  $1.33 \times 10^{47}$  kg m<sup>2</sup>

2c. 0.5 kg m<sup>2</sup>

2d. 0.28 kg m<sup>2</sup>

2e. 0.07 kg m<sup>2</sup>

3a. True, all rotate  $2\pi$  for 86,400 sec which is 24 hours,

3b. True,  $\omega = 2\pi/t$  and  $t=86,400$  s

3f. True, L is the same

3g.  $L = I\omega$  and  $I = 2/5 mr^2$

3h. True,  $K = \frac{1}{2} I\omega^2$  &  $I = 2/5 mr^2$  sub-in  $K = \frac{1}{5} mr^2\omega^2$

3i. True,  $K = \frac{1}{2} I\omega^2$  &  $I = mr^2$  sub-in  $K = \frac{1}{2} mr^2\omega^2$

4a. 250 rad

4b. 40 rad

4c. 25 rad/s

4d. Force applied perpendicular to radius allows  $\alpha$

4e. 0.27 kg m<sup>2</sup>,

- 4f.  $K^5 = 84 \text{ J}$  and  $K^{10} = 340 \text{ J}$
8. Lower
- 10a. 200 N team
- 10c.  $0.02 \text{ rad/s}^2$
- 11a. Coin with the hole
- 12a. weight
- 12c. plank's length (0.8m) left of the pivot
- 12e. Ba. weight, Bb. 14.7 N, Bc. plank's length (0.3m) left of the pivot, Bd. 4.4 N m, Ca. weight, Cb. 13.6 N, Cc. plank's length (1.00 m) right of the pivot, Cd. 13.6 N m, f) 6.5 N m CC, g) no, net torque doesn't equal zero
- 13b. 7.27 Hz
- 14b.  $1.25 \times 10^5 \text{ J}$
- 14d. 12,500 m-N
16. 2300 N
- 17c.  $554 \text{ kgm}^2$
- 18a. 300 N
- 18c. .092
- 19b. 856 n toward beam, 106 N down
- 19d.  $3.39 \text{ rad/sec}^2$
- 20b. CCW
- 21c. 17410 N
6. Moment of inertia at the end  $\frac{1}{3} ML^2$  at the center  $\frac{1}{12} ML^2$ , angular momentum,  $L = I\omega$  and torque,  $\tau = I\alpha$  change the in the same way
9. Iron ball
- 10b. 40 N
- 10d. 25 s
- 11b. Coin with the hole
- 12b. 19.6 N
- 12d. 15.7 N m,
- 13a.  $7.27 \times 10^{-6} \text{ Hz}$
- 14a. 100 Hz
- 14c. 2500 J-s
15. 28 rev/sec
- 17b. 771 N, 1030 N
- 17d.  $4.81 \text{ rad/sec}^2$
- 18b. 240N, -22 N
- 19a. 2280 N
- 19c.  $425 \text{ kgm}^2$
- 20a. -1.28 Nm
- 21a. 1411 kg
- 21d. angular acc goes down as arm moves to vertical

### Ch 10: Simple Harmonic Motion

- 1a. Buoyant force and gravity
- 2a.  $9.8 \times 10^5 \text{ N/m}$
- 2c. 22 Hz, no,
- 4a. 110 N/m
- 7a. 0.0038 s
10. 4 times
- 12a. 16 Hz
- 12c. 0.063 s
- 13b. 11.1m/s, 0, 0
- 13d. .169 sec, 5.9 Hz
- 14c. 1.40m/s
- 14f. 2.82 N
- 1b.  $T = 6 \text{ s}$ ,  $f = 1/6 \text{ Hz}$
- 2b. 0.5 mm
3.  $3.2 \times 10^3 \text{ N/m}$
- 4d.  $v(t) = (25)\cos(83t)$
- 7b. 0.0038 s
11. 0.04 m
- 12b. 16 complete cycles but 32 times up and down, 315 complete cycles but 630 times up and down
- 13a. 24.8 J, 165 N,  $413 \text{ m/s}^2$
- 13c. 6.2 J, 18.6 J, 9.49 m/s,  $82.5 \text{ N}$ ,  $206 \text{ m/s}^2$
- 14b. .245 J
- 14d. 1.00 m/s
- 14g. 3.10 N

### Ch 11: Wave Motion and Sound

1. 390 Hz
- 2b. It was being driven near its resonant frequency.
- 2d. (Note that earthquakes rarely shake at more than 6 Hz).
- 5b. 3.6 Hz
- 7a. 1.7 cm
- 8a.  $4.3 \times 10^{14}$  Hz
- 9a. 2.828 m
- 9c.  $L = \frac{1}{4} \lambda$  so it would be difficult to receive the longer wavelengths.
- 11b. Same as closed at both ends
14. 0.53 m
16. 430 Hz;  $1.3 \times 10^3$  Hz;  $2.1 \times 10^3$  Hz;  $3.0 \times 10^3$  Hz;
- 17b. If the temperature increases the wavelength will not change, but the frequency will increase accordingly.
19. 80 Hz; 0.6 m
- 20b. 0.914 m
21. 2230 Hz; 2780 Hz; 2970 Hz
23. 150 m/s
- 2a. 4 Hz
- 2c. 8 Hz, 12 Hz
- 5a. 7 nodes including the 2 at the ends
6. 1.7 km
- 7b. 17 m
- 8b.  $2.3 \times 10^{-15}$  s - man that electron is moving fast
- 9b. 3.352 m
10. Very low frequency
13. 1.9 Hz or 2.1 Hz.
15. 2.2 m, 36 Hz; 1.1 m, 73 Hz; 0.733 m, 110 Hz; 0.55 m, 146 Hz
- 17a. The tube closed at one end will have a longer fundamental wavelength and a lower frequency.
18. struck by bullet first .
- 20a. 0.457 m
- 20c. 1.37 m
22. 498 Hz

## Ch 12: Electricity

- 11b. 1350 N
- 12a.  $1.1 \times 10^9$  N/C
13.  $F_g = 1.0 \times 10^{-47}$  N and  $F_e = 2.3 \times 10^{-8}$  N. The electric force is 39 orders of magnitudes bigger.
- 16a. down
- 16e.  $2.9 \times 10^8$  m/s<sup>2</sup>
- 17b.  $3.6 \times 10^4$  N/C to the left with a force of  $2.8 \times 10^{-7}$  N
19. 0.293 N and at 42.5°
- 21a. 7500V
- 22a.  $6.4 \times 10^{-17}$  N
- 22c.  $2.1 \times 10^{-16}$  J
- 23b. 0.25m
- 23d. 0.37  $\mu$ C
- 11c. 1350 N
- 12b. 9000 N
14.  $1.0 \times 10^{-4}$  C
- 16b. Up 16c,  $5.5 \times 10^{11}$  m/s<sup>2</sup>
- 17a. Toward the object
18. Twice as close to the smaller charge, so 2 m from 12 $\mu$ C charge and 1 m from 3 $\mu$ C charge.
20. 624 N/C and at an angle of -22.4° from the + x-axis.
- 21b. 1.5 m/s
- 22b. 1300V
- 22d.  $2.2 \times 10^7$  m/s
- 23c.  $F_T = 0.022$  N

## Ch 13: Electric Circuits – Batteries and Resistors

- 1a. 4.5C  
 2a. 0.11 A  
 2c.  $2.5 \times 10^{21}$  electrons  
 3a. 192  $\Omega$   
 4a. 5.4 mV  
 4c.  $7.3 \times 10^{-11}$  W, not a lot  
 5. left = brighter, right = longer  
 6b. 448 W  
 7b. 8.3 W  
 10. 0.8A and the 50  $\Omega$  on the left  
 11b. 112 W  
 11d. 0.94 A  
 11f. both 50  $\Omega$  resistors are brightest, then 45  $\Omega$ , then 75  $\Omega$  |  
 12a. 0.76 A  
 13b. 1000 W  
 15b. 29.1  $\Omega$   
 15d. 26.8  $\Omega$   
 15f. 21.5V  
 15h. 6.1V  
 15j. 16 kW  
 16b. 0.36A  
 23a. 10V
- 1b.  $2.8 \times 10^{19}$  electrons  
 2b. 1.0 W  
 2d. 3636 W  
 3b. 0.42 W  
 4b.  $1.4 \times 10^{-8}$  A  
 4d.  $2.6 \times 10^{-7}$  J  
 6a. 224 V  
 6c. 400 W by 100  $\Omega$  and 48 W by 12  $\Omega$   
 8. 0.5A  
 11a. 0.94 A  
 11c. 0.35 A  
 11e. 50, 45, 75  $\Omega$   
 12b. 7.0 W  
 15a. 9.1  $\Omega$   
 15c. 10.8  $\Omega$   
 15e. 1.8A  
 15g. 19.4V  
 15i. 0.24A  
 16a. 3.66  $\Omega$   
 16c. 1.32 V

#### Ch 14: Magnetism

1. No: if  $v = 0$  then  $F = 0$ ; yes:  $F = qE$   
 4b. Down the page  
 5. Both pointing away from north  
 9. Down the page; 60 N  
 10b. 91.7 m/s  
 11. East  $1.5 \times 10^4$  A  
 13.  $1.2 \times 10^5$  V, counterclockwise  
 14b. Counter-clockwise  
 15b. Into the page  
 15d. CW  
 16b.  $9.69 \times 10^{-12}$  N  
 17. E/B  
 18b.  $1.3 \times 10^{-6}$  C  
 19b. CCW  
 19d. .16 N/C  
 20a.  $1.11 \times 10^8$  m/s  
 20d. .00364 T
- 4a. Into the page  
 4c. Right  
 8. 7.6 T, north  
 10a. To the right,  $1.88 \times 10^4$  N  
 10c. It should be doubled  
 12. 0.00016 T; if CCW motion, B is pointed into the ground.  
 14a. 15 V  
 15a.  $2 \times 10^{-5}$  T  
 15c. 2.8 N/m  
 16a.  $2.42 \times 10^8$  m/s  
 16c. .0055 m  
 18a.  $8 \times 10^{-7}$  T  
 19a. 0.8 V  
 19c. .064 N  
 19e. .13 w  
 20b.  $9.1 \times 10^{-30}$  N  $\ll$   $6.4 \times 10^{-14}$  N  
 20e. .173 m



20f.  $7.03 \times 10^{16} \text{ m/s}^2$

21.  $19.2 \text{ V}$

22b.  $2.68 \times 10^{-13} \text{ N, -y}$

22d.  $.00838 \text{ m}$

22f.  $16,800 \text{ V}$

23b.  $1.5 \times 10^{-17} \text{ N, -y}$

20g.  $3.27^\circ$

22a.  $8.39 \times 10^7 \text{ m/s}$

22c.  $2.95 \times 10^{17} \text{ m/s}^2$

22e.  $1.68 \times 10^6 \text{ N/C}$

23a.  $1.2 \times 10^{-6} \text{ T, +z}$

23c.  $96 \text{ N/C, -y}$

### ch 15: Electric Circuits—Capacitors

2a.  $4 \times 10^7 \text{ V}$

4a.  $100 \text{ V}$

5.  $21 \text{ V}$ , V is squared so it doesn't act like problem 4

6b.  $54 \Omega$

7b.  $5 \times 10^{-9} \text{ F}$

8a.  $6 \text{ V}$

8c.  $18 \text{ V}$

8e.  $3.2 \times 10^{-3} \text{ J}$

9a.  $26.7 \mu\text{F}$

10a.  $19.0 \times 10^3 \text{ N/C}$

10c.  $1.6 \times 10^{15} \text{ m/s}^2$

10e.  $8.9 \times 10^{-7} \text{ m}$

2b.  $4 \times 10^9 \text{ J}$

4b. A greater voltage created a stronger electric field, or because as charges build up they repel each other from the plate.

6a.  $3.3 \text{ F}$

7a.  $200 \text{ V}$

7c.  $2.5 \times 10^{-9} \text{ F}$

8b.  $0.3 \text{ A}$

8d.  $3.6 \times 10^{-4} \text{ C}$

8f. i)  $80 \mu\text{F}$  ii)  $40 \mu\text{F}$  iii)  $120 \mu\text{F}$

9b.  $166.7 \mu\text{F}$

10b.  $1.4 \times 10^{-15} \text{ N}$

10d.  $3.3 \times 10^{-11} \text{ s}$

10f.  $5.1 \times 10^{-30}$

### Ch 16: Electric Circuits—Advanced

1a.  $4.9 \times 10^{-5} \text{ H}$

2. Zero

3b. No

4a.  $0.5 \text{ V}$

4c.  $0.05 \text{ A}$

4e.  $8.25 \text{ V}$

5a. On

5c. On, on, off, on, off, off, on, on

6c.  $195 \Omega$

6e.  $1.39 \text{ A}$

6g.  $115 \text{ Hz}$

1b.  $-9.8 \times 10^{-5} \text{ V}$

3a. Yes

3c. Because they turn current flow on and off.

4b.  $0.05 \text{ A}$

4d.  $5.5 \text{ V}$

4f.  $11 \times$

5b. On

6b.  $10.9 \mu\text{F}$

6d.  $169 \Omega$

6f.  $-42^\circ$

### Ch 17: Light

3. 2200 blue wavelengths

5.  $6 \times 10^{14} \text{ Hz}$

4. 65000 x-rays

5. 6. 3.3 m

- 8b. vacuum & air
9.  $6.99 \times 10^{-7}$  m;  $5.26 \times 10^{-7}$  m
13.  $25^\circ$
- 16a.  $49.7^\circ$
- 16c.  $48.8^\circ$
- 17c. 11.5 m
- 19c. +4 units
- 20a. 6 units
- 21c. 1.5 units
- 22c. 3 units
- 23c. 5.3 units
27. 32 cm
- 28b. 27 cm
- 29a. 0.72 m
33.  $13.5^\circ$
- 8c.  $1.96 \times 10^8$  m/s
12. Absorbs red and green.
15.  $33.3^\circ$
- 16b. No such angle
- 17b. 11.4 m
18. 85 cm
- 19e. -1
- 20b. bigger;  $M = 3$
- 21d.  $2/3$
- 22e.  $-2/3$
- 25b. 22.5 mm
- 28a.  $10.2^\circ$
- 28c. 20 cm
31. 54 cm, 44cm, 21 cm, 8.8 cm
34. 549 nm

### Ch 18: Fluids

1. 0.84
- 3a. 90% of the berg is underwater
- 4b.  $5.06 \times 10^{-4}$  N
5. 4.14 m/s
- 7b. upward
- 7d. Cooler air outside, so more initial buoyant force
- 8a. At a depth of 10 cm, the buoyant force is 2.9 N
- 9a. 83,000 Pa
- 9c. 110 N
- 10b. 591 kPa
12. .0081
- 13b. 849 kPa
- 13d. 12.0 kW
- 13f. \$210,000
- 14b. 6 atm
- 16a.  $27 \text{ m/s}^2$ , (2.7 g) upward
- 16c. 2200 N
- 17b. 10.5 N
- 17d. 11 N
- 18b. 2.0 m (note: here and below, you may choose differently)
- 18e. 3.5 million N
2.  $1.4 \times 10^5$  kg
- 3b. 57%
- 4c.  $7.05 \text{ m/s}^2$
6. 40 coins
- 7c.  $4.5 \text{ m/s}^2$
- 7e. Thin air at high altitudes weighs almost nothing, so little weight displaced.
- 8d. The bottom of the cup is 3 cm in radius
- 9b. 104 N
- 10a. 248 kPa
- 10c. 1081 kPa
- 13a.  $12500 \text{ J/m}^3$
- 13c. 5.33 kW
- 13e. 54 A
- 14a. 611 kPa
- 15b. 500,000 N
- 16b. 1600 N
- 17a. 10 N
- 17c. 11 N
- 18a. "The Thunder Road"
- 18c.  $33.5 \text{ m}^3$
- 18f. 111 MPa

### Ch 19: Thermodynamics and Heat Engines

18. 517 m/s  
 21. 40 N  
 23a. 21,000 Pa  
 23c. 5.8 km  
 24b. allowed by highly improbable state. More likely states are more disordered.  
 25b.  $6.64 \times 10^{-27}$  kg  
 25d. 744 kPa  
 25g.  $0.00785 \text{ m}^3$   
 26b. 0.56 MW  
 27a. 54%  
 27c. 890 kW  
 27e. 630 kg  
 28b. 4.0%  
 29. 14800 J  
 31b. 720 K, 300 K, 600 K  
 31d. C to A; B-C  
 32b. 300 K, 1200 K  
 33b. -120 J  
 33d. 35 J
19.  $1.15 \times 10^{12}$  K  
 22.  $\approx 10^{28}$  molecules  
 23b. Decreases to 61,000 Pa  
 24a. No  
 25a.  $8.34 \times 10^{23}$   
 25c. 1600 m/s  
 25e.  $4.2 \times 10^{20}$  or 0.0007 moles  
 26a. 1.9 MW  
 26c. 1.3 Mw  
 27b. 240 kW  
 27d. 590 kW  
 28a. 98%  
 28c. 12%  
 30. 12,000 J  
 31c. isochoric; isobaric  
 31e. 0.018 J  
 33a. 1753 J  
 33c. 80 J  
 33e. -100 J, 80 J, 80 J

## Ch 20: Special and General Relativity

1. longer  
 3. 76.4 m, 76.4 m  
 6.  $9.15 \times 10^7$  m/s  
 8a. 0.659 km  
 8c.  $4.92 \times 10^{-5}$  m/s  
 9. 2900 m  
 11. 0.303 s  
 13a. f  
 14.  $4.5 \times 10^{16}$  J;  $1.8 \times 10^{13}$  softballs  
 15b.  $3.04 \times 10^6$  J
2.  $\gamma = \infty$ , the universe would be a dot  
 5.  $\gamma = 1.002$   
 7.  $2.6 \times 10^8$  m/s  
 8b. 22.4  
 8d. 14.7 km  
 10.  $1.34 \times 10^{-57}$  m  
 12.  $2.9 \times 10^{-30}$  kg, yes harder to accelerate  
 13b. c  
 15a.  $1.568 \times 10^{-13}$  J

## Ch 21: Radioactivity and Nuclear Physics

- 6a. Substance A decays faster than B  
 6b. Substance B because there is more material left to decay.  
 7a.  ${}_{88}^{219}\text{Ra} \rightarrow {}_{86}^{215}\text{Rn} + {}_2^4\text{He}$   
 7b.  ${}_{63}^{158}\text{Eu} \rightarrow {}_{64}^{158}\text{Gd} + {}_{-1}^0\text{e}^-$   
 7c.  ${}_{22}^{53}\text{Ti} \rightarrow {}_{23}^{53}\text{V} + {}_{-1}^0\text{e}^-$   
 7d.  ${}_{83}^{211}\text{Bi} \rightarrow {}_{81}^{207}\text{Tl} + {}_2^4\text{He}$   
 8a.  $5 \times 10^{24}$  atoms  
 8b. Decay of a lot of atoms in a short period of time  
 8c.  $2.5 \times 10^{24}$  atoms  
 8d.  $\frac{1}{2}$

- 8e. 26.6 minutes
- 10a. Substance B = 4.6 g and substance A = 0.035 g
11. 1.2 g
13. 0.46 minutes
15. 0.0155 g
17. 49,000 years
9. The one with the short half life, because half life is the rate of decay.
- 10b. substance B
12. 125 g
14.  $t = 144,700$  years
16. 17 years

## Ch 22: Standard Model of Particle Physics

1. strange
3. Electron, photon, tau...
5. Neutron, because it doesn't have electrical charge
7. Two anti-up quarks and an anti-down quark
9. Yes,  $W^+$ ,  $W^-$ , because they both have charge
11. Yes; a,b,c,e; no; d,f
2. some type of meson
4. Neutron, electron neutrino,  $Z^0$
6. No, because it doesn't have electrical charge
8. Lepton number, and energy/mass conservation
10. The weak force because it can interact with both quarks and leptons
12. The standard model makes verifiable predictions, string theory makes few verifiable predictions.

## Ch 23: Feynman Diagrams

1. Allowed: an electron and anti-electron(positron) annihilate to a photon then become an electron and anti-electron(positron) again.
3. Not allowed: lepton number is not conserved
- 4b. Not allowed: neutrinos do not have charge and therefore cannot exchange a photon.
- 5b. Not allowed: lepton number not conserved
7. Allowed: electron neutrino annihilates with a positron becomes a  $W^+$  then splits to muon and muon neutrino.
9. Not allowed: charge not conserved
11. Not allowed: electrons don't interact with gluons
13. Allowed: the electron and the positron are exchanging virtual electron/positron pairs
15. Allowed: a muon splits into an muon neutrino, an electron and an electron neutrino via a  $W^-$  particle.
2. Not allowed: electrons don't go backward through time, and charge is not conserved
- 4a. Allowed: two electrons exchange a photon
- 5a. Allowed: an electron and an up quark exchange a photon
6. Not allowed: quark number not conserved
8. Allowed: up quark annihilates with anti-up quark becomes  $Z^0$ , then becomes a strange quark and anti-strange quark
10. Allowed: this is a very rare interaction
12. Not allowed: neutrinos don't interact with photons
14. Allowed: this is beta decay, a down quark splits into an up quark an electron and an electron neutrino via a  $W^-$  particle.

## Ch 24: Quantum Mechanics

- 1a.  $6.752 \times 10^{-26}$  J,  $2.253 \times 10^{-34}$  kgm/s  
 1c.  $4.90 \times 10^{-28}$  J,  $1.63 \times 10^{-36}$  kgm/s  
 2b. 12.7 ev,  $6.76 \times 10^{-27}$  kgm/s  
 3a. .0827 nm  
 3c. .942 nm  
 5a. 36 nm  
 5c. 380 nm, 73 nm, 36 nm, 92 nm, 39 nm  
 7. .564 nm  
 8b. .00120 nm  
 10.  $1.84 \times 10^8$  m/s  
 11b.  $3.14 \times 10^7$  J  
 11d. 1.55 pm  
 14b. 15  
 15. -10.3 ev, -3.82 ev, -2.29 ev, -1.83 ev  
 16b.  $1.70 \times 10^{-11}$  m  
 16d. .068 m  
 17b. 1.60 A  
 18a.  $4.40 \times 10^{-24}$  kgm/s  
 18c.  $3.23 \times 10^{-24}$  kgm/s  
 19a.  $1.1365 \times 10^{-22}$  kgm/s  
 19c.  $^{242}\text{Cu} \rightarrow ^4\text{He} + ^{238}\text{Pu}$   
 19e. 17.7 cm  
 19g. +y, 34.2 N/C
- 1b.  $5.96 \times 10^{-20}$  J,  $1.99 \times 10^{-28}$  kgm/s  
 2a. 1.94 ev,  $1.04 \times 10^{-27}$  kgm/s  
 2c. 5.00 ev,  $2.67 \times 10^{-21}$  kgm/s  
 3b.  $4.59 \times 10^{-4}$  nm  
 4.  $1.03 \times 10^{-20}$  m  
 5b. no  
 6. .80 V  
 8a. .124 nm  
 9. 24,600 m/s  
 11a. .491 m/s  
 11c. 64 Mw  
 12. 3.27 ev  
 14c. 182 nm, 188 nm, 206 nm, 230 nm  
 16a.  $4.19 \times 10^7$  m/s  
 16c.  $1.95^\circ$   
 17a. 1.89 V  
 17c. 1.25  $\Omega$   
 18b.  $1.17 \times 10^{-24}$  kgm/s  
 18d.  $3.76 \times 10^7$  m/s  
 19b. 5.860 pm  
 19d. 238.0497 amu  
 19f. -y

### Ch 25: Using Calculus to Solve Problems in Mechanics

- 1a. 8 m  
 1c.  $40 \text{ m/s}^2$   
 3a. 3.4 m/s  
 3c.  $F(t) = 3.6t - .4$   
 3e. 11.56 J  
 3g. 10.3 J  
 4c. 2000 kg  
 9a.  $k_1/2x^2 + k_2/3 x^3$
- 1b. -5 m/s  
 1d. 0  
 3b.  $a(t) = 1.8t - .2$   
 3d. .04 J  
 3f. 11.52 J  
 3h.  $P(x) = (x^2 + 2x + 2) dx/dt$   
 4e. 1037 N<sub>s</sub>  
 9b.  $k_1x + k_2^2 - k_3 dx/dt = md^2x/dt^2$

### Ch 26: Global Warming

- 1a.  $5.1 \times 10^{14}$  W  
 1c.  $1.6 \times 10^{22}$  J  
 1e. About 2.3 million bombs
- 1b.  $1.8 \times 10^{15}$  kWh  
 1d.  $7.0 \times 10^{15}$  J

# 28. Equations and Fundamental Constants

AUTHOR: James H. Dann, Ph.D., James J. Dann SOURCE: The People's Physics Book LICENSE: CCSA

## Simple Harmonic Motion and Wave Motion

$$T = 1 / f \quad v = \lambda f$$

$$f_n = \frac{nv}{2L} \text{ nodes at both ends}$$

$$v_{\text{sound}} = 343 \text{ m/s (in air at 20 C)}$$

$$T_{\text{SP}} = 2\pi \sqrt{\frac{m}{k}} \quad T_P = 2\pi \sqrt{\frac{L}{g}}$$

$$f_n = \frac{nv}{4L} \text{ (n is odd) node at one end}$$

$$\text{A note: 440 Hz}$$

$$\text{C note: 524 Hz}$$

$$\text{D note: 588 Hz}$$

$$\text{E note: 660 Hz}$$

$$\text{G note: 784 Hz}$$

$$f_{\text{beat}} = |f_1 - f_2|$$

## Fluids and Thermodynamics

$$3/2 kT = \langle 1/2 mv^2 \rangle_{\text{avg}}$$

$$PV = NkT = nRT$$

$$k = 1.381 \times 10^{-23} \text{ J/K}$$

$$P = F / A$$

$$F_{\text{buoy}} = -(\rho_{\text{water}} V_{\text{displaced}})g$$

$$\rho_{\text{air}} = 1.29 \text{ kg/m}^3$$

$$P = P_0 + \rho gh$$

$$Q_{\text{in}} = W + \Delta U + Q_{\text{out}}$$

$$R = 8.315 \text{ J/mol-K}$$

$$\Delta P + \Delta(\rho gh) + \Delta(1/2 \rho v^2) = 0$$

$$W = P\Delta V$$

$$\rho_{\text{water}} = 1000 \text{ kg/m}^3$$

$$\Phi = \mathbf{A} \cdot \mathbf{v}$$

$$k = 1/2 \rho v^2; u = \rho gh$$

$$P_{\text{ATMOSPHERE}} = 101,000 \text{ N/M}^2$$

$$^{\circ}\text{C} = ^{\circ}\text{K} + 273.15$$

$$\eta = W/Q_{\text{in}}; \eta_{\text{Carnot}} = 1 - (T_{\text{low}} / T_{\text{high}})$$

$$N_{\text{avo}} = 6.022 \times 10^{23} \text{ mol}^{-1}$$

## Properties of Fundamental Particles

$$m_{\text{proton}} = 1.6726 \times 10^{-27} \text{ kg}$$

$$m_{\text{electron}} = 9.109 \times 10^{-31} \text{ kg}$$

$$m_{\text{neutron}} = 1.6749 \times 10^{-27} \text{ kg}$$

$$q_{\text{electron}} = -q_{\text{proton}} = -1.602 \times 10^{-19} \text{ C} \quad 1 \text{ amu} = 1.6605 \times 10^{-27} \text{ kg} = 931.5 \text{ Mev}/c^2$$

$$r_{\text{hydrogen atom}} \approx 0.529 \times 10^{-10} \text{ m}$$

$$\Delta E = \Delta mc^2$$

## Radioactivity, Nuclear Physics, and Quantum Mechanics

$$(\Delta x)(\Delta p) \approx h/4\pi$$

$$\lambda = h/p$$

$$N = N_0 (1/2)^{t/t_H}$$

$$1\text{eV} \rightarrow 1240\text{ nm}$$

(energy of a photon)

$$(\Delta E)(\Delta t) \approx h/4\pi$$

$$E_{\text{photon}} = hf = pc$$

$$K_{\text{max}} = qV = hf + \phi$$

$$h = 6.626 \times 10^{-34}\text{ J}\cdot\text{s}$$

$^A_Z$  = element Z with A nucleons

$^{14}\text{C}$ :  $t_H = 5,730$  years (half life =  $t_H$ )

$^{239}\text{Pu}$ :  $t_H = 24,119$  years

$E_0 = -13.605\text{ eV}$  (Hydrogen ground state)

## Light

$$\lambda_{\text{blue}} \approx 450\text{ nm}$$

$$\lambda_{\text{green}} \approx 500\text{ nm}$$

$$\lambda_{\text{red}} \approx 600\text{ nm}$$

$$n_i \sin(\theta_i) = n_r \sin(\theta_r)$$

$$c = 2.998 \times 10^8\text{ m/s}$$

$$m\lambda = d \sin(\theta)$$

$$n_{\text{air}} \approx n_{\text{vacuum}} = 1.00$$

$$n_{\text{water}} = 1.33$$

$$n = c/v_{\text{material}}$$

primary: Red, Green, Blue

secondary: Magenta, Cyan, Yellow

$$\frac{1}{f} = \frac{1}{d_o} + \frac{1}{d_i} \quad M = h_i/h_o = d_i/d_o$$

## Electricity and Magnetism

$$\mathbf{F}_E = k q_1 q_2 / r^2$$

$$\mathbf{E} = \mathbf{F}_E / q$$

$$\mathbf{E} = -\Delta V / \Delta x$$

$$\mathbf{F}_B = q\mathbf{v} \times \mathbf{B} = qvB \sin(\theta)$$

$$\mathbf{B}_{\text{wire}} = \mu_0 I / 2\pi r$$

$$\mathbf{F}_{\text{wire}} = \ell(\mathbf{I} \times \mathbf{B}) = \ell IB \sin(\theta)$$

(direction: RHR)

(direction: RHR)

(direction: RHR)

$$k = 8.992 \times 10^9\text{ N}\cdot\text{m}^2/\text{C}^2$$

$$\mu_0 = 4\pi \times 10^{-7}\text{ T}\cdot\text{m/A}$$

$$\Phi = BA \cos(\theta)$$

$$\frac{U_{e1}}{q\Delta V} = \frac{U_{e2}}{q\Delta V} \quad \text{for point charges only, } E(r) = kq/r^2 \text{ and } V(r) = kq/r \quad V = -\Delta\Phi / \Delta t = Blv$$

$$(k = 1/4\pi\epsilon_0 \text{ where } \epsilon_0 = 8.854 \times 10^{-12}\text{ C}^2/\text{N}\cdot\text{m}^2)$$

## Electric Circuits

$$\Delta V = IR$$

$$I = \Delta q / \Delta t = \Delta V / R$$

$$\tau = RC$$

$$P = \Delta E / \Delta t = I\Delta V = I^2 R = V^2 / R$$

$$R = \rho l / A$$

$$V = -L(\Delta I / \Delta t)$$

$$Q = C \Delta V$$

$$C_{\text{parallel plate}} = \kappa \epsilon A / d$$

$$C_{\text{parallel}} = C_1 + C_2 + \dots$$

$$R_{\text{series}} = R_1 + R_2 + \dots$$

$$1 / R_{\text{parallel}} = (1/R_1) + (1/R_2) + \dots$$

$$1 / C_{\text{series}} = (1/C_1) + (1/C_2) + \dots$$

Name	Symbols		Unit	Typical examples
Voltage Source	$\Delta V$		volt (V)	9 V (cell phone charger); 12 V (car); 120 VAC (U.S. wall outlet)
Resistor	<b>R</b>		Ohm ( $\Omega$ )	144 $\Omega$ (100 w, 120v bulb); 1 k $\Omega$ (wet skin)
Capacitor	<b>C</b>		Farad (F)	RAM in a computer, 700 MF (Earth)
Inductor	<b>L</b>		Henry (H)	7 H (guitar pickup)
Diode	by type		none	light-emitting diode (LED); solar panel
Transistor	by type		none	Computer processors

## Equation Sheet



### Mathematics

$$\sin(\theta) = b/c \rightarrow b = c \cdot \sin(\theta)$$

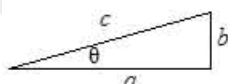

$$180^\circ = \pi \text{ radians}$$

$$\cos(\theta) = a/c \rightarrow a = c \cdot \cos(\theta)$$

$$C_{\text{circle}} = 2\pi R$$

$$\tan(\theta) = b/a \rightarrow b = a \cdot \tan(\theta)$$

$$A_{\text{circle}} = \pi R^2$$

$$c^2 = a^2 + b^2$$

$$V_{\text{sphere}} = (4/3)\pi R^3$$

$$V_{\text{cylinder}} = \pi R^2 h$$

If X is any unit, then...

$$1 \text{ mX} = 0.001 \text{ X} = 10^{-3} \text{ X}$$

$$1 \text{ kX} = 1 \text{ 000 X} = 10^3 \text{ X}$$

$$1 \text{ }\mu\text{X} = 0.000 \text{ 001 X} = 10^{-6} \text{ X}$$

$$1 \text{ MX} = 1 \text{ 000 000 X} = 10^6 \text{ X}$$

$$1 \text{ nX} = 0.000 \text{ 000 001 X} = 10^{-9} \text{ X}$$

$$1 \text{ GX} = 1 \text{ 000 000 000 X} = 10^9 \text{ X}$$



If  $ax^2 + bx + c = 0$ , then...

$$x = \frac{-b \pm \sqrt{b^2 - 4ac}}{2a}$$

$$\% \text{ difference} = |(\text{measured} - \text{accepted}) / \text{accepted}| \times 100\%$$

vector dot product:  $\mathbf{a} \cdot \mathbf{b} = ab \cos\theta$  (product is a scalar)--- $\theta$  is angle between vectors

vector cross product:  $\mathbf{a} \times \mathbf{b} = ab \sin\theta$  (direction is given by RHR)

### Kinematics Under Constant Acceleration

$$\Delta x = x_{\text{final}} - x_{\text{initial}}$$

$$x(t) = x_0 + v_0 t + \frac{1}{2} a_x t^2$$

$$g = 9.81 \text{ m/s}^2 \approx 10 \text{ m/s}^2$$

$$\Delta(\text{anything}) = \text{final value} - \text{initial value}$$

$$v(t) = v_0 + at$$

$$1 \text{ km} = 1000 \text{ m}$$

$$\mathbf{v}_{\text{avg}} = \Delta \mathbf{x} / \Delta t$$

$$v^2 = v_0^2 + 2a(\Delta x)$$

$$1 \text{ meter} = 3.28 \text{ ft}$$

$$\mathbf{a}_{\text{avg}} = \Delta \mathbf{v} / \Delta t$$

$$1 \text{ mile} = 1.61 \text{ km}$$

$$(x = x_0 \text{ and } v = v_0 \text{ at } t = 0)$$

### Newtonian Physics and Centripetal Motion

$$\mathbf{a} = \mathbf{F}_{\text{net}} / m \quad \mathbf{F}_g = mg$$

$$f_k = \mu_k F_N \quad \mathbf{F}_{\text{sp}} = -k(\Delta \mathbf{x})$$

$$G = 6.672 \times 10^{-11} \text{ N} \cdot \text{m}^2 / \text{kg}^2$$

$$\mathbf{F}_{\text{net}} = \Sigma \mathbf{F}_{\text{all individual forces}}$$

$$f_s \leq \mu_s F_N \quad \mathbf{F}_G = Gm_1 m_2 / r^2$$

$$1 \text{ kg} = 1000 \text{ g} = 2.2 \text{ lbs}$$

$$N = 1 \text{ kg} \cdot \text{m/s}^2$$

ma

$$F_c = mv^2 / r$$

### Momentum and Energy Conservation

$$\Sigma \mathbf{p}_{\text{initial}} = \Sigma \mathbf{p}_{\text{final}} \quad \mathbf{p} = m\mathbf{v}$$

$$\mathbf{F}_{\text{avg}} = \Delta \mathbf{p} / \Delta t$$

$$W = \mathbf{F} \cdot \Delta \mathbf{x}$$

$$1 \text{ J} = 1 \text{ N} \cdot \text{m}$$

$$E_{\text{initial}} = E_{\text{final}}$$

$$K = \frac{1}{2} mv^2$$

$$U_g = mgh$$

$$P = \Delta W / \Delta t$$

$$1 \text{ W} = 1 \text{ J/s}$$

$$E = K + U + W$$

$$U_{\text{sp}} = \frac{1}{2} k(\Delta x)^2$$

$$P = \mathbf{F} \cdot \mathbf{v}$$

$$1 \text{ food Calorie} = 4180 \text{ J}$$

$$1 \text{ eV} = 1.602 \times 10^{-19} \text{ J}$$

$$U_g = -Gm_1 m_2 / r$$

$$1 \text{ kWh} = 3.600 \times 10^6 \text{ J}$$

### Rotational Motion

$$d = r\theta$$

$$\theta(t) = \theta_0 + \omega_0 t + \frac{1}{2} \alpha t^2$$

$$K = \frac{1}{2} I \omega^2$$

$$I_{\text{ring about cm}} = MR^2$$

$$v = r\omega$$

$$\frac{1}{2} \alpha t^2$$

$$\mathbf{L} = \mathbf{r} \times \mathbf{p} = I\omega$$

$$I_{\text{disk about cm}} = \frac{1}{2} MR^2$$

$$a = r\alpha$$

$$\omega(t) = \omega_0 + \alpha t$$

$$\boldsymbol{\tau} = \mathbf{r} \times \mathbf{F} = \Delta \mathbf{L} / \Delta t$$

$$\omega = 2\pi / T$$

$$\omega^2 = \omega_0^2 + 2\alpha(\Delta\theta)$$

$$I_{\text{rod about end}} = (1/3)ML^2$$

$$a_c = -r\omega^2$$

$$I_{\text{solid sphere about cm}} = (2/5)MR^2$$

### *Astronomy*

$$P_{\odot} = 4 \times 10^{26} \text{ W}$$

$$1 \text{ light-year (ly)} = 9.45 \times 10^{15} \text{ m}$$

$$\text{Earth-Sun distance} = 1.496 \times 10^{11} \text{ m}$$

$$M_{\odot} = 1.99 \times 10^{30} \text{ kg}$$

$$M_{\text{Earth}} = 5.97 \times 10^{24} \text{ kg}$$

$$M_{\text{Moon}} = 7.35 \times 10^{22} \text{ kg}$$

$$R_{\odot} = 6.96 \times 10^8 \text{ m}$$

$$R_{\text{Earth}} = 6.38 \times 10^6 \text{ m}$$

$$R_{\text{Moon}} = 1.74 \times 10^6 \text{ m}$$

$$\text{Earth-Moon distance} = 3.84 \times 10^8 \text{ m}$$

DRAFT