

Torque Mastery Assignment

1. A mechanic has an idea for hanging a sign outside of his business. He wants to hang a 10,000 N car 3.0 meters from the building. The 200 kg beam he is using is 5 m long. The beam's center of gravity is 2.0 m from the building. The only cable he can find withstands a maximum tension of 15,000N, show that his plan to hang the car will either work or not work.

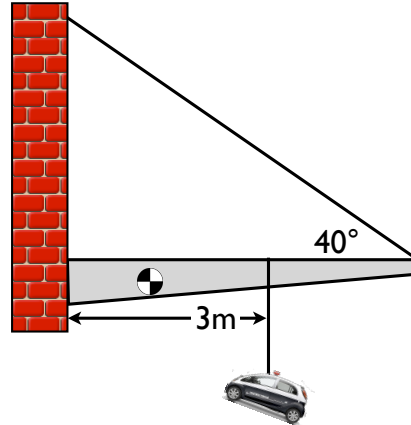

2. A 400 kg beam with a center of mass 1.5 m from the left is suspended between two walls by the two cables shown below. A box containing a gorilla is placed on the beam such that the center of gravity of the box is 1.0 m from the right end of the beam. **USING ONLY TORQUES**, find the tension in the left and right cables.

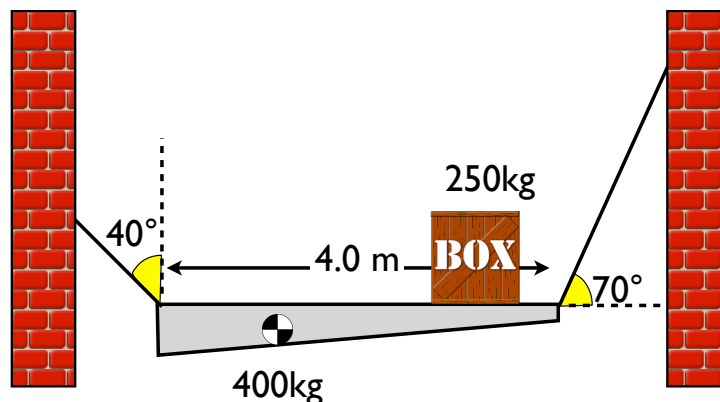

3. In a balancing act at the "Cirque du Soleil," an performer is to hold a uniform, 3 kg, beam up, over his head. 3 cats of various masses are sitting on the beam as shown below. The uniform beam is 1.5 m long. How far from the left end of the beam should the performer lift it up to keep it balanced?

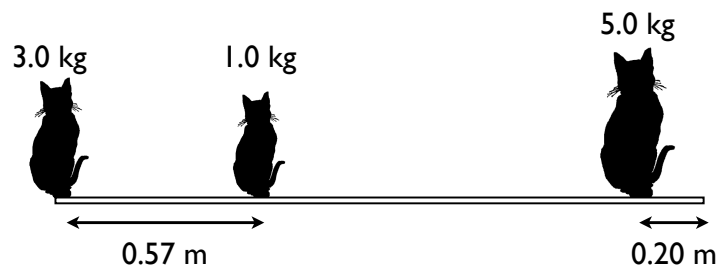

Torque Mastery Assignment

4. A Samauri sword is 1.3 m long. Think of the sword as two pieces, the handle and the blade. Combined they make the sword 1.3 m long. The handle is 35 cm long and has a center of gravity 10 cm from the left end of the handle. The handle has a mass of 1.5 kg. The blade makes up the rest of the sword's length and has a mass of 530 g. The blade's center of gravity is 35 cm above the end of the handle. When holding the Samauri sword, your two hands should be placed directly above and below the sword's balance point. Where, from the left end, should the Samauri place his two hands?



5. For the Christmas holiday, a store is planning on hanging some solid steel ornaments from a beam attached to a wall. Each ball has a mass of 1.0 kg. The beam has a mass of 1.5 kg and its center of gravity is 0.85 meters from the wall. Calculate the tension in the cable and the vertical and horizontal reaction forces at the wall.

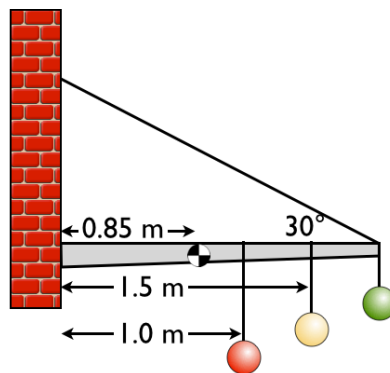

6. You and your friend have created a game where you place 5 gram nickles on the ruler that is hanging over the edge of a table. The 11 g ruler is 30 cm long and is uniform. 10 cm is placed over the edge of the table. If two nickles are placed as shown. What is the farthest distance away from the table's edge that a 3rd nickle can be placed without the rule tipping over? Only use torques to solve. (No cg formula.)

